

Engineering Plus

Planning – Surveying – Testing – Landscape Design

October 3, 2024

Carrie Barefoot
401/Stormwater Branch
Environmental Permits Division
MS Department of Environmental Quality, Office of Pollution Control
P.O. Box 2261
Jackson, MS 39225

**RE: *Tri-State Truck Center – Meridian, MS
Large Construction Notice of Intent Package***

Dear Ms. Barefoot:

Century Construction is preparing to develop a new Tri-State Truck Center in Meridian and will be performing clearing, grubbing and rough grading as part of their initial construction. This project brings another new development to the Meridian area. As stated above, this Notice of Intent is for clearing and grubbing and rough grading operations only. However, we do not anticipate any major modifications to the permit once detailed grading operations begin when it comes to the controls required on-site. Prior to any ground disturbing activities, such as clearing and grubbing, we are requesting permit coverage from your office.

Please find enclosed, for your review, a Stormwater Pollution Prevention Plan that includes a Large Construction General Permit Package with required applicant signatures. The package also includes other pertinent information for your review.

Thank you for your consideration in this matter. Please contact us if you have any questions or need additional information for this application.

Respectfully,



Richmond L. Alexander, P.E.
President

Enclosures: As noted

Storm Water Pollution Prevention Plan

**Tri-State Truck Center
Meridian, Mississippi**

**Prepared For:
Century Construction
Tupelo, Mississippi**

**Prepared By:
Engineering Plus, Inc.
1724-B 23rd Avenue
Meridian, MS 39301**

October 2024

TABLE OF CONTENTS

Introduction	2
Site Description	2
General Requirements	3
Best Management Practices	3
Housekeeping Practices	4
Implementation Sequence	4
Post Construction/Storm Water Management Measures	4
Inspection/Maintenance	5
Staff Training Requirements	5
MDEQ Large Construction Notice of Intent & General Permit Package	
City of Meridian Will Serve Letter	
Approved MDOT Grading Permit	
Best Management Standards	
Site Location Map	
Quad Map	
Soil Survey of Lauderdale County, MS	
Erosion Control Plan	

INTRODUCTION

This document is the Storm Water Pollution Prevention Plan (SWPPP) for proposed site clearing, grubbing and rough grading on a parcel of land at the northwest quadrant of the intersection of Jimmie Rodgers Parkway and Interstate 20/59 in Meridian, Mississippi. This plan is the criteria for compliance with the regulation set by the Environmental Protection Agencies National Pollutant Discharge Elimination System permit application regulations for storm water discharges regarding construction storm water. The purpose of the Storm Water Pollution Prevention Plan is for the control and mitigation of pollution in storm water discharges associated with the proposed project.

SITE DESCRIPTION

This project consists of clearing, grubbing and rough grading at the proposed site. This proposed construction will prepare the site for future fine grading operations and construction of a new Tri-State Truck Center adjacent to Interstate 20/59 in Meridian. Topsoil should be stockpiled and used to re-vegetate areas after grading operations to help establish vegetation of freshly disturbed soil. Best management practices shall be put in-place as shown on the attached Erosion Control Plan. Upon completion of grading activities, the disturbed areas will be permanently vegetated unless construction is to continue in those areas. Given the current topography and discharge points from the site, two (2) temporary/permanent detention basins are planned as part of this clearing, grubbing and rough grading phase.

Construction activities will disturb approximately 17 acres located in the northeast quarter of Section 9, Township 6 North, Range 16 East, Lauderdale County, Mississippi. The topography of the site contains both gently sloping areas as well as hilly areas with the majority of the drainage generally flowing to the northwest. Currently, surface runoff generally drains to the west and northwest toward Sowashee Creek. From the Soil Survey of Lauderdale County, by the Soil Conservation Service, the majority of the existing soils appear to be Sweatman Fine Sandy Loam (SmB2, SmE2,) soils.

The project site described above is currently an open area that has had the timber recently removed. The property is not currently being used for any industrial, commercial, agricultural, or residential purposes at this time. As stated above, storm water from this proposed site drains to the northwest and eventually flows to Sowashee Creek. Sowashee Creek is listed on the 303(d) list for impairment as prescribed by MDEQ. The impairment listed for Sowashee Creek is Total Nitrogen and Total Phosphorus. The impairment listed for Sowashee is shown miles downstream of the project site and extends to its confluence with Okatibbee Creek. Additionally, Sowashee Creek is shown as having two (2) TMDL's. One TMDL is for Organic Enrichment/Low DO while the other TMDL is for sediment. The controls utilized on-site, as shown in the Erosion Control Plan are sufficient to provide protection from impacting downstream to Sowashee Creek. These controls utilized on-site consists of silt fence, wattles, construction entrances and detention basins. Additional controls are not warranted due to the TMDL's associated with the receiving stream.

GENERAL REQUIREMENTS

The Storm Water Pollution Prevention Plan consists of various controls appropriate for this particular site. The purposes of these various controls shall:

- Implement Best Management Practices to reduce adverse effects from storm water runoff.
- Preserve existing vegetation and re-vegetating disturbed soil as soon as possible to limit the exposure time for the disturbed area.
- Remove sediment from storm water before it leaves the site through the use of structural controls.
- Minimize disturbed surface area.
- Prevent sediment from leaving the site by providing construction Best Management Practices throughout the entirety of the project.

BEST MANAGEMENT PRACTICES

The implementation of these practices is anticipated to begin in November 2024 and end July 2025. The controls of importance include but are not limited to:

- Installation of construction entrance/exit (see Erosion Control Plan).
- Installation of silt fencing and wattles as needed (see Erosion Control Plan).
- Installation of brush barriers if needed.
- Construction of temporary diversion berms
- Temporary vegetation to be established throughout the construction.
- Permanent re-vegetation shall occur after clearing and grubbing to prevent erosion. Permanent vegetation is established when the site is at a minimum of 70% stabilization

The prime contractor shall implement controls as needed to prevent erosion and adverse impacts on nearby streams and/or ponds. Vegetative practices shall be designed to preserve existing vegetation where feasible and initiate vegetative stabilization measures after land disturbing activities. Such practices may include, but not limited to, temporary seeding, permanent seeding, mulching, sod stabilization, vegetative buffer strips, tree protection and topsoil preservation. **When work is not being performed in a disturbed area or when a disturbed area is left dormant for fourteen (14) calendar days or**

more, appropriate temporary and/or permanent vegetative and structural practices shall be initiated immediately.

HOUSEKEEPING PRACTICES

The owner or prime contractor shall prevent pollutants from entering storm water from the construction site because of poor housekeeping. The owner or prime contractor shall designate areas for equipment maintenance/staging, fueling and repair that are located near the construction entrances. All fueling of equipment and vehicles on the site will be conducted in this area. Any spillage will be removed immediately. All fuel tanks will be kept in containment areas. Oils, other vehicle fluids, paints, solvents and other potentially toxic materials shall be stored in a construction trailer or storage container. The contractor is responsible for providing litter control for trash generated by his/her crew. Waste receptacles, if needed, shall be provided at convenient locations near the construction entrance which will be limited to garbage and paper trash as well as construction debris. Litter and construction debris exposed to storm water shall be picked up prior to any anticipated storm events or before being carried off the site by wind or construction traffic. Sanitary facilities shall be provided by the contractor to collect sanitary waste from his/her crew. These facilities shall be adequately maintained sanitary facilities and shall be emptied at the end of each working week or once they become full, whichever occurs first. Sanitary facilities shall be secured firmly to the ground to prevent wind-blown damage from occurring. Any existing pavements or roadways near the construction entrances shall be cleaned as needed to prevent tracking of sediment off-site. Where sediment has been tracked-out from the site onto adjacent paved roads, sidewalks or other paved areas, the contractor shall remove deposited sediment “immediately” by the end of the next work day. Sediment shall be removed by sweeping, shoveling, vacuuming or similar effective means of sediment removal.

IMPLEMENTATION SEQUENCE

The implementation sequence is as follows:

- Construct the construction entrance/exit.
- Install silt fencing as needed. (To be cleaned after silt build-up)
- Install brush barrier if needed
- Install temporary diversion berms and wattles as needed.
- Perform clearing and grubbing and vegetate as needed.

POST CONSTRUCTION/STORM WATER MANAGEMENT MEASURES

- Remove silt fencing and wattles after satisfactory vegetation cover is in place.
- Remove brush barriers by appropriate means.

INSPECTION/MAINTENANCE

A rain gage shall be set up on-site. Within 24 hours after commencement of a rainfall event of 2 inches or more, an inspection of all erosion controls and other S.W.P.P.P. requirements shall be performed during the permit coverage.

All accumulated sediment shall be removed from structural controls when sediment deposits reach 1/3 to 1/2 the height of the control. Accumulated sediment from the sedimentation pond shall be removed when the sediment reaches 50% capacity of the pond. All removed sediment deposits shall be properly disposed. Non-functioning controls shall be repaired, replaced or supplemented with functional controls within 24 hours of discovery or as soon as field conditions allow.

Make all needed repairs within 24 hours. Maintain all vegetated areas to provide proper ground cover-reseed, fertilize and mulch as needed.

Inspection of all temporary and vegetative, erosion and sediment controls, other protective measures and S.W.P.P.P. requirements shall be performed during permit coverage every seven days with a minimum of four (4) per month and after any rain events that produce a discharge to ensure appropriate erosion and sediment controls are being properly and adequately constructed and maintained. These inspections should be kept with the S.W.P.P.P. until such time the project is ready for termination of reporting and permit coverage. All records resulting from activities required shall be retained for a period of at least three (3) years from the date of the inspection or report.

STAFF TRAINING REQUIREMENTS

Each operator, or group of multiple operators, must assemble a stormwater team to carry out compliance activities associated with the requirements in this permit. Prior to beginning construction, the personnel on the stormwater team must understand the requirements of this SWPPP and their specific responsibilities.

1. Personnel responsibilities include but are not limited to the following:
2. Personnel who are responsible for the design, installation, maintenance, and/or repair of stormwater controls.
3. Personnel responsible for the application and storage of treatment chemicals, if applicable.
4. Personnel who are responsible for conducting inspections as required and;
5. Personnel who are responsible for taking corrective actions as required.

At a minimum, the stormwater team must be trained to understand applicable procedures to follow with respect to the SWPPP requirements. Each member of the stormwater team must have easy access to an electronic or paper copy of the approved permit, the most updated copy of the SWPPP, and other relative documents or information that must be kept with the SWPPP. Staff training associated with this SWPPP may be documented on the Employee Training Log provided. Employee training documentation shall be maintained on-site with the SWPPP and made available to MDEQ personnel for inspection upon request.

MDEQ Large Construction Notice of Intent



MISSISSIPPI DEPARTMENT OF
ENVIRONMENTAL QUALITY

**MISSISSIPPI DEPARTMENT OF
ENVIRONMENTAL QUALITY (MDEQ)
Large Construction Storm Water General Permit
NPDES Permit MSR10**

LARGE CONSTRUCTION FORMS PACKAGE

- **LARGE CONSTRUCTION NOTICE OF INTENT (LCNOI) FORM..... 2**
- **PRIME CONTRACTOR CERTIFICATION FORM..... 7**
- **REGISTRATION FORM FOR RESIDENTIAL LOT COVERAGE..... 8**
- **SITE INSPECTION AND CERTIFICATION FORM..... 12**
- **MAJOR MODIFICATION FORM..... 13**
- **REQUEST FOR TRANSFER OF PERMIT, GENERAL PERMIT COVERAGE
AND/OR NAME CHANGE 14**
- **INSPECTION SUSPENSION FORM..... 16**
- **REQUEST FOR TERMINATION OF COVERAGE 17**

These standard forms are used to apply for permit coverage under the Large Construction Storm Water General Permit and for submittals and record keeping required by permit conditions after coverage has been granted. The forms are on our website at www.deq.state.ms.us/MDEQ.nsf/page/epd_epdgeneral. Required information can be completed on screen, printed and signed.

AI: 87489

MSR109402

Rec'd via email:
10/03/2024



MISSISSIPPI DEPARTMENT OF
ENVIRONMENTAL QUALITY

LARGE CONSTRUCTION NOTICE OF INTENT (LCNOI) FOR COVERAGE UNDER THE LARGE CONSTRUCTION STORM WATER GENERAL NPDES PERMIT

INSTRUCTIONS

The Large Construction Notice of Intent (LCNOI) is for coverage under the Large Construction General Permit for land disturbing activities of five (5) acres or greater; or for land disturbing activities, which are part of a larger common plan of development or sale that are initially less than five (5) acres but will ultimately disturb five (5) or more acres. Applicant must be the owner or operator. For construction activities, the operator is typically the prime contractor. The owner(s) of the property and the prime contractor associated with regulated construction activity on the property have joint and severable responsibility for compliance with the Large Construction Storm Water General Permit MSR10.

If the company seeking coverage is a corporation, a limited liability company, a partnership, or a business trust, attach proof of its registration with the Mississippi Secretary of State and/or its Certificate of Good Standing. This registration or Certificate of Good Standing must be dated within twelve (12) months of the date of the submittal of this coverage form. Coverage will be issued in the company name as it is registered with the Mississippi Secretary of State.

Completed LCNOIs should be filed at least thirty (30) days prior to the commencement of construction. Discharge of storm water from large construction activities without written notification of coverage is a violation of state law.

Submittals with this LCNOI must include:

- A site-specific Storm Water Pollution Prevention Plan (SWPPP) developed in accordance with ACT5 of the General Permit
- A detailed site-specific scaled drawing showing the property layout and the features outlined in ACT5 of the General Permit
- A United States Geological Survey (USGS) quadrangle map or photocopy, extending at least one-half mile beyond the facility property boundaries with the site location and outfalls outlined or highlighted. The name of the quadrangle map must be shown on all copies. Quadrangle maps can be obtained from the MDEQ, Office of Geology at 601-961-5523.

Additional submittals may include the following, if applicable:

- Appropriate Section 404 documentation from U.S. Army Corps of Engineers
- Appropriate documentation concerning future disposal of sanitary sewage and sewage collection system construction
- Appropriate documentation from the MDEQ Office of Land & Water concerning dam construction and low flow requirements
- Approval from County Utility Authority in Hancock, Harrison, Jackson, Pearl River and Stone Counties

ALL QUESTIONS MUST BE ANSWERED (Answer "NA" if the question is not applicable)

O.C

APPLICANT IS THE: OWNER PRIME CONTRACTOR

OWNER CONTACT INFORMATION

OWNER CONTACT PERSON: _____

OWNER COMPANY LEGAL NAME: _____

OWNER STREET OR P.O. BOX: _____

OWNER CITY: _____ STATE: _____ ZIP: _____

OWNER PHONE #: (____) _____ OWNER EMAIL: _____

PRIME CONTRACTOR CONTACT INFORMATION

PRIME CONTRACTOR CONTACT PERSON: _____

PRIME CONTRACTOR COMPANY LEGAL NAME: _____

PRIME CONTRACTOR STREET OR P.O. BOX: _____

PRIME CONTRACTOR CITY: _____ STATE: _____ ZIP: _____

PRIME CONTRACTOR PHONE #: (____) _____ PRIME CONTRACTOR EMAIL: _____

FACILITY SITE INFORMATION

FACILITY SITE NAME: _____

FACILITY SITE ADDRESS (If the physical address is not available, please indicate the nearest named road. For linear projects indicate the beginning of the project and identify all counties the project traverses.)

STREET: _____

CITY: _____ STATE: _____ COUNTY: _____ ZIP: _____

FACILITY SITE TRIBAL LAND ID (N/A If not applicable): _____

LATITUDE: ____ degrees ____ minutes ____ seconds LONGITUDE: ____ degrees ____ minutes ____ seconds

LAT & LONG DATA SOURCE (GPS (Please GPS Project Entrance/Start Point) or Map Interpolation): _____

TOTAL ACREAGE THAT WILL BE DISTURBED ¹: _____

IS THIS PART OF A LARGER COMMON PLAN OF DEVELOPMENT? YES NO

IF YES, NAME OF LARGER COMMON PLAN OF DEVELOPMENT: _____
AND PERMIT COVERAGE NUMBER: MSR10 _____

ESTIMATED CONSTRUCTION PROJECT START DATE: _____
YYYY-MM-DD

ESTIMATED CONSTRUCTION PROJECT END DATE: _____
YYYY-MM-DD

DESCRIPTION OF CONSTRUCTION ACTIVITY: _____

PROPOSED DESCRIPTION OF PROPERTY USE AFTER CONSTRUCTION HAS BEEN COMPLETED: _____

SIC Code ____ NAICS Code _____

NEAREST NAMED RECEIVING STREAM: _____

IS RECEIVING STREAM ON MISSISSIPPI'S 303(d) LIST OF IMPAIRED WATER BODIES? (The 303(d) list of impaired waters and TMDL stream segments may be found on MDEQ's web site: http://www.deq.state.ms.us/MDEQ.nsf/page/TWB_Total_Maximum_Daily_Load_Section) YES NO

HAS A TMDL BEEN ESTABLISHED FOR THE RECEIVING STREAM SEGMENT? YES NO

ARE THERE RECREATIONAL STREAMS, PRIVATE/PUBLIC PONDS OR LAKES WITHIN ½ MILE DOWNSTREAM OF PROJECT BOUNDARY THAT MAY BE IMPACTED BY THE CONSTRUCTION ACTIVITY? YES NO

EXISTING DATA DESCRIBING THE SOIL (for linear projects please describe in SWPPP):

WILL FLOCCULANTS BE USED TO TREAT TURBIDITY IN STORM WATER? YES NO

IF YES, INDICATE THE TYPE OF FLOCCULANT. ANIONIC POLYACRYLAMIDE (PAM)
 OTHER _____

IF YES, DOES THE SWPPP DESCRIBE THE METHOD OF INTRODUCTION, THE LOCATION OF INTRODUCTION AND THE LOCATION OF WHERE FLOCCULATED MATERIAL WILL SETTLE? YES NO

¹Acreage for subdivision development includes areas disturbed by construction of roads, utilities and drainage. Additionally, a housesite of at least 10,000 ft² per lot (entire lot, if smaller) shall be included in calculating acreage disturbed.

DOCUMENTATION OF COMPLIANCE WITH OTHER REGULATIONS/REQUIREMENTS
COVERAGE UNDER THIS PERMIT WILL NOT BE GRANTED UNTIL ALL OTHER REQUIRED
MDEQ PERMITS AND APPROVALS ARE SATISFACTORILY ADDRESSED

IS LCNOI FOR A FACILITY THAT WILL REQUIRE OTHER PERMITS? YES NO

IF YES, CHECK ALL THAT APPLY: AIR HAZARDOUS WASTE PRETREATMENT
 WATER STATE OPERATING INDIVIDUAL NPDES OTHER: _____

IS THE PROJECT REROUTING, FILLING OR CROSSING A WATER CONVEYANCE OF ANY KIND? (If yes, contact the U.S. Army Corps of Engineers' Regulatory Branch for permitting requirements.) YES NO

IF THE PROJECT REQUIRES A CORPS OF ENGINEER SECTION 404 PERMIT, PROVIDE APPROPRIATE DOCUMENTATION THAT:

- The project has been approved by individual permit, or
- The work will be covered by a nationwide permit and NO NOTIFICATION to the Corps is required, or
- The work will be covered by a nationwide or general permit and NOTIFICATION to the Corps is required

IS A LAKE REQUIRING THE CONSTRUCTION OF A DAM BEING PROPOSED? YES NO
(If yes, provide appropriate approval documentation from MDEQ Office of Land and Water, Dam Safety.)

IF THE PROJECT IS A SUBDIVISION OR A COMMERCIAL DEVELOPMENT, HOW WILL SANITARY SEWAGE BE DISPOSED? Check one of the following and attach the pertinent documents.

- Existing Municipal or Commercial System. Please attach plans and specifications for the collection system and the associated "Information Regarding Proposed Wastewater Projects" form or approval from County Utility Authority in Hancock, Harrison, Jackson, Pearl River and Stone Counties. If the plans and specifications can not be provided at the time of LCNOI submittal, MDEQ will accept written acknowledgement from official(s) responsible for wastewater collection and treatment that the flows generated from the proposed project can and will be transported and treated properly. The letter must include the estimated flow.
- Collection and Treatment System will be Constructed. Please attach a copy of the cover of the NPDES discharge permit from MDEQ or indicate the date the application was submitted to MDEQ (Date: _____.)
- Individual Onsite Wastewater Disposal Systems for Subdivisions Less than 35 Lots. Please attach a copy of the Letter of General Acceptance from the Mississippi State Department of Health or certification from a registered professional engineer that the platted lots should support individual onsite wastewater disposal systems.
- Individual Onsite Wastewater Disposal Systems for Subdivisions Greater than 35 Lots. A determination of the feasibility of installing a central sewage collection and treatment system must be made by MDEQ. A copy of the response from MDEQ concerning the feasibility study must be attached. If a central collection and wastewater system is not feasible, then please attach a copy of the Letter of General Acceptance from the State Department of Health or certification from a registered professional engineer that the platted lots should support individual onsite wastewater disposal systems.

INDICATE ANY LOCAL STORM WATER ORDINANCE WITH WHICH THE PROJECT MUST COMPLY:

I certify under penalty of law that this document and all attachments were prepared under my direction or supervision in accordance with a system designed to assure that qualified personnel properly gathered and evaluated the information submitted. Based on my inquiry of the person or persons who manage the system, or those persons directly responsible for gathering the information, the information submitted is, to the best of my knowledge and belief, true, accurate and complete. I am aware that there are significant penalties for submitting false information, including the possibility of fine and imprisonment for knowing violations.

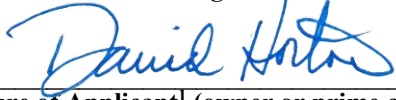

Signature of Applicant¹ (owner or prime contractor)

Date Signed

Printed Name¹

Title

¹This application shall be signed as follows:

- For a corporation, by a responsible corporate officer.
- For a partnership, by a general partner.
- For a sole proprietorship, by the proprietor.

For a municipal, state or other public facility, by principal executive officer, mayor, or ranking elected official

Please submit the LCNOI form to:

**Chief, Environmental Permits Division
MS Department of Environmental Quality, Office of Pollution Control
P.O. Box 2261
Jackson, Mississippi 39225**

PRIME CONTRACTOR CERTIFICATION

LARGE CONSTRUCTION GENERAL PERMIT

Coverage No. MSR10 _____ County _____

(Fill in your Certificate of Coverage Number and County)



By completing and submitting this form to MDEQ, the prime contractor is certifying that (1) they have operational control over the erosion and sediment control specifications (including the ability to make modifications to such specifications) or (2) they have day-to-day operational control of those activities at the site necessary to ensure compliance with the SWPPP and applicable permit conditions.

The owner(s) of the property and the prime contractor associated with regulated construction activity on the property have joint and severable responsibility for compliance with the permit. Notwithstanding any permit condition to the contrary, the coverage recipient and any person who causes pollution of waters of the state or places waste in a location where they are likely to cause pollution of any waters of the state shall remain responsible under applicable federal and state laws and regulations and applicable permits.

PRIME CONTRACTOR INFORMATION

PRIME CONTRACTOR CONTACT PERSON: _____ PHONE NUMBER: (____) _____

PRIME CONTRACTOR COMPANY: _____

PRIME CONTRACTOR STREET (P.O. BOX): _____

PRIME CONTRACTOR CITY: _____ STATE: _____ ZIP: _____

E-MAIL ADDRESS: _____

OWNER INFORMATION

OWNER CONTACT PERSON: _____ PHONE NUMBER: (____) _____

OWNER COMPANY NAME: _____

PROJECT INFORMATION

PROJECT NAME: _____

DESCRIPTION OF CONSTRUCTION ACTIVITY: _____

PHYSICAL SITE ADDRESS (If the physical address is not available indicate the nearest named road. For linear projects, indicate the beginning of the project and identify all counties the project traverses.)

STREET: _____

CITY: _____ COUNTY: _____

I certify that I am the prime contractor for this project and will comply with all the requirements in the above referenced general NPDES permit. I further certify under penalty of law that this document and all attachments were prepared under my direction or supervision in accordance with a system designed to assure that qualified personnel properly gathered and evaluated the information submitted. Based on my inquiry of the person or persons who manage the system, or those persons directly responsible for gathering the information, the information submitted is, to the best of my knowledge and belief, true, accurate and complete. I am aware that there are significant penalties for submitting false information, including the possibility of fine and imprisonment for knowing violations.

A handwritten signature in blue ink that reads "David Hinton".

Prime Contractor Signature¹

Date Signed

Printed Name¹

Title

- ¹This application shall be signed as follows:
- For a corporation, by a responsible corporate officer.
 - For a partnership, by a general partner.
 - For a sole proprietorship, by the proprietor.
 - For a municipal, state or other public facility, by principal executive officer, mayor, or ranking elected official.

This Prime Contractors Certification form shall be submitted to:

Chief, Environmental Permits Division
MS Department of Environmental Quality, Office of Pollution Control
P.O. Box 2261
Jackson, Mississippi 39225

Keep a Copy at the Construction Site and Also Submit this Page to:
 Chief, Environmental Permits Division
 MS Department of Environmental Quality, Office of Pollution Control
 P.O. Box 2261
 Jackson, Mississippi 39225-2261



Registration Form for Residential Lot Coverage under Mississippi's Large Construction Storm Water General Permit INSTRUCTIONS

Coverage recipients for residential subdivision construction that do not retain responsibility for permit compliance for individual lots are to furnish this Registration to buyers of individual lots at the time of purchase. In addition, the attached Requirements for Individual Lots in Residential Subdivisions, the Site Inspection and Certification Form and the Large Construction Storm Water General Permit shall also be given to buyers of individual lots at the time of purchase. This form is providing notification to buyers of lots in residential developments, that being part of a "larger common plan of development or sale," coverage is required under Mississippi's Large Construction Storm Water General Permit. To comply with the permit, **the Registration Form must be submitted to MDEQ** at the address listed above and a Storm Water Pollution Prevention Plan (SWPPP) must be developed and implemented to reduce pollutants in storm water discharges during construction activity. **The SWPPP is not required to be submitted to MDEQ.** A copy of the SWPPP and Registration Form must be kept at the construction site or locally available (i.e., able to be produced within an hour of being requested by a state or local inspector). See the following attachments for information on SWPPP development. In addition, **a copy of the completed Registration Form(s) must be retained by the developer and submitted to the MDEQ when requesting termination of permit coverage.** If the buyer or homebuilder sells the lot before a house is built, they must provide this form to the new owner. All questions must be answered. Answer "NA" if the question is not applicable. For further information, contact MDEQ at 601/961-5171 or access our website address: www.deq.state.ms.us/MDEQ.nsf/page/epd_epdgeneral.

ORIGINAL COVERAGE RECIPIENT NAME: _____ COMPANY NAME: _____ STREET OR P.O. BOX: _____ CITY: _____ STATE: _____ ZIP: _____ PHONE # (INCLUDE AREA CODE): _____	BUYER / HOMEBUILDER: _____ COMPANY NAME (IF APPROPRIATE): _____ STREET OR P.O. BOX: _____ CITY: _____ STATE: _____ ZIP: _____ BUYER PHONE # (INCLUDE AREA CODE): _____
---	---

RESIDENTIAL SUBDIVISION NAME: _____

LARGE CONSTRUCTION STORM WATER PERMIT COVERAGE NUMBER: MSR10: ____ ____ ____ ____

LOT NUMBER(s) (attach an additional sheet if necessary): _____ **LOT SIZE(s):** _____

PHYSICAL SITE ADDRESS (IF NOT AVAILABLE INDICATE THE NEAREST NAMED ROAD):

STREET: _____

CITY: _____ **COUNTY:** _____ **ZIP:** _____

I certify under penalty of law that this document and all attachments were prepared under my direction or supervision in accordance with a system designed to assure that qualified personnel properly gathered and evaluated the information submitted. Based on my inquiry of the persons or persons who manage the system, or those persons directly responsible for gathering the information, the information submitted is, to the best of my knowledge and belief, true, accurate and complete. I am aware that there are significant penalties for submitting false information, including the possibility of fine and imprisonment for knowing violations. As a buyer / homebuilder, I further certify that I have read and understand the terms and conditions of Mississippi's Large Construction Storm Water General Permit and that I am responsible for installing and maintaining the appropriate pollution control measures for the purchased lot(s) identified.

Original Coverage Recipient Signature¹	Date Signed
Printed Name	Title
Buyer / Homebuilder Signature¹	Date Signed
Printed Name	Title

¹This application shall be signed according to ACT11, T-7 of the Large Construction General Permit.

REQUIREMENTS FOR LOTS IN RESIDENTIAL SUBDIVISION WHICH ARE COVERED BY THE LARGE CONSTRUCTION STORM WATER GENERAL PERMIT

As a homebuilder on a lot that is part of a regulated subdivision, you are also regulated under the State's storm water regulations and are required to take steps to keep soil and sediment from leaving the lot. When rain falls on exposed soil it can wash away valuable topsoil. It also carries sediment, nutrients and other pollutants into streets, gutters and ditches, where it then travels to lakes, rivers, streams or wetlands. Polluted runoff can cause excessive growth of aquatic weeds and algae and reduce recreational opportunities such as swimming and fishing. Sediment laden runoff can also destroy fish habitat reducing productive fishing opportunities. In addition, sediment-laden runoff can also clog pipes, ditches, streams and basins resulting in increased flooding and maintenance cost. Therefore, the homebuilder is required to minimize off-site damage from soil erosion, sediment leaving the construction site, and poor "housekeeping" practices. This requirement must be accomplished by developing and implementing a Storm Water Pollution Prevention Plan (SWPPP). Some examples of individual lot SWPPPs are attached for your convenience. Sketch the controls on a copy of your site plan. Narrative notes on the site plan may also be used in addition to the erosion control symbols.

In developing and implementing the SWPPP, controls must be used from each control group (vegetative, structural, housekeeping) to prevent erosion and sediment and other pollutants from leaving the site. Commonly used controls include:

Vegetative Controls

Temporary vegetation includes annual grasses that sprout quickly such as annual rye, browntop millet, oats, and winter wheat. These grow quickly with little care and can protect the soil from rainfall and act as a filter. They will not provide permanent cover. Permanent cover must be established as indicated below. When a disturbed area will be left undisturbed for fourteen (14) days or more, the appropriate temporary or permanent vegetative practices shall be implemented immediately.

Mulching is the placement of hay grass, woodchips, straw, or synthetic material on the soil to provide temporary cover to protect the soil from rain. Mulching may be the only option during the winter when seeding or sodding is not possible. Mulch must stay in place to be effective. Netting, stakes or chemical binders are used to anchor some types of mulch. Be sure to reinstall washed-out mulch and anchor if necessary until permanent cover is established.

Permanent stabilization is the establishment of a permanent vegetative cover on disturbed areas using either sod, perennial seed, trees or shrubs. When a disturbed area will be left undisturbed for fourteen (14) days or more, the appropriate temporary or permanent vegetative practices shall be implemented immediately. Silt fences, and other temporary measures must be removed following permanent stabilization.

Vegetative buffer zones are undisturbed or planted vegetated areas that are between construction activities and water bodies.

Structural Controls

Silt fences are temporary sediment barriers made of filter fabric buried at the bottom, stretched, and supported by stakes. The silt fence slows runoff and allows it to puddle or pond, so soil and sediment can settle out before leaving the site. The bottom eight to twelve inches of fence must either be sliced in or buried in a trench about four to six inches deep by four to six inches wide. **Silt fences that are not buried are improperly installed. They have no useful function, are a waste of money, and may result in enforcement action.** Stakes must be on the downstream side of the fence and spaced about 3 feet apart. Silt fence must not be installed across streams, ditches, waterways, or other concentrated flow areas. Place fences on the contour or perpendicular to the slope of the hill so that water and sediment will pond behind the fence. **Turn ends uphill** to prevent water going around the end. Install on the downslope, downhill, downstream, or low side of your lot. Keep the fence/barrier in place until grass is established.

Slope drains are piping or lined channels that carry storm water downslope without erosion. A good example would be a downspout extender. Extenders may be used to protect temporarily stabilized areas from roof runoff. Extenders can direct water from roof gutters to paved or grassed areas. Remove extenders following permanent stabilization.

Construction entrance/exits are stone stabilized site entrances which reduce sediment tracked onto public roads. Apply gravel or crushed rock to the driveway area and restrict traffic to this one route. Use 3 to 6 inch gravel over a geotextile fabric. At the end of each day sweep or scrape up any soil tracked onto the street. Limit "standard" vehicle access (including workers' vehicles) to only streets and roads, keep vehicles off of future yard areas; limit tracking of mud onto streets by requiring any required vehicles to use designated access drives. Streets are conduits for storm water, it is important to keep mud and sediment off the streets.

Stockpiles of sand or soil should be covered with plastic or tarps at the end of each workday, or surrounded with silt fence or haybales. Do not locate a stockpile near a street, storm drain inlet, or ditch.

Erosion control blankets or mats are machine-produced mats of straw or other fibers held together with netting that provide temporary or permanent stabilization in critical areas, such as slopes or channels, so that vegetation may be established.

Storm Drain Inlets on the lot must be protected by surrounding or covering with a filter material until final stabilization has been achieved.

Additional Controls: The above controls are the more common practices used at small construction sites. There are a number of other controls, techniques and manufactured product available. A few examples include hydro seeding, diversion berms, silt dikes and fiber logs. Even something as simple as a tarp or plastic may provide temporary cover for small exposed areas. You may wish to contact an erosion and sediment control specialist, local building official, or MDEQ for further information. In addition, MDEQ has several guidance manuals that may be of assistance and the internet has abundant guidance on construction BMPs.

Housekeeping Controls: Pollutants that may enter storm water from construction sites because of poor housekeeping include oils, grease, paints, gasoline, solvents, litter, debris, and sanitary waste. Good housekeeping practices include:

- Frequent cleaning of trash and debris, providing waste receptacles at convenient locations and providing regular collection of waste;
- Directing concrete trucks to the subdivision's designated wash-off area(s) or back to the Ready-Mix facility;
- Providing protected storage areas for chemicals, paints, solvents, fertilizers, and other potentially toxic materials; and
- Providing adequately maintained sanitary facilities.

In addition, you should be aware that State air regulations prohibit the open burning of residential solid waste.

Inspection Requirements. Homebuilders shall inspect all erosion controls as often as is necessary, but no less than weekly, to ensure that appropriate erosion and sediment controls have been properly constructed and maintained to prevent erosion and sediment from leaving the site and determine if additional or alternative control measures are required. The inspection results shall be recorded on the Site Inspection and Certification Form contained in the Large Construction Forms Package. MDEQ strongly recommends that homebuilders perform "walk through" inspections daily. It is a responsibility of the homebuilder to install additional and/or alternative erosion and sediment controls when existing controls prove to be ineffective in preventing sediment from leaving the site.

Retention of Records. All records, reports, forms and information resulting from activities required by this permit shall be retained for a period of at least three years from the date of the document origin.

Duty to Comply. Lot owners must comply with the applicable permit conditions. See Activities 3, 5, 6, 7, 10 and 11 in the Large Construction Storm Water General Permit for applicable conditions. Any noncompliance with the applicable permit conditions and aforementioned conditions including sediment leaving the lot constitutes a violation of the Mississippi Water Pollution Control Law and is grounds for enforcement action. It shall not be an acceptable defense that controls were not installed because subsequent activities would require their replacement or cause their destruction.

EXAMPLE INDIVIDUAL LOT EROSION AND SEDIMENT CONTROL PLANS

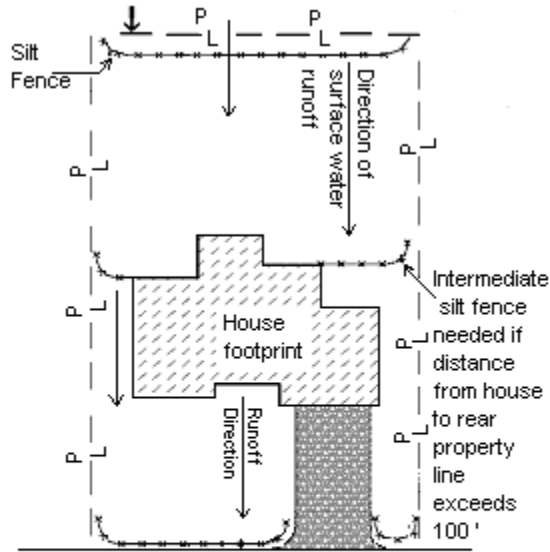

- Street
- Silt Fence
- ▨ Gravel construction entrance
- ← Runoff direction
- P Property Line
- L

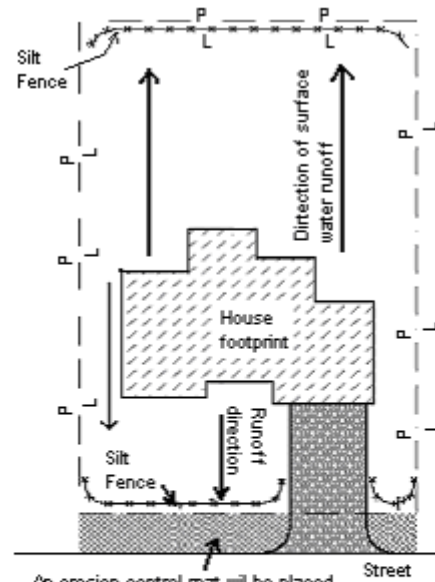

- Street
- Silt fence
- ▨ Gravel construction entrance
- ← Direction of surface water runoff
- ▨ Erosion control mat
- P Property Line
- L

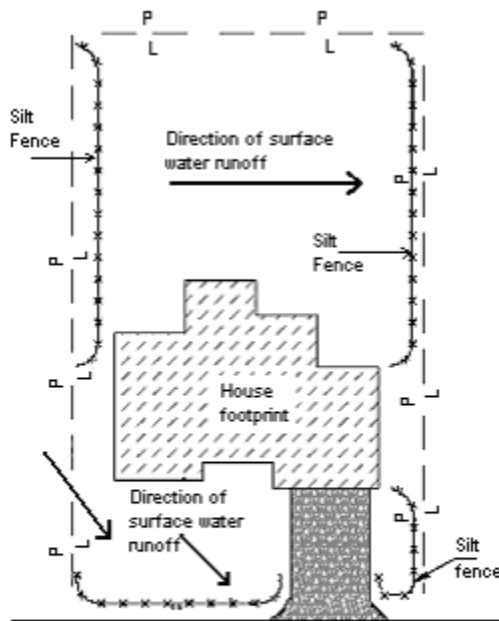

- Street
- Silt fence
- ▨ Gravel construction entrance
- ← Direction of surface water runoff
- P Property Line
- L

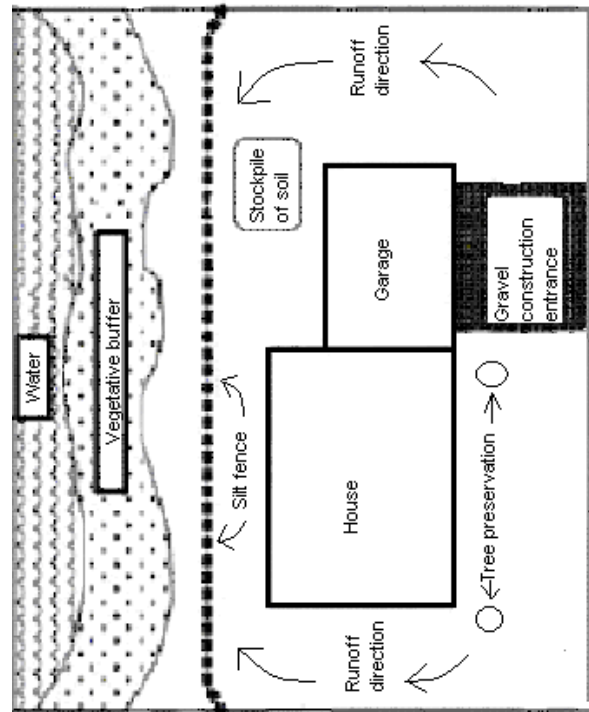

All disturbed areas will be temporarily seeded with ryegrass. After final grade has been reached, all disturbed areas will be sodded with bermuda grass.

**Keep a Copy Available at the Permitted Facility or Locally Available
Submit the Inspection Reports Only if Requested by the Mississippi Department of Environmental Quality (MDEQ)**

**LARGE CONSTRUCTION GENERAL PERMIT
SITE INSPECTION AND CERTIFICATION FORM
COVERAGE NUMBER (MSR10 _ _ _ _)**



INSTRUCTIONS

Results of construction storm water inspections required by ACT6 of this permit shall be recorded on this report form and kept with the Storm Water Pollution Prevention Plan (SWPPP) in accordance with the inspection documentation provisions of ACT9 of the this permit. Inspections shall be performed at least weekly for a minimum of four inspections per month. The coverage number must be listed at the top of all Inspection and Certification Forms.

COVERAGE RECIPIENT INFORMATION

OWNER/PRIME CONTRATOR NAME: _____

PROJECT NAME: _____

PROJECT STREET ADDRESS: _____

PROJECT CITY: _____ **PROJECT COUNTY:** _____

OWNER/PRIME CONTRACTOR MAILING ADDRESS: _____

MAILING CITY: _____ **STATE:** _____ **ZIP:** _____

CONTACT PERSON: _____ **CONTACT PHONE NUMBER: (_____)** _____

EMAIL ADDRESS: _____

INSPECTION DOCUMENTATION

DATE (mo/day/yr)	TIME (hr:min AM/PM)	ANY DEFICIENCIES? (CHECK IF YES)	INSPECTOR(S)
		<input type="checkbox"/>	
		<input type="checkbox"/>	
		<input type="checkbox"/>	
		<input type="checkbox"/>	
		<input type="checkbox"/>	
		<input type="checkbox"/>	

Deficiencies Noted During any Inspection (give date(s); attach additional sheets if necessary): _____

Corrective Action Taken or Planned (give date(s); attach additional sheets if necessary): _____

Based upon this inspection, which I or personnel under my direct supervision conducted, I certify that all erosion and sediment controls have been implemented and maintained, except for those deficiencies noted above, in accordance with the Storm Water Pollution Prevention Plan (SWPPP) and sound engineering practices as required by the above referenced permit. I further certify that the LCNOI and SWPPP information is up to date.

I certify under penalty of law that this document and all attachments were prepared under my direction or supervision in accordance with a system designed to assure that qualified personnel properly gather and evaluate the information submitted. Based on my inquiry of the person or persons responsible for gathering the information, the information submitted is, to the best of my knowledge and belief, true, accurate and complete. I am aware that there are significant penalties for submitting false information, including the possibility of fines and imprisonment for knowing violations.

Authorized Signature

Date

Printed Name

Title

**MAJOR MODIFICATION FORM
FOR LARGE CONSTRUCTION GENERAL PERMIT**
Coverage No. MSR10 _____ County _____



MISSISSIPPI DEPARTMENT OF ENVIRONMENTAL QUALITY

INSTRUCTIONS

Coverage recipients shall notify the Mississippi Department of Environmental Quality at least 30 days in advance of the following activities (check all that apply). This form should be submitted with a modified Storm Water Pollution Prevention Plan (SWPPP), updated USGS topographic map, Corps of Engineers Section 404 documentation and wastewater collection and treatment information, as appropriate.

SWPPP details have been developed and are ready for MDEQ review for subsequent phases of an existing, covered project.

"Footprint" identified in the original LCNOI is proposed to be enlarged.

This form must be signed by the current coverage recipient under Mississippi's Large Construction General Permit. A different developer of new phases of existing subdivisions must apply for separate permit coverage through the submittal of a new complete LCNOI package. Coverage recipients are authorized to discharge storm water associated with proposed expansions of existing subdivisions or subsequent phases, under the conditions of the General Permit, only upon receipt of written notification of approval by MDEQ. All other modifications, such as changes of erosion and sediment controls used, must be in accordance with ACT6, S-1 (6) and S-2 (7) of the General Permit.

ALL INFORMATION MUST BE COMPLETED (indicate "N/A" where not applicable)

COVERAGE RECIPIENT INFORMATION

COVERAGE RECIPIENT CONTACT NAME: _____ TEL # (____) _____

COMPANY NAME: _____

STREET OR P.O. BOX: _____

CITY: _____ STATE: _____ ZIP: _____ E-MAIL: _____

PROJECT INFORMATION

PROJECT NAME: _____

CITY: _____

ADDITIONAL ACREAGE TO BE DISTURBED: _____ TOTAL PROJECT ACREAGE: _____

I certify under penalty of law that this document and all attachments were prepared under my direction or supervision in accordance with a system designed to assure that qualified personnel properly gathered and evaluated the information submitted. Based on my inquiry of the person or persons who manage the system, or those persons directly responsible for gathering the information, the information submitted is, to the best of my knowledge and belief, true, accurate and complete. I am aware that there are significant penalties for submitting false information, including the possibility of fine and imprisonment for knowing violations.

Signature (must be signed by coverage recipient)

Date

Printed Name

Title

Please submit this form to:

Chief, Environmental Permits Division
MS Department of Environmental Quality, Office of Pollution Control
P.O. Box 2261
Jackson, Mississippi 39225

Environmental Permits for Industrial Facilities

Request for Transfer of Permit, General Permit Coverage and/or Name Change

Instructions: For Ownership Change-Complete all Items on Page 1 (except Item VIII) and Page 2 (reverse side).
 For Name Change Only-Complete Items I, II, V, VI, VII, VIII, and Page 2 (reverse side).

Note-This form should be submitted to MDEQ when a transferal date is finalized but prior to the actual transfer.

<p>Item I.</p> <p>Facility Name: _____</p> <p>Location: (Do Not Use P.O. Box)</p> <p style="padding-left: 40px;">Street: _____</p> <p style="padding-left: 40px;">City: _____ State: <u>MS</u> Zip: _____</p> <p>County: _____</p> <p>Telephone: (_____) _____</p>	<p>Item II.</p> <p>Responsible official after transfer or name change:</p> <p>Name: _____</p> <p>Title: _____</p> <p>Mailing Address:</p> <p style="padding-left: 40px;">Street/P.O. Box: _____</p> <p style="padding-left: 40px;">City: _____ State: _____ Zip: _____</p> <p>Telephone (_____) _____</p>								
<p>Item III.</p> <p>Previous Permittee¹: _____</p> <p>Mailing Address:</p> <p style="padding-left: 40px;">Street/P.O. Box: _____</p> <p style="padding-left: 40px;">City: _____ State: _____ Zip: _____</p> <p>Telephone: (_____) _____</p>	<p>Item IV.</p> <p>New Permittee¹: _____</p> <p>Mailing Address:</p> <p style="padding-left: 40px;">Street/P.O. Box: _____</p> <p style="padding-left: 40px;">City: _____ State: _____ Zip: _____</p> <p>Telephone: (_____) _____</p>								
<p>Item V.</p> <p>Industrial Activity SIC Code: _____</p> <p>Brief Description:</p>	<p>Item VI.</p> <p>Will Facility Operations Change? Yes _____ No _____</p> <p>If yes, the appropriate applications and permits may require modification prior to change.</p>								
<p>Item VII.</p> <p>Will Facility Name Change? Yes _____ No _____</p> <p>If Yes, Provide New Name for Permit Coverage.</p> <p>New Name: _____</p>	<p>Item VIII.</p> <p>Signature for Name Change</p> <p>Print Name: _____</p> <p>Authorized Signature²: _____</p> <p>Title: _____ Date: _____</p>								
<p>Item IX.</p> <p>We the undersigned request transfer of permit(s) and/or permit coverage(s) listed on the backside of this form.</p> <p>From: _____</p> <p>To: _____ Acquisition Date: _____</p> <p>By signature below, the recipient certifies that: 1) they are aware of the requirements of the permit(s), 2) the applicant can demonstrate to the Permit Board it has the financial resources and operational expertise and 3) agrees to accept responsibility and liability for the permit(s) listed on the back of this document. By signature below, the previous permittee is requesting that the permit(s) and/or permit coverage(s) be transferred to the recipient. The transfer of the permit(s) or permit coverage(s) will be by written notification from the Office of Pollution Control (OPC). The OPC may require submittal of information regarding financial capability and past compliance history of the recipient.</p> <table style="width: 100%; border: none;"> <tr> <td style="width: 50%; border: none;"> <p>_____</p> <p>Print New Permittee¹ Name</p> </td> <td style="width: 50%; border: none;"> <p>_____</p> <p>Print Previous Permittee¹ Name</p> </td> </tr> <tr> <td style="border: none;"> <p>_____</p> <p>New Authorized Signature²</p> </td> <td style="border: none;"> <p>_____</p> <p>Previous Authorized Signature²</p> </td> </tr> <tr> <td style="border: none;"> <p>_____</p> <p>Title</p> </td> <td style="border: none;"> <p>_____</p> <p>Title</p> </td> </tr> <tr> <td style="border: none;"> <p>_____</p> <p>Date</p> </td> <td style="border: none;"> <p>_____</p> <p>Date</p> </td> </tr> </table>		<p>_____</p> <p>Print New Permittee¹ Name</p>	<p>_____</p> <p>Print Previous Permittee¹ Name</p>	<p>_____</p> <p>New Authorized Signature²</p>	<p>_____</p> <p>Previous Authorized Signature²</p>	<p>_____</p> <p>Title</p>	<p>_____</p> <p>Title</p>	<p>_____</p> <p>Date</p>	<p>_____</p> <p>Date</p>
<p>_____</p> <p>Print New Permittee¹ Name</p>	<p>_____</p> <p>Print Previous Permittee¹ Name</p>								
<p>_____</p> <p>New Authorized Signature²</p>	<p>_____</p> <p>Previous Authorized Signature²</p>								
<p>_____</p> <p>Title</p>	<p>_____</p> <p>Title</p>								
<p>_____</p> <p>Date</p>	<p>_____</p> <p>Date</p>								

¹A Permittee is a company or individual that has been issued an individual permit or coverage under a general permit.

²Authorized Signature must be owner or in the case of a corporation, a corporate officer as defined in Regulations 11 Miss. Admin. Code Pt. 2, Ch. 2. and 11 Miss. Admin. Code Pt. 6, Ch. 1.

Mississippi Department of Environmental Quality/Office of Pollution Control
P.O. Box 2261
Jackson, Mississippi 39225
(601) 961-5171

<p>Item X. Storm Water</p> <p>(Check One)</p> <p><input type="checkbox"/> A Storm Water Pollution Prevention Plan (SWPPP) is not required for the site.</p> <p><input type="checkbox"/> The recipient certifies that they have received a copy of the Office of Pollution Control approved SWPPP from the original owner.</p> <p><input type="checkbox"/> The recipient is submitting a new SWPPP, which is attached to this form.</p> <p><input type="checkbox"/> A copy of the SWPPP cannot be obtained from the original owner.</p>	<p>Item XI. Hazardous Waste ID Number</p> <p>EPA ID No. _____</p> <p>(Check One)</p> <p><input type="checkbox"/> An EPA Hazardous Waste ID Number is not required for the site.</p> <p><input type="checkbox"/> The site's EPA ID Number is listed above and a Notification of Regulated Waste Activity Form is attached.</p>
--	---

Item XII. Permit(s) and/or Coverage(s) to be Transferred	
---	--

Permit Type: _____ Permit/Coverage No.: _____ Permit Issuance Date: _____ Date of General Permit Coverage: _____ Permit Expiration Date: _____	Permit Type: _____ Permit/Coverage No.: _____ Permit Issuance Date: _____ Date of General Permit Coverage: _____ Permit Expiration Date: _____
--	--

Permit Type: _____ Permit/Coverage No.: _____ Permit Issuance Date: _____ Date of General Permit Coverage: _____ Permit Expiration Date: _____	Permit Type: _____ Permit/Coverage No.: _____ Permit Issuance Date: _____ Date of General Permit Coverage: _____ Permit Expiration Date: _____
--	--

Permit Type: _____ Permit/Coverage No.: _____ Permit Issuance Date: _____ Date of General Permit Coverage: _____ Permit Expiration Date: _____	Permit Type: _____ Permit/Coverage No.: _____ Permit Issuance Date: _____ Date of General Permit Coverage: _____ Permit Expiration Date: _____
--	--

Permit Type: _____ Permit/Coverage No.: _____ Permit Issuance Date: _____ Date of General Permit Coverage: _____ Permit Expiration Date: _____	OTHER INFORMATION:
--	--

INSPECTION SUSPENSION FORM

UNDER LARGE CONSTRUCTION STORM WATER GENERAL NPDES PERMIT MSR10



MISSISSIPPI DEPARTMENT OF
ENVIRONMENTAL QUALITY

INSTRUCTIONS

Coverage recipients under Mississippi's Large Construction Storm Water General Permit may temporarily suspend required weekly inspections of erosion and sediment controls and monthly record keeping by submission of this form. Inspections may be suspended only when land disturbing activities have ceased, no further land disturbing activities are planned for a period of at least six (6) months, the site is stable with no active erosion, and vegetative cover has been established (see ACT9, S-1). The coverage recipient is responsible for all permit conditions during the suspension period and nothing in this condition shall limit the rights of MDEQ to take enforcement or other actions against the coverage recipient. Once land disturbing activities resume MDEQ must be notified and all inspections and record keeping required by the permit must also resume. Color photographs, representative of the construction site, must be submitted with this inspection form.

COVERAGE RECIPIENT INFORMATION

COVERAGE RECIPIENT CONTACT PERSON: _____

COMPANY NAME: _____

STREET OR P.O. BOX: _____

CITY: _____ STATE: _____ ZIP: _____

PHONE # (INCLUDE AREA CODE): _____ E-MAIL: _____

PROJECT INFORMATION

CONSTRUCTION STORM WATER GENERAL PERMIT COVERAGE NUMBER: **MSR10** _____

PROJECT NAME: _____

CITY: _____ COUNTY: _____

I certify under penalty of law that this document and all attachments were prepared under my direction or supervision in accordance with a system designed to assure that qualified personnel properly gathered and evaluated the information submitted. Based on my inquiry of the person or persons who manage the system, or those persons directly responsible for gathering the information, the information submitted is, to the best of my knowledge and belief, true, accurate and complete. I am aware that there are significant penalties for submitting false information, including the possibility of fine and imprisonment for knowing violations. **I further certify that: land disturbing activities have ceased, no further land disturbing activities are planned for a period of at least six (6) months, the site is stable with no active erosion, and vegetative cover has been established.**

Signature (must be signed by coverage recipient)

Date Signed

Printed Name

Title

Please submit this form to:

Chief, Environmental Permits Division
MS Department of Environmental Quality, Office of Pollution Control
P.O. Box 2261
Jackson, Mississippi 39225

Request for Termination (RFT) of Coverage



LARGE CONSTRUCTION GENERAL PERMIT
Coverage No. MSR10 _____ **County** _____
(Fill in your Certificate of Coverage Number and County)

This form must be submitted within thirty (30) days of achieving final stabilization (see ACT10, S-1 of general permit). Failure to submit this form is a violation of permit conditions.

The signatory of this form must be the owner or operator (prime contractor) who is the current coverage recipient (rather than the project manager or environmental consultant).

(Please Print or Type)

Project Name: _____

Physical Site Street Address (if not available, indicate nearest named road): _____

City: _____ **County:** _____ **Zip:** _____

Coverage Recipient Company Name: _____

Street Address / P.O. Box: _____

City: _____ **State:** _____ **Zip:** _____

Coverage Recipient Contact Name and Position: _____ **Tel. #:** (____) _____

Has another owner(s) or operator(s) assumed control over all areas of the site that have not reached final stabilization?

RESIDENTIAL SUBDIVISIONS:

- YES. A copy of the Registration Form for Residential Lot Coverage for each lot or out parcel that has been sold and a site map, indicating which lots have been sold, are attached.**
- NO. Coverage may not be terminated until all areas have reached final stabilization.**

COMMERCIAL DEVELOPMENT:

- YES. A copy of the site map, indicating which out-parcels have been sold, is attached.**
- NO. Coverage may not be terminated until all areas have reached final stabilization.**

I certify under penalty of law that this document and all attachments were prepared under my direction or supervision in accordance with a system designed to assure that qualified personnel properly gathered and evaluated the information submitted. Based on my inquiry of the person or persons who manage the system, or those persons directly responsible for gathering the information, the information submitted is, to the best of my knowledge and belief, true, accurate and complete. I am aware that there are significant penalties for submitting false information, including the possibility of fines and imprisonment for knowing violations. I understand that by submitting this Request for Termination and receiving written confirmation, I will no longer be authorized to discharge storm water associated with construction activity under this general permit. Discharging pollutants associated with construction activity to waters of the State without proper permit coverage is a violation of state law. I also understand that the submittal of this Request for Termination does not release an owner or operator from liability for any violations of this permit or the Clean Water Act.

Authorized Name (Print) Telephone Signature Date Signed

¹This application shall be signed according to the General Permit, ACT11, T-7 as follows:

- For a corporation, by a responsible corporate officer.
- For a partnership, by a general partner.
- For a sole proprietorship, by the proprietor.
- For a municipal, state or other public facility, by principal executive officer, mayor, or ranking elected official.

After signing please mail to: Chief, Environmental Permits Division
MS Department of Environmental Quality, Office of Pollution Control
P.O. Box 2261
Jackson, Mississippi 39225

City of Meridian Will Serve Letter

Approved MDOT Grading Permit

5-24-38-20 59-0446

Willie Simmons
Central District Commissioner

Earl Glenn, Jr., P.E.
Deputy Executive Director/Chief Engineer

Neil Patterson, P.E.
District 5 Engineer



Brad White
Executive Director

Jeff Ely, P.E.
Chief of Staff

Lisa M. Hancock
Deputy Executive Director/Administration

September 23, 2024

Century Construction

RE: PERMIT # 5-24-38-20-59-0446

Dear Sir:

Enclosed please find approved application and plan for permission to remove material on Hwy 20/59 in Lauderdale County, as submitted by you.

This application approved as far as content and dimensions are concerned. You are requested to advise the District Permit Office of the Mississippi Department of Transportation 48 hours in advance of beginning construction of this project. Final approval to begin construction will be given verbally at that time. Telephone number of the District Permit Office is 601- 683-3771. Construction shall NOT BEGIN until the Permit Office is notified.

You are request to notify the Permit Department (601- 683-3771) at the completion of this project so that we might make a final installation inspection.

Very Truly Yours

NEIL PATTERSON, DISTRICT ENGINEER

BY:
Marty Hollingsworth
Permit Officer

Attachments

MND-004
Rev. 2011

PERMIT NO. _____

Applicant Contact Name: _____

Applicant Contact Phone #: _____

**MISSISSIPPI DEPARTMENT OF TRANSPORTATION
APPLICATION FOR PERMIT TO LOCATE CERTAIN FACILITIES
ON OR TO PERFORM CERTAIN WORK ON STATE
HIGHWAY RIGHT OF WAY**

(Please Print) Name: _____ Address: _____
Company (or) Individual Street/Route

City County State Zip Code

herein called the applicant, who does hereby make application to the Mississippi Department of Transportation, the duly authorized agent for the Mississippi Transportation Commission, for permission to _____

_____ on or across

Highway No. _____ between _____ and _____

Latitude (decimal degrees) _____ Longitude (decimal degrees) _____

in _____ County, Mississippi and in consideration of this permit being granted, said applicant does hereby agree to perform the above work in accordance with the plan shown herein below and does further agree, with full understanding of the terms thereof, to the following provisions:

- (a) That the Mississippi Department of Transportation does not purport to grant to said applicant any right, title, claim or easement in or upon said highway or right-of-way appurtenant thereto.
- (b) The plan of the proposed work or facility set out below or attached hereto is incorporated herein by reference and made a part of this application as if fully described herein by words and figures.
- (c) It is agreed that this permit is void if all work shown on this plan is not completed in accordance with this plan within one year after date of approval.
- (d) It is agreed that no trees or shrubs on the highway right-of-way will be cut, trimmed, or damaged during the process of the proposed work or maintenance of this work or facility except as shown on the plan.
- (e) All sod disturbed by the proposed work shall be neatly dressed and grassed in accordance with the vegetation schedule outlined elsewhere in this permit. The applicant shall maintain the dressed and grassed area for a sufficient length of time to insure a growing sod.
- (f) The applicant is responsible for any conflicts with other utilities on the highway right-of-way and is to secure permission from said utilities for any necessary alterations.
- (g) The Mississippi Department of Transportation may at any time require and compel the removal or relocation of any facility herein described, shown or referred to, when said Mississippi Department of Transportation deems it necessary. All expense of said removal or relocation is to be borne exclusively by the applicant, and the Mississippi Department of Transportation is to be in no way liable.
- (h) The applicant accepts the responsibility of the safety of the traveling public and his/her workers and agrees to furnish, place and maintain traffic control devices, if required, in accordance with Part 6 of the Manual On Uniform Traffic Control Devices For Streets and Highways (MUTCD), Current Edition as a minimum. The applicant shall attach a special traffic control plan to the application if special traffic control details are required.
- (i) All work associated with this permit shall be designed, detailed and constructed in accordance with the Department's Roadway and Bridge Design Manuals and Standard Drawings and the Mississippi Standard Specifications for Road and Bridge Construction.
- (j) The Mississippi Department of Transportation in granting this permit does not in any way assume the maintenance or upkeep of the facility or proposed improvement herein described. Nor, will the Mississippi Department of Transportation be held responsible for any damage, which may be inadvertently done to this facility or proposed improvement regardless of the source or cause of such damage.
- (k) A copy of the approved plan is to be kept at the site of the work at all times while work is in progress.
- (l.) Said applicant hereby expressly agrees for himself, his heirs, assigns and legal representatives, that upon request of said Mississippi Department of Transportation, he will without delay either reconstruct, remove or move the facility herein described to another location, all in accordance with the terms of the request so made by the said Mississippi Department of Transportation. It is distinctly understood that said new location will be made or designated by said Mississippi Department of Transportation after agreement with said applicant or its successors, if possible. It is further understood and agreed that, if this permit is granted and acted upon by the said applicant, the said Mississippi Department of Transportation will use all reasonable effort to avoid the necessity of requesting that the herein mentioned facility be removed, moved, altered, or reconstructed.

MND-004
Rev. 2011

PERMIT NO. _____

(m.) The applicant does hereby covenant and agree to indemnify and hold harmless the Mississippi Transportation Commission and the Mississippi Department of Transportation from and against any claims, actions, suits, causes or demands, including court costs and reasonable attorney's fees, proximately resulting from acts or omissions of the applicant, or applicant's servants, agents or employees in the construction and maintenance of all facilities outlined under this permit.

Witness my signature this 6th day of August 2024 which is applicable to sheets 1
through 9 of permit number _____

[Handwritten Signature]
Signature of Applicant
By: Colin Maloney, President
Printed Name and Title

STATE OF MISSISSIPPI
COUNTY OF Lee

Personally appeared before me, the undersigned authority, Colin Maloney whose
Printed Name of Applicant
names(s) is subscribed to this instrument as the President of
is/are Title of Applicant
Century Construction Group, Inc. who having been first fully sworn acknowledged that they
Name of Company (or) Individual

executed the above agreement as the act and deed of the said applicant for the purpose and consideration and in the capacity therein expressed and on the date above written.

Given under my hand and seal of office this the 6th day of August 2024

My Commission Expires: 10/31/2027

[Handwritten Signature]
Signature of Notary Officer



Field Inspection By: Marty Hollingsworth 9/19/2024

Approved: MISSISSIPPI DEPARTMENT OF TRANSPORTATION
Earl Glenn 9-23-2024
Deputy Executive Director/Chief Engineer

By: *[Handwritten Signature]* 9-23-2024

Installation Inspection By: _____ 20____

Mississippi Department of Transportation
Completion of Work Certification

This permit requires that the named applicant submit the following certification with signature(s) and insure proper filing with MDOT's District Permit Department before the permit is closed and all associated bonds are released:

Permit Representative's signature(s) acknowledges the following:

We/(I), certify that the requirements of this permit have been constructed as stated in the approved final permit. Furthermore, no work performed as an exercise of the approved permit, has been relocated or altered without such change being shown on an approved revision of the permit or approved addenda thereto.

Printed Name of Applicant

Signature of Applicant

Sheet No.: 3 of 11

Permit No.: _____

NOTE:

STATIONING REFERENCED FROM MDOT PROJECT
NO. IMD-0059-03(084) SHEET NO. 59

AFTER GRADING OPERATIONS, RIGHT-OF-WAY
MARKER 958+66.99 SHALL BE RE-SET BY A
PROFESSIONAL ENGINEER/SURVEYOR

REVISIONS			
APPLICANT		MDOT	
DATE	BY	DATE	BY



Show North



MND-005
Rev. 2-93

MISSISSIPPI DEPARTMENT OF TRANSPORTATION

Supplement to:
MND-001
MND-002
MND-004

Sheet No.: 4 of 11

Permit No.: _____

NOTE:

STATIONING REFERENCED FROM MDOT PROJECT
NO. IMD-0059-03(084) SHEET NO. 59

AFTER GRADING OPERATIONS, RIGHT-OF-WAY
MARKER 958+66.99 SHALL BE RE-SET BY A
PROFESSIONAL ENGINEER/SURVEYOR

REVISIONS			
APPLICANT		MDOT	
DATE	BY	DATE	BY

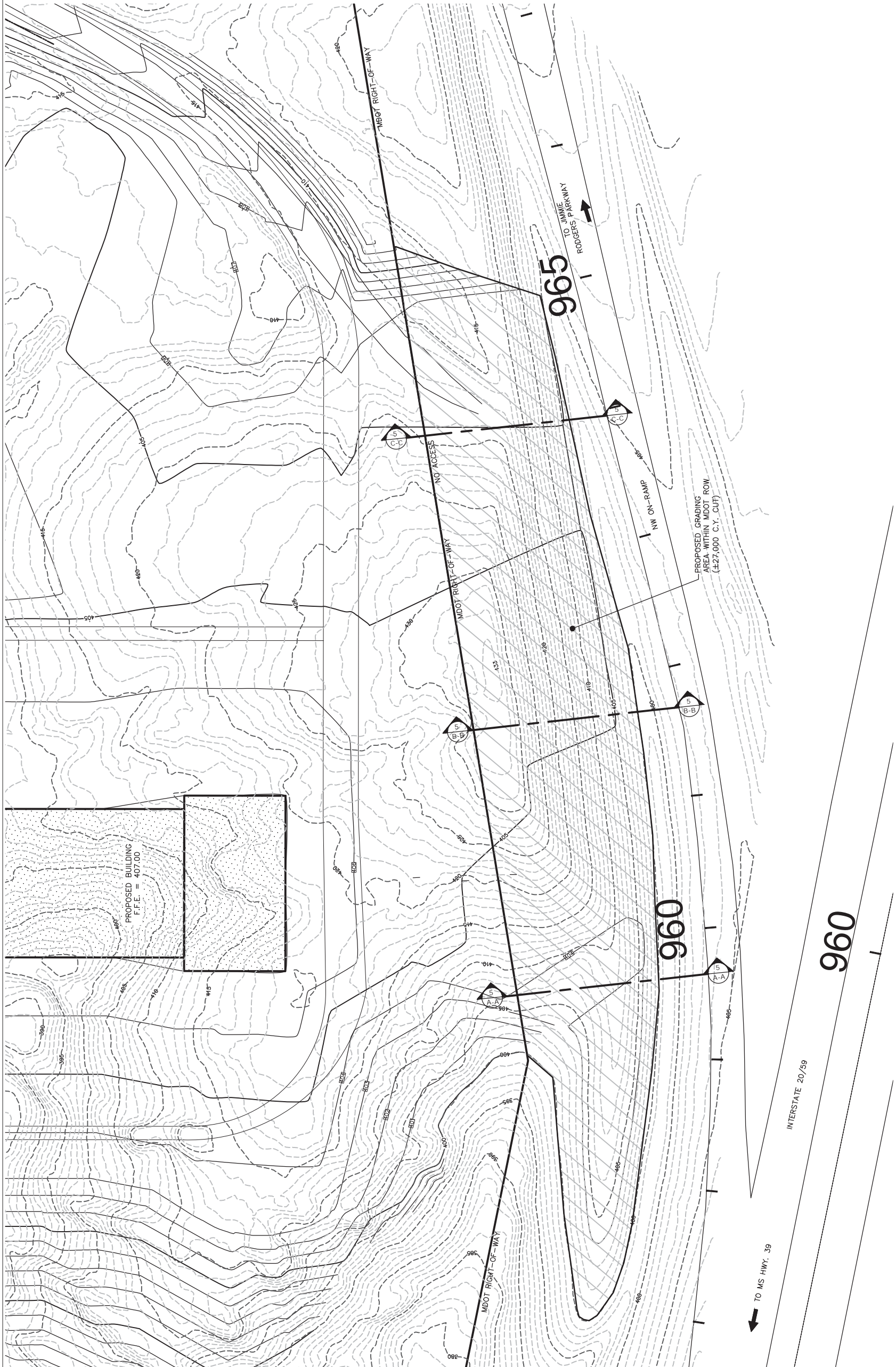

MND-005
Rev. 2-93

MISSISSIPPI DEPARTMENT OF TRANSPORTATION

Supplement to:
MND-001
MND-002
MND-004

Sheet No.: 5 of 11

Permit No.: _____

REVISIONS			
APPLICANT		MDOT	
DATE	BY	DATE	BY

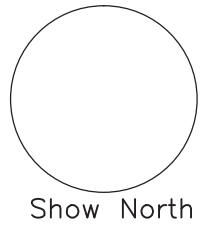

NOTE:

PROPOSED TOTAL EXCAVATION TO BE REMOVED FROM RIGHT-OF-WAY IS ±27,000 C.Y.

STATIONING REFERENCED FROM MDOT PROJECT NO. IMD-0059-03(084) SHEET NO. 59

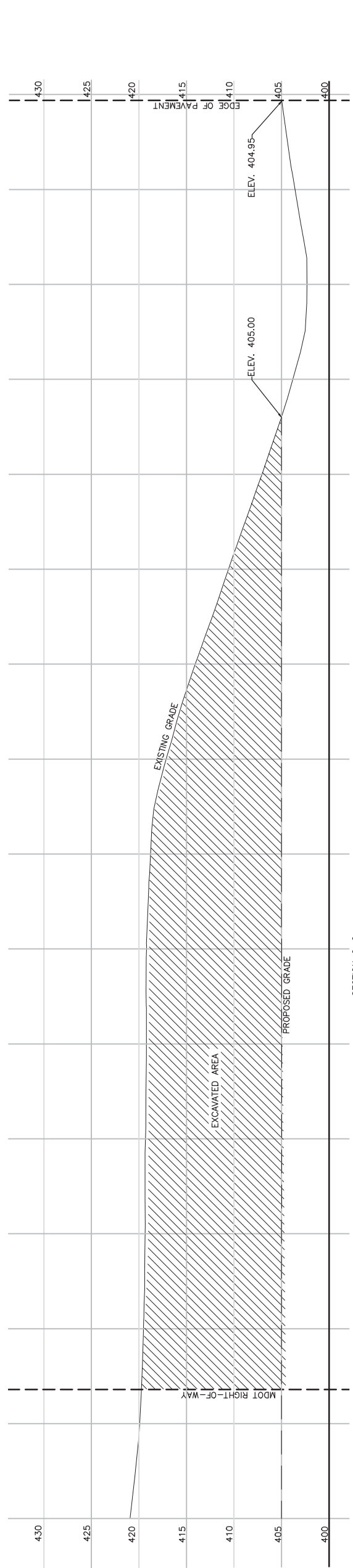
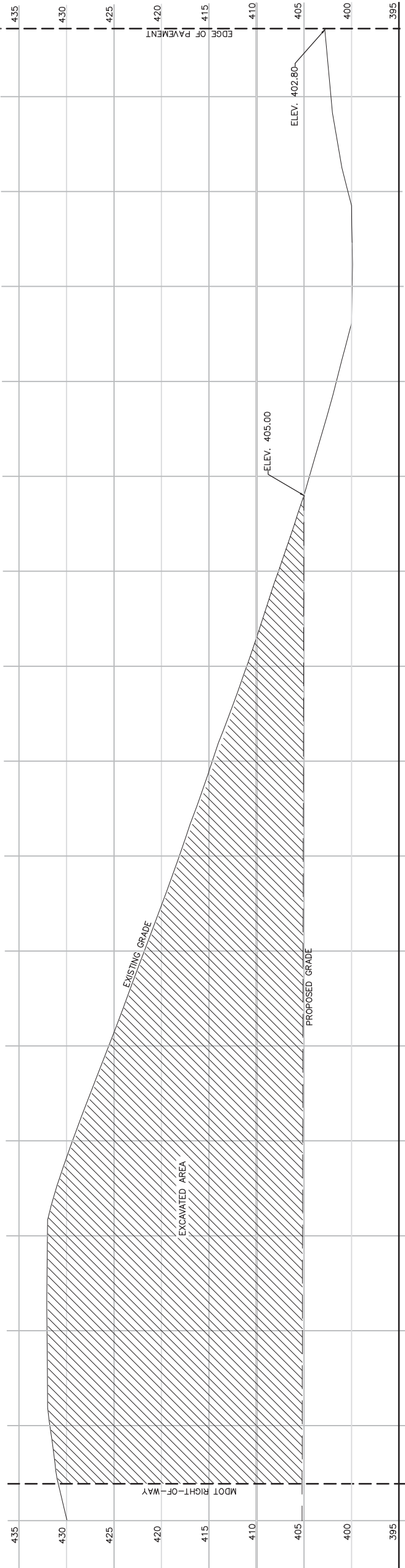
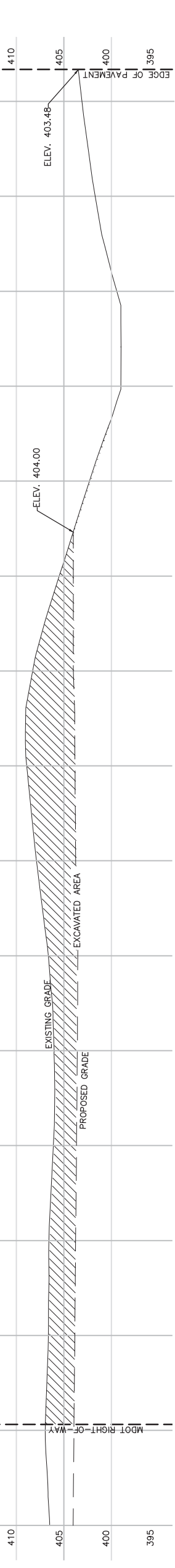

MND-005
Rev. 2-93

MISSISSIPPI DEPARTMENT OF TRANSPORTATION

Supplement to:
MND-001
MND-002
MND-004

Sheet No.: 6 of 11

Permit No.: _____

REVISIONS			
APPLICANT		MDOT	
DATE	BY	DATE	BY



NOTE:

CONTRACTOR SHALL REFER TO
EROSION CONTROL
IMPLEMENTATION SCHEDULE FOR
FURTHER REQUIREMENTS



MND-005
Rev. 2-93

MISSISSIPPI DEPARTMENT OF TRANSPORTATION

Supplement to:
MND-001
MND-002
MND-004

Sheet No.: _____ of _____

Permit No.: _____

REVISIONS			
APPLICANT		MDOT	
DATE	BY	DATE	BY

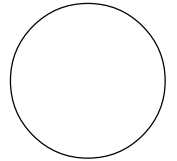

Show North

Call before any work is done, the following:
Michael Lee: 601-683-3341 MDOT Lighting
Amrik Singh: 601-359-1832 MDOT Fiber

Sheet No.: _____ of _____

Permit No.: _____

REVISIONS			
APPLICANT		MDOT	
DATE	BY	DATE	BY

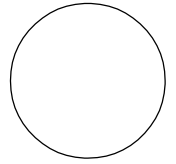

Erosion Control Implementation Schedule

Phase 1: BMPs are to be installed before any major land disturbing activity. Silt fence is to be installed as depicted in the Erosion Control Plan Sheet and along the perimeter of the downstream side of any disturbed areas.

Phase 2: Soil stabilization – vegetative stabilization measures must be initiated whenever any clearing, grading, excavating, or other land disturbing activities have temporarily or permanently ceased on any portion of the site and will not resume for a period of fourteen (14) days or more. The appropriate temporary or permanent vegetative practices shall be implemented immediately. For the purpose of this permit, “immediately” is interpreted to mean no later than the next workday. No more than one “1” acre shall be placed in a disturbed or upset condition until other areas of the project are stabilized.

Phase 3: Upon completion of work, any remaining permanent erosion control measures will be installed and any required permanent grassing will be finished. See *Permanent Grassing Schedule*.

Refer to attached MDOT standard drawings for details on installation.

VEGETATION SCHEDULE

All soil preparation, fertilizing, sprigging, seeding, and work applied to same shall be in accordance with the following procedure and schedule.

- SHAPE AREA:** Shape all areas to typical cross-section and dress same as required by the permit.
- SPREAD FERTILIZER AND PREPARE SEED BED:** The required fertilizer and agricultural limestone shall be spread uniformly over the area to be top seeded. After the fertilizer and limestone has been spread, the area shall be thoroughly pulverized, and the fertilizer incorporated in the top four (4) inches of the graded areas.
- KIND AND QUANTITY OF FERTILIZER.** Fertilizer and agricultural limestone shall be applied at the following rates.
Combination fertilizer - 13-13-13 - 800 lbs. per acre
Agricultural limestone - - 2 tons per acre
- SEEDING AND/OR SODDING.** Seeding and/or sodding is required on disturbed areas specified in the permit or by a representative of the Department. All areas should receive the seeding as follows:
Permanent Grassing Schedule
Common Bermuda - 15 lbs. per acre- year round
Bahia - 30 lbs. per acre - year round
Fescue (KY.31) - 15 lbs. per acre – August 1- April 1
Crimson Clover - 15 lbs. per acre – August 1- April 1
Temporary Grassing Schedule
Rye Grass - 25 lbs. per acre – September 1 - March 31
Oats - 90 lbs. per acre – September 1 – December 15

MND-005

REV. 2-93

MISSISSIPPI DEPARTMENT OF TRANSPORTATION

SUPPLEMENT TO:

MND-001
MND-002
MND-004

SHEET NO. _____ OF _____

PERMIT NO. _____

REVISIONS			
APPLICANT		MDOT	
DATE	BY	DATE	BY

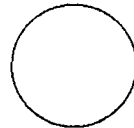

SHOW NORTH

2/22/2014 10:41:52 AM ECD-3.dwg

Project: 59-0446
Title: Silt Fence Details
Author: [unreadable]

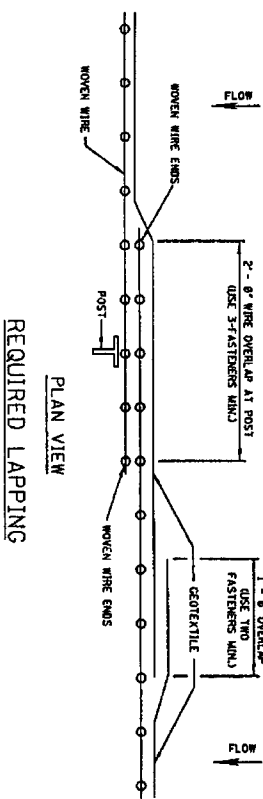

REQUIRED LAPPING
PLAN VIEW

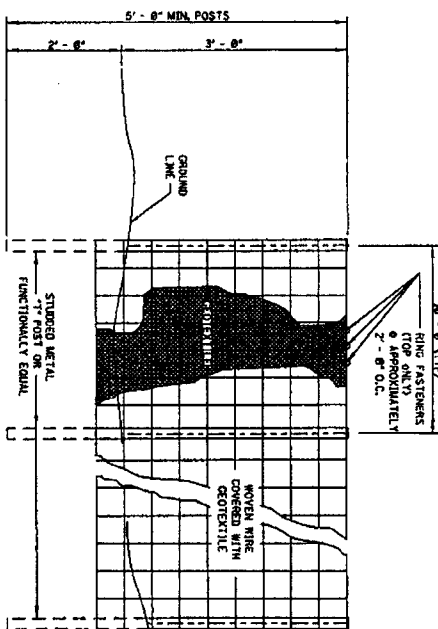

ELEVATION VIEW

- NOTES:
- SILT FENCES SHALL BE USED IN AREAS WHERE FLOW IS NOT SEVERE.
 - SILT FENCES ARE TEMPORARY SEDIMENT CONTROL FENCES THAT SHALL BE DELETED UPON THE COMPLETION OF THE PROJECT.
 - POSITIVE SLOPING AREAS SHOULD BE BUILT ON A SLOPE OF 3:1 OR GREATER.
 - SILT FENCES SHOULD BE PLACED INSIDE RIGHT-OF-WAY AND ALONG EDGE OF CLEARING LIMITS. THIS WILL ALLOW ROOM FOR A BACK-UP FENCE IF FIRST FENCE BECOMES FULL.
 - WHenever possible silt fence shall be constructed across a level area in the direction of flow.
 - THE CONSTRUCTION MAY ELECT TO USE EITHER METHOD I OR METHOD II.
 - COST TO BE LINEAR FEET OF SILT FENCE.
 - METHOD II INSTALLATION SHALL BE ACCOMPLISHED USING AN IMPLEMENT THAT IS MANUFACTURED FOR THE APPLICATION AND PROVIDES A COMPENSATION MEETING THE REQUIREMENTS OF THE DETAIL.
 - POSTS SHALL BE SPACED AT 5' ON CENTER.
 - POSTS SHALL BE 5/8" DIA. AND SHALL HAVE A MINIMUM OF 6 LINE WIRES WITH 3/8" DIA. SPACING OF 32" IN WIDTH AND SHALL HAVE A MINIMUM OF 6 LINE WIRES.
 - GEOTEXTILE FABRIC MEETING THE TYPE II MATERIAL REQUIREMENTS AND INSTALLED ACCORDING TO SPECIFICATION MAY BE USED WITHOUT WIRE FENCE.

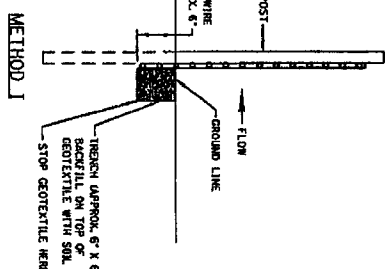

SIDE VIEW

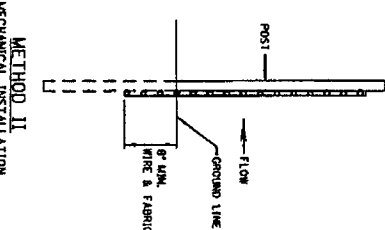

METHOD II MECHANICAL INSTALLATION

MISSISSIPPI DEPARTMENT OF TRANSPORTATION
DETAILS OF SILT FENCE
INSTALLATION

DATE: 2/22/2014
FILE NAME: EROSION CONTROL (ECD-3).DWG
PROJECT: 59-0446

WORKING NUMBER
ECD-3
SHEET NUMBER

STATE	PROJECT NO.
MISS	

MND-005

REV. 2-93

MISSISSIPPI DEPARTMENT OF TRANSPORTATION

SUPPLEMENT TO:

MND-001
MND-002
MND-004

SHEET NO. _____ OF _____

PERMIT NO. _____

REVISIONS			
APPLICANT		MOOT	
DATE	BY	DATE	BY

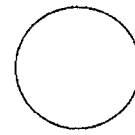

SHOW NORTH

0/28/2014 15:51:32 ECU-5.DWG

WATTLE DITCH CHECK SELECTION GUIDELINES

WATTLE DITCH CHECKS ARE APPROPRIATE FOR VELOCITY REDUCTION AND CONTROL OF SEDIMENT TRANSPORT UNDER LOW TO MEDIUM FLOW CONDITIONS.

ELEVATION DETAIL

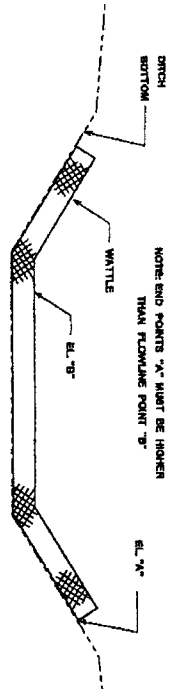

NOTE: END POINTS 'A' MUST BE HIGHER THAN FLOWLINE POINT 'B'.

DETAIL (DITCH CHECK)

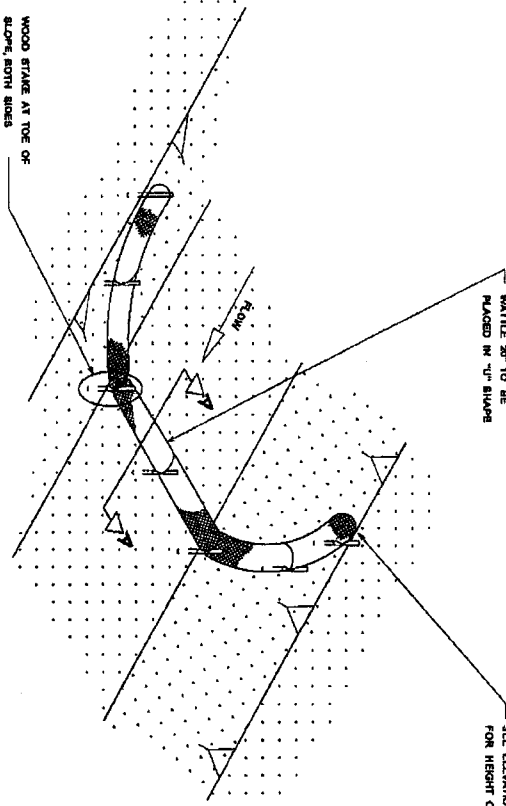

SECTION A-A

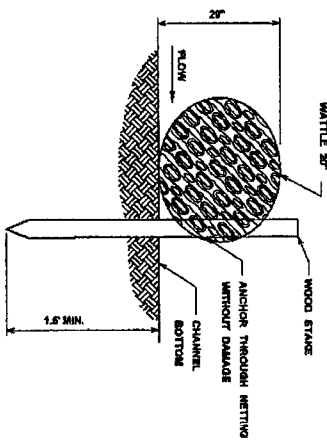

- NOTES:
1. MINIMUM RECOMMENDED PLACEMENT INTERVAL BETWEEN WATTLE DITCH CHECK IS 400 FEET UNLESS SHOWN OTHERWISE ON THE PLAN OR EROSION CONTROL PLAN APPROVED BY THE ENGINEER. SEE SPACING GUIDANCE ON ECD-4.
 2. ANCHORING WOOD STAKES SHALL BE SIZED, SPACED, DOWNED, AND SET OF A MATERIAL THAT SPECIFICALLY SECURES THE CHECK STAKE SPACING SHALL BE A MAXIMUM OF THREE FEET. ALL NON-APPROPRIATE MATERIALS SHALL BE REMOVED WHEN NO LONGER NEEDED.
 3. TRENCHING OF WATTLES MAY BE NECESSARY IF PILING BECOMES EVIDENT.
 4. WATTLES SHOULD NOT BE USED IN HARD BOTTOM CHANNELS.

NO.	REVISION

MISSISSIPPI DEPARTMENT OF TRANSPORTATION
DETAILS OF EROSION CONTROL
WATTLE DITCH CHECK

FILE NAME: EROSION CONTROL - WATTLE DITCH CHECK.dwg
DATE: 02/28/2014 15:51:32

WORKING NUMBER
ECD-6
SHEET NUMBER

STATE PROJECT NO.
MISS.

Sheet No.: _____ of _____

Permit No.: _____

REVISIONS			
APPLICANT		MDOT	
DATE	BY	DATE	BY

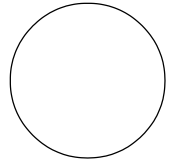

Show North

Applicant agrees to assume full responsibility for safeguarding and directing traffic in accordance with the Manual Uniform Traffic Control Devices (MUTCD) during this work. All signs and traffic control devices are to be removed from roadway when not in use.

In accordance with the Code of Federal Regulations (CFR) Part 23 – Rule – 634.3---

All workers within the right of way of a Federal-aid highway who are exposed either to traffic (vehicles using the highway for purposes of travel) and/or to construction equipment within the work area shall wear high-visibility safety apparel. High-visibility safety apparel is that which meets the Performance Class 3 of ANSI/ISEA 107-2004 "American National Standard for High-Visibility Safety Apparel and Headwear."

All sod disturbed by the proposed work is to be replaced by applicant and maintained for sufficient length of time to ensure a living and growing sod.

The Mississippi Department of Transportation does not purport to grant permission for, or to become party to, any work that will change the flow of existing water on or off State property or to change the disposition of flood waters.

It is understood and agreed that any encroachments on adjoining property owners will be secured with easements from said property owners.

As a condition for the approval of this permit application, the applicant agrees to perform work as shown on the application, make any necessary repairs of damages to the right-of-way, roadway slopes, shoulders, or pavement, all to the satisfaction of the Department of Transportation Commission and to save the Commission harmless as to all claims arising from work performed under this permit.

As a condition for the approval of this application, applicant will be responsible for keeping the roadway clear of mud or any other debris caused by this operation. The applicant will be required to pay any cost incurred by MS. Department of Transportation in having to remove mud or debris from the highway as a result of this operation.

The applicant agrees to assume the responsibility for obtaining any and all necessary permits from any other regulating entity prior to beginning any work on state maintained right of way. This can include entities such as but not limited to the municipality, county, MS State Department of Environmental Quality (DEQ) and the United States Corps of Engineers.

CALL MISSISSIPPI 811 BEFORE ANY WORK STARTS

Best Management Standards

Construction-Exit Pad (CEP)



Practice Description

A construction-exit pad is a stone-base pad designed to provide a buffer area where mud- and caked-soil can be removed from the tires of construction vehicles to avoid transporting it onto public roads. This practice applies anywhere traffic will be leaving a construction site and moving directly onto a public road or street.

Planning Considerations

Roads and streets adjacent to construction sites should be kept clean for the general safety and welfare of the public. A construction-exit pad (Figure CEP-1) should be provided where mud can be removed from construction vehicle tires before they enter a public road.

If the action of the vehicle traveling over the gravel pad does not sufficiently remove the mud, or if the site is in a particularly sensitive area, a washing facility should be included with the pad (Figure CEP-2). When a washing facility is required, all wash water shall be diverted into a sediment trap or basin.

If the construction-exit pad is located in an area with soils that will not support traffic when wet, a geotextile liner located beneath the aggregate will be required to provide stability to the pad.

Construction of stabilized roads throughout the development site should be considered to lessen the amount of mud transported by vehicular traffic. The construction-exit pad

should be located to provide for maximum use by construction vehicles. Consideration should be given to limiting construction vehicles to only one ingress and egress point. Measures may be necessary to make existing traffic use the construction-exit pad.

Design Criteria and Construction

Site Preparation

Remove all vegetation and other unsuitable material from the foundation area.

Grading

Grade and crown the area for positive drainage. Utilize a diversion to direct any surface flow away from the construction-exit pad. Any runoff from the pad should be diverted into a sediment trap or basin. Install a pipe under the pad, if needed, to maintain drainage ditches along public roads.

Aggregate Size

Aggregate should be Mississippi Department of Transportation Size 1 Stabilizer. Aggregate surface shall be left smooth and sloped for drainage.

Pad Dimensions

The exit pad shall have a minimum aggregate thickness of 6". The exit pad must be a minimum of 50 feet long and shall provide for entering and parking the longest construction vehicles anticipated. MDOT Drawing ECD-15 provides an example of a stabilized construction entrance. The exit pad shall have a typical width of 20 feet, but may be narrower or wider to equal the full width of the vehicular egress.

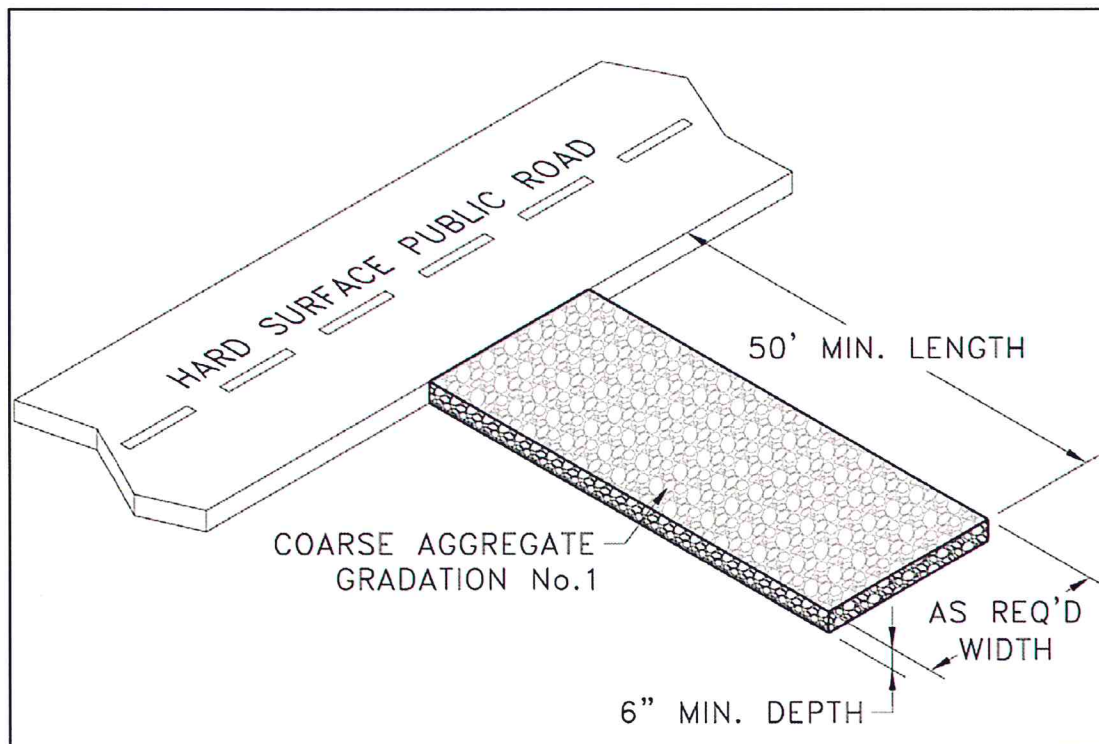

Figure CEP-1 Gravel Construction Exit

Geotextiles

A non-woven geotextile meeting the requirements shown in the table below for Class IV geotextiles should be used under the rock when the subgrade is soft or the blow count is less than 10.

Table CEP-1 Requirements for Nonwoven Geotextile

Property	Test method	Class I	Class II	Class III	Class IV ¹
Tensile strength (lb) ²	ASTM D 4632 grab test	180 minimum	120 minimum	90 minimum	115 minimum
Elongation at failure (%) ²	ASTM D 4632	≥ 50	≥ 50	≥ 50	≥ 50
Puncture (pounds)	ASTM D 4833	80 minimum	60 minimum	40 minimum	40 minimum
Ultraviolet light (% residual tensile strength)	ASTM D 4355 150-hr exposure	70 minimum	70 minimum	70 minimum	70 minimum
Apparent opening size (AOS)	ASTM D 4751	As specified max. #40 ³	As specified max. #40 ³	As specified max. #40 ³	As specified max. #40 ³
Permittivity sec ⁻¹	ASTM D 4491	0.70 minimum	0.70 minimum	0.70 minimum	0.10 minimum

Table copied from NRCS Material Specification 592.

- ¹ Heat-bonded or resin-bonded geotextile may be used for classes III and IV. They are particularly well suited to class IV. Needle-punched geotextile required for all other classes.
- ² Minimum average roll value (weakest principal direction).
- ³ U.S. standard sieve size.

Washing

A washing facility shall be provided, if necessary, to prevent mud- and caked-soil from being transported to public streets and highways. It shall be constructed of concrete, stone, and/or other durable materials. Provisions shall be provided for the mud and other material to be carried away from the washing facility into a sediment trap or basin to allow for settlement of the sediment from the runoff before it is released from the site.

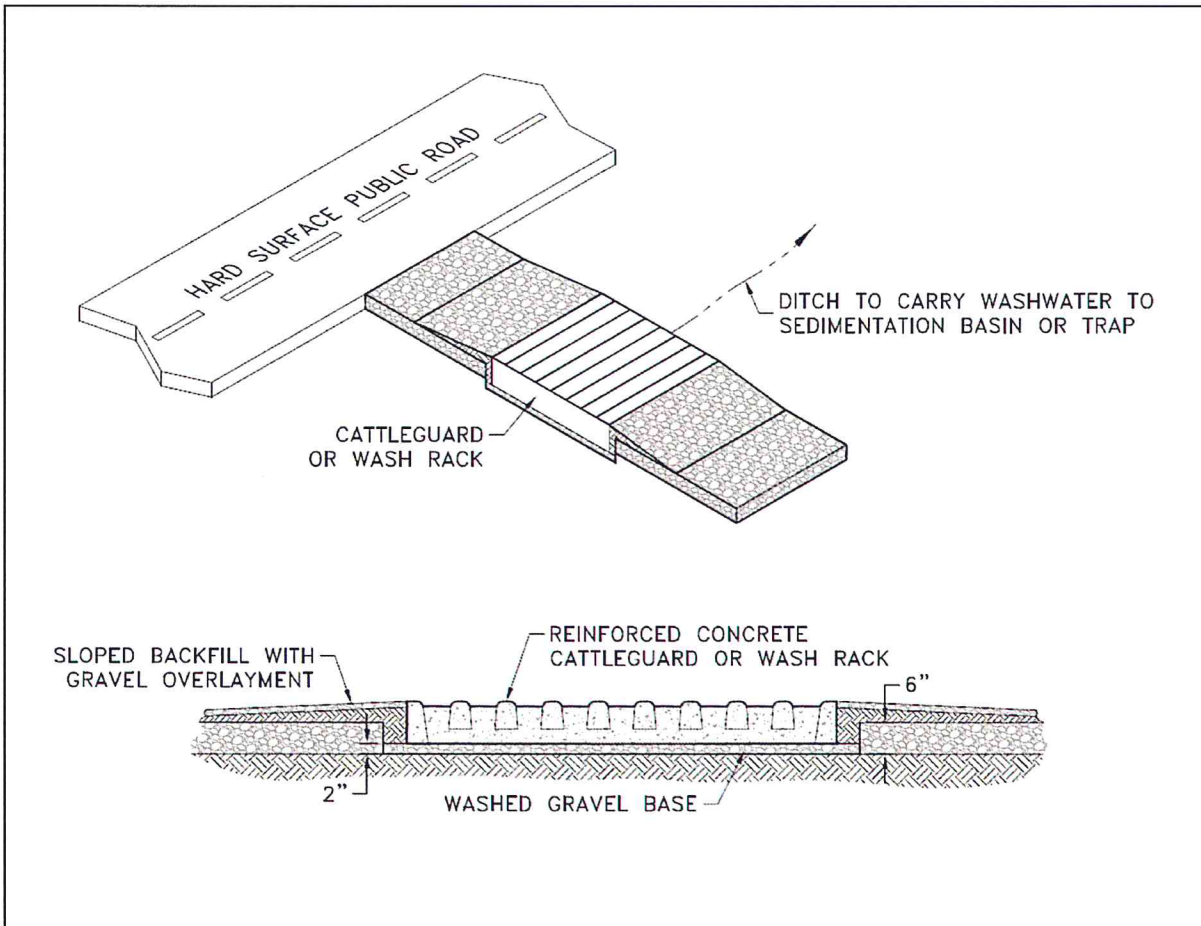

Figure CEP-2 Construction Exit with Wash Rack

Common Problems

Consult with a qualified design professional if any of the following occur:

Inadequate runoff control and sediment washes onto public road: install diversions or other runoff-control measures.

Ruts and muddy conditions develop as stone are pressed into soil: increase stone size or pad thickness, or add geotextile fabric.

Pad too short for heavy-construction traffic: consult design professional about extending pad to the necessary length

Maintenance

Remove large chunks of mud- or caked-soil from construction-exit pad daily to minimize sediment buildup.

Inspect stone pad and sediment-disposal area weekly and after storm events or heavy use.

Reshape pad as needed for drainage and runoff control.

Top-dress with clean-specified stone as needed to maintain effectiveness of the practice.

Immediately remove mud or sediment tracked or washed onto public road.

Repair any broken-road pavement immediately.

Remove unneeded exit-pad materials from areas where permanent vegetation will be established.

References

BMPs from Volume 1

Chapter 4

Construction Phasing/Sequencing (CPS)	4-3
Land Grading (LG)	4-16
Housekeeping (HK)	4-43
Preservation of Vegetation (PV)	4-64

MDOT Drawings Referenced

ECD-15 Stabilized Construction Entrance	4-11
---	------

Check Dam (CD)



Practice Description

A check dam is a small barrier or dam constructed across a swale, drainage ditch or other area of concentrated flow for the purpose of reducing channel erosion. Channel erosion is reduced because check dams flatten the gradient of the flow channel and slow the velocity of channel flow. Most check dams are constructed of rock, but hay bales, logs and other materials may be acceptable. Contrary to popular opinion, most check dams trap an insignificant volume of sediment.

This practice applies in small open channels and drainageways, including temporary and permanent swales. It is not to be used in a live stream. Situations of use include areas in need of protection during establishment of grass and areas that cannot receive a temporary or permanent non-erodible lining for an extended period of time.

Planning Considerations

Check dams are used in concentrated flow areas to provide temporary channel stabilization during the intense runoff periods associated with construction disturbances. Check dams may be constructed of rock, logs, hay bales or other suitable material, including manufactured products. MDOT Drawing ECD-4 at the end of this practice shows the typical application of check dam structures. Most check dams are constructed of rock. Rock may not be acceptable in some installations because of aesthetics; therefore, alternative types of check dams need to be considered.

Rock check dams

Rock check dams (Figures CD-1 and CD-2) are usually installed with backhoes or other suitable equipment, but hand labor is likely needed to complete most installations to the quality needed. The rock is usually purchased, and some locations in the state may not have rock readily available. The use of rock should be considered carefully in areas to be

mowed. Some rock may be washed away during heavy rain events and should be removed before each mowing operation. Additional installation drawings are provided at the end of this practice as MDOT Drawings ECD-8 and ECD-9.

Log check dams

Log check dams (Figure CD-3) are more economical from a materials cost standpoint since logs can usually be salvaged from clearing operations. The time and labor required would be greater for log check dams. Increased labor costs would offset the reduced material costs. Log check dams would not be permanent but may last long enough to get grass linings established.

Hay bale check dams

Check dams constructed of hay bales (Figure CD-4) have the shortest life of the materials discussed and are only used as a temporary means to help establish a channel to vegetation. MDOT Drawing ECD-5 is provided at the end of this practice and shows more specifics for hay bale check dams. MDOT Drawing ECD-6 shows typical details for a straw wattle ditch check as an alternative to hay bale check dams. Hay bale check dams should not be used where permanent watercourse protection is needed and should be used only in concentrated-flow areas where only minimal runoff occurs.

Without proper installation, which is rarely done, hay bale check dams always fail.

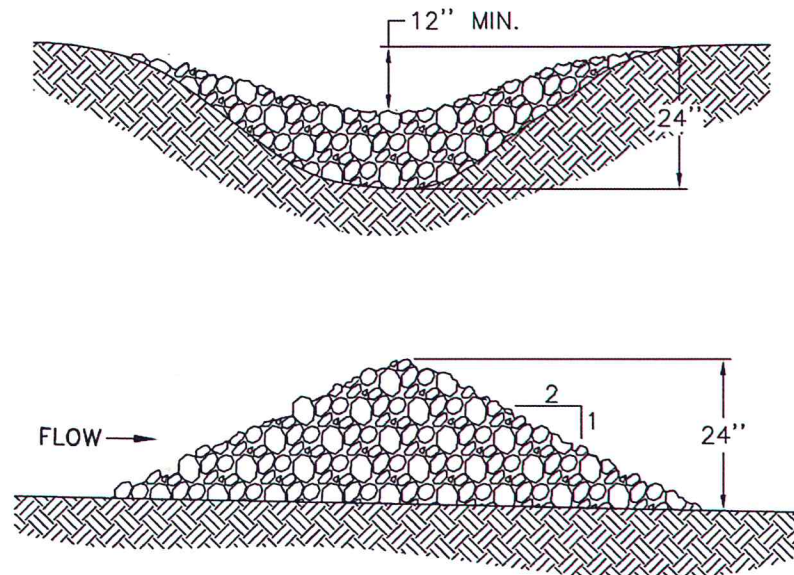

Figure CD-1 Profile of Typical Rock Check Dams

Check dams should be planned to be compatible with the other features such as streets, walks, trails, sediment basins and rights-of-way or property lines. Check dams are normally constructed in series, and the dams should be located at a normal interval from other grade controls such as culverts or sediment basins.

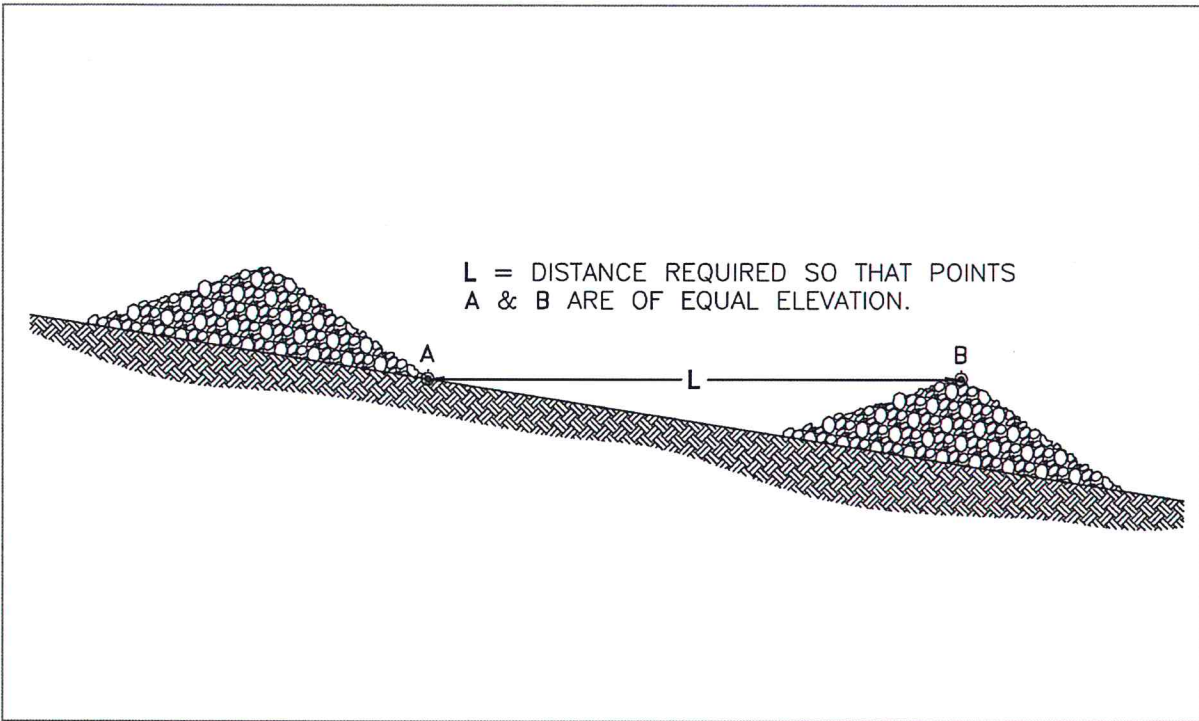

Figure CD-2 Cross Section of Typical Rock Check Dam

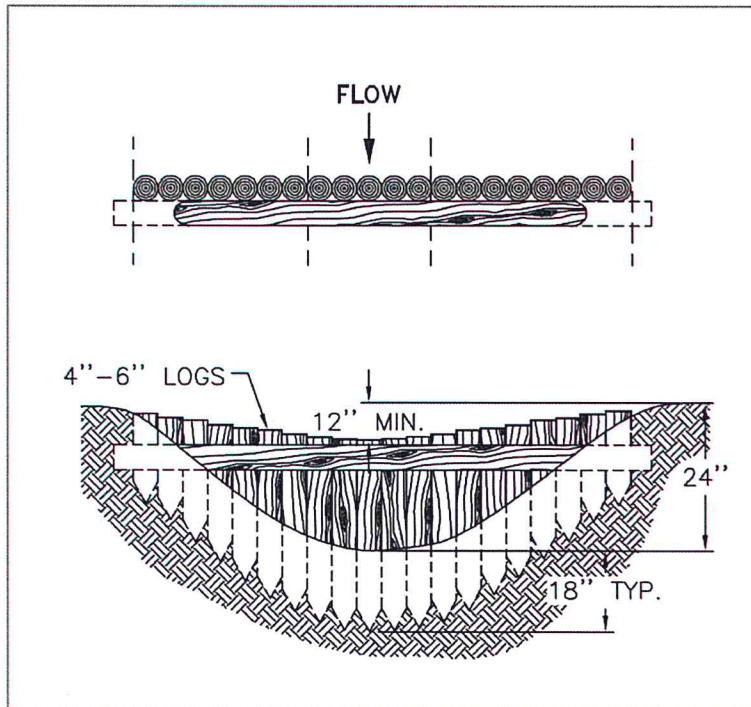

Figure CD-3 Typical Log Check Dam

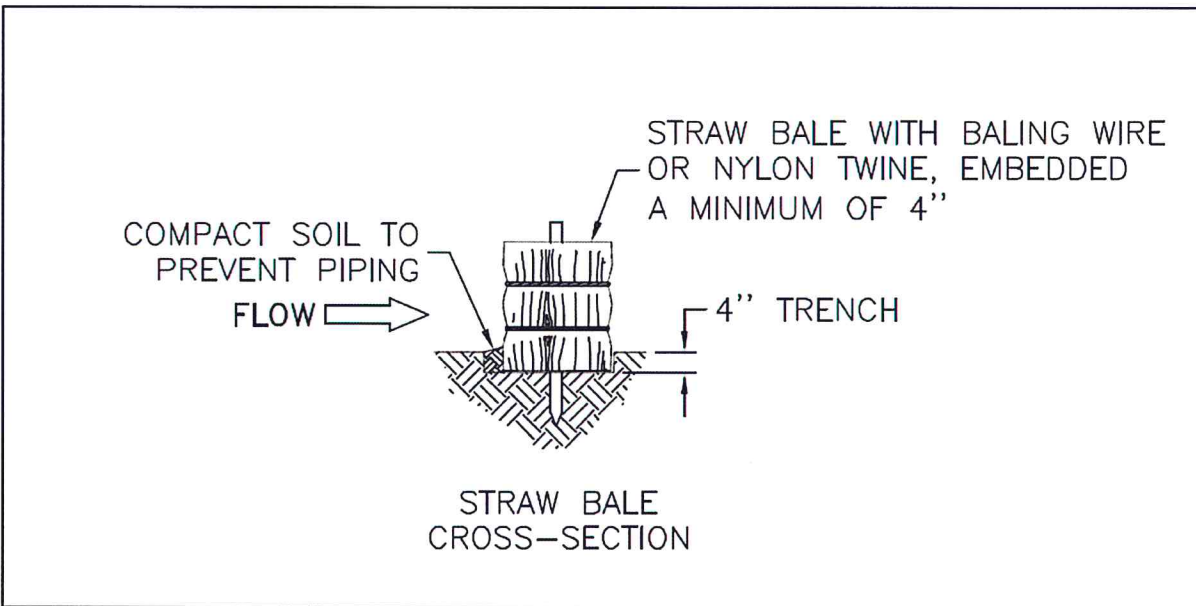

Figure CD-4 Typical Hay Bale Check Dam
(NOTE: Without proper installation, which is rarely done, hay bale check dams always fail.)

Design Criteria and Installation

Formal design is not required. The following limiting factors should be adhered to when designing check dams.

Drainage Area

Ten acres or less (rock or logs).

Maximum Height

Two feet when drainage area is less than 5 acres.

Three feet when drainage area is 5 to 10 acres.

Depth of Flow

Six inches when drainage area is less than 5 acres.

Twelve inches when drainage area is 5 to 10 acres.

The top of dam, perpendicular to flow, should be parabolic. The center of the dam should be constructed lower than the ends. The elevation of the center of the dam should be lower than the ends by the depth of flow listed above.

Side Slopes

2:1 or flatter.

Spacing

Elevation of the toe of the upstream dam is at or below elevation of the crest of the downstream dam.

Keyway

The rock or log check dam should be keyed into the channel bottom and abutments to a depth of 12 to 24". The keyway width should be at least 12". The keyway is to prevent erosion around the end of and beneath the dam. Hay bale check dams should be embedded into the soil at least 3".

Rock Check Dams

Rock check dams should be constructed of durable rock riprap. Rock material diameter should be 2" to 15".

In soils where failure by piping of soils into the rock is likely, a geotextile will be used as a filter to separate the soils from the rock. Geotextile should conform to the requirements of type I geotextile in Table CD-1.

Table CD-1 Requirements for Nonwoven Geotextile

Property	Test method	Class I	Class II	Class III	Class IV ¹
Tensile strength (lb) ²	ASTM D 4632 grab test	180 minimum	120 minimum	90 minimum	115 minimum
Elongation at failure (%) ²	ASTM D 4632	≥ 50	≥ 50	≥ 50	≥ 50
Puncture (pounds)	ASTM D 4833	80 minimum	60 minimum	40 minimum	40 minimum
Ultraviolet light (% residual tensile strength)	ASTM D 4355 150-hr exposure	70 minimum	70 minimum	70 minimum	70 minimum
Apparent opening size (AOS)	ASTM D 4751	As specified max. no. 40 ³	As specified max. no. 40 ³	As specified max. no. 40 ³	As specified max. no. 40 ³
Permittivity sec ⁻¹	ASTM D 4491	0.70 minimum	0.70 minimum	0.70 minimum	0.10 minimum

Table copied from NRCS Material Specification 592.

1 Heat-bonded or resin-bonded geotextile may be used for Classes III and IV. They are particularly well suited to Class IV. Needle-punched geotextile is required for all other classes.

2 Minimum average roll value (weakest principal direction).

3 U.S. standard sieve size.

Site Preparation

Determine location of any underground utilities.

Locate and mark the site for each check dam in strategic locations (to avoid utilities and optimize effectiveness of each structure in flattening channel grade).

Remove debris and other unsuitable material that would interfere with proper placement of the check dam materials.

Excavate a shallow keyway (12"-24" deep and at least 12" wide) across the channel and into each abutment for each check dam.

Materials Installation

As specified, install a non-woven geotextile fabric in the keyway in sandy or silty soils. This may not be required in clayey soils.

Construct the dam with a minimum 2:1 side slope over the keyway and securely embed the dam into the channel banks. Position rock to form a parabolic top, perpendicular to channel flow, with the center portion at the elevation shown in the design so that the flow goes over the structure and not around the structure.

Erosion and Sediment Control

Install vegetation (temporary or permanent seeding) or mulching to stabilize other areas disturbed during the construction activities.

Construction Verification

Check finished size, grade and shape for compliance with standard drawings and materials list (check for compliance with specifications if included in contract specifications).

Common Problems

Consult with a qualified design professional if any of the following occur:

Variations in topography on site indicate check dam will not function as intended. Change in plan will be needed.

Materials specified in the plan are not available.

Maintenance

Inspect the check dam for rock displacement and abutments for erosion around the ends of the dam after each significant rainfall event. If the rock appears too small, add additional stone and use a larger size.

Inspect the channel after each significant rainfall event. If channel erosion exceeds expectations, consult with the design professional and consider adding another check dam to reduce channel flow grade.

Sediment should be removed if it reaches a depth of ½ the original dam height. If the area behind the dam fills with sediment, there is a greater likelihood that water will flow around the end of the check dam and cause the practice to fail.

Check dams may be removed when their useful life has been completed. The area where check dams are removed should be seeded and mulched immediately unless a different treatment is prescribed. In some instances check dams should be left as a permanent measure to support channel stability.

References

BMPs from Volume 1

Chapter 4

Temporary Seeding (TS) 4-103

MDOT Drawing ECD-4

Ditch Check Structures, Typical Applications and Details 4-124

MDOT Drawing ECD-5

Temporary Erosion, Sediment and Water Pollution Control Measures, Silt Fence and Hay Bale Ditch Check 4-125

MDOT Drawing ECD-6

Details of Erosion Control Wattle Ditch Check 4-126

MDOT Drawing ECD-7

Details of Erosion Control Silt Dike Ditch Check 4-127

MDOT Drawing ECD-8

Rock Ditch Check 4-128

MDOT Drawing ECD-9

Rock Ditch Check with Sump Excavation 4-129

MDOT Drawing ECD-20

Details of Erosion Control Sandbag Ditch Check 4-130

Sediment Barrier (SB)

SILT FENCE 
 STRAW BALE BARRIER 



Practice Description

Silt fencing is a temporary sediment barrier used across a landscape to reduce the quantity of sediment that is moving farther downslope. Commonly used barriers include silt fence (a geotextile fabric that is trenched into the ground and attached to supporting posts) or hay bales trenched into the ground. Other barrier materials include sand bags, brush piles, and various man-made materials and devices that can be used in a similar manner as silt fence and hay bales.

This practice applies where sheet and rill erosion occurs on small disturbed areas. Barriers intercept runoff from upslope to form ponds that temporarily store runoff and allow sediment to settle out of the water and stay on the construction site.

Planning Considerations

Sediment barriers may be used on developing sites. They should be installed on the contour so that flow will not concentrate and cause bypassing by runoff going around the end of the barrier or overtopping because of lack of storage capacity.

The most commonly used sediment barriers are silt fences, manufactured sediment logs (several names other than “logs” are used), and hay bales. Silt fences and manufactured sediment logs are preferable to hay bales because they are more likely to be installed correctly. The design and installation of a hay bale sediment barrier is the same as for *Straw Bale Sediment Traps*. Manufactured sediment logs should be installed according to manufacturer’s recommendations.

The silt fence is the only sediment barrier covered in this manual.

The success of silt fences depends on a proper installation that causes the fence to develop maximum efficiency of sediment trapping. Silt fences should be carefully installed to meet the intended purpose.

A silt fence is specifically designed to retain sediment transported by sheet flow from disturbed areas, while allowing water to pass through the fence. Silt fences should be installed to be stable under the flows expected from the site. Silt fences should not be installed across streams, ditches, waterways, or other concentrated flow areas.

Silt fences are composed of woven geotextile supported between steel or wooden posts. Silt fences are commercially available with geotextile attached to the post, and can be rolled out and installed by driving the post into the ground. This type of silt fence is simple to install, but more expensive than some other installations. Silt fences must be trenched in at the bottom to prevent runoff from undermining the fence and developing rills under the fence. Locations with high runoff flows or velocities should use wire reinforcement.

Design Criteria

Silt fence installations are normally limited to situations in which only sheet- or overland-flow is expected because they normally cannot pass the volumes of water generated by channel flows. Silt fences are normally constructed of synthetic fabric (woven geotextile), and the life is expected to be the duration of most construction projects. Silt fence fabric should conform to the requirements of Table SB-1.

The drainage area behind the silt fence should not exceed $\frac{1}{4}$ acre per 100 linear feet of silt fence for non-reinforced fence and $\frac{1}{2}$ acre per 100 linear feet of wire-reinforced fence. When all runoff from the drainage area is to be stored behind the fence (i.e. no stormwater disposal system is in place), the maximum slope length behind the fence should not exceed the value shown in Table SB-2.

Type A Silt Fence

The Type A fence is 36" wide with wire reinforcement and is used on sites needing the highest degree of protection by a silt fence. The wire reinforcement is necessary because the Type A silt fence is used for the highest flow situations and has almost 3 times the flow rate as the Type B silt fence. Type A silt fence should be used where runoff flows or velocities are particularly high or where slopes exceed a vertical height of 10 feet.

Provide a riprap splash pad or other outlet protection device for any point where flow may overtop the sediment fence. Ensure that the maximum height of the fence at a protected, reinforced outlet does not exceed 1 foot and that support post spacing does not exceed 4 feet.

This silt fence should be installed as shown in Figure SB-1. Materials for posts and fasteners are shown in Tables SB-3 and SB-4. Details for overlap of the silt fence and fastener placement are shown in Figure SB-4.

Table SB-1 Specifications for Silt Fence

Specifications	Type A	Type B	Type C
Tensile Strength (Lbs. Min.) ¹ (ASTM D-4632)	Warp – 260 Fill – 100	Warp – 120 Fill – 100	Warp – 120 Fill – 100
Elongation (% Max.) (ASTM D-4632)	40	40	40
AOS (Apparent Opening Size) (Max. Sieve Size) (ASTM D-4751)	No. 30	No. 30	No. 30
Flow Rate (Gal/Min/Sq. Ft.) (GDT-87)	70	25	25
Ultraviolet Stability ² (ASTM D-4632 after 300 hours weathering in accordance with ASTM D-4355)	80	80	80
Bursting Strength (PSI Min.) (ASTM D-3786 Diaphragm Bursting Strength Tester)	175	175	175
Minimum Fabric Width (Inches)	36	36	22

¹ Minimum roll average of five specimens.

² Percent of required initial minimum tensile strength.

Table SB-2 Slope Limitations for Silt Fence

Land Slope (Percent)	Maximum Slope Length Above Fence (Feet)
<2	100
2 to 5	75
5 to 10	50
10 to 20*	25
>20	15

*In areas where the slope is greater than 10%, a flat area length of 10 feet between the toe of the slope to the fence should be provided.

Type B Silt Fence

This 36" wide filter fabric should be used on developments where the life of the project is greater than or equal to 6 months.

This silt fence should be installed as shown in Figure SB-2. Materials for posts and fasteners are shown in Tables SB-3 and SB-4. Details for overlap of the silt fence and fastener placement are shown in Figure SB-4.

Type C Silt Fence

Though only 22" wide, this filter fabric allows the same flow rate as Type B silt fence. Type C silt fence should be limited to use on relatively minor projects, such as residential

home sites or small commercial developments where permanent stabilization will be achieved in less than 6 months.

This silt fence should be installed as shown in Figure SB-3. Materials for posts and fasteners are shown in Tables SB-3 and SB-4. Details for overlap of the silt fence and fastener placement are shown in Figure SB-4.

Table SB-3 Post Size for Silt Fence

	Minimum Length	Type of Post	Size of Post
Type A	4'	Steel	1.3 lb./ft. min.
Type B	4'	Soft Wood	3" diameter or 2 X 4
		Oak	1.5" X 1.5"
		Steel	1.3 lb./ft. min.
Type C	3'	Soft Wood	2" diameter or 2 X 2
		Oak	1" X 1"
		Steel	0.75 lb./ft. min.

Table SB-4 Wood Post Fasteners for Silt Fence

	Gauge	Crown	Legs	Staples/Post
Wire Staples	17 min.	3/4" wide	1/2" long	5 min.
	Gauge	Length	Button Heads	Nail/Post
Nails	14 min.	1"	3/4" long	4 min.

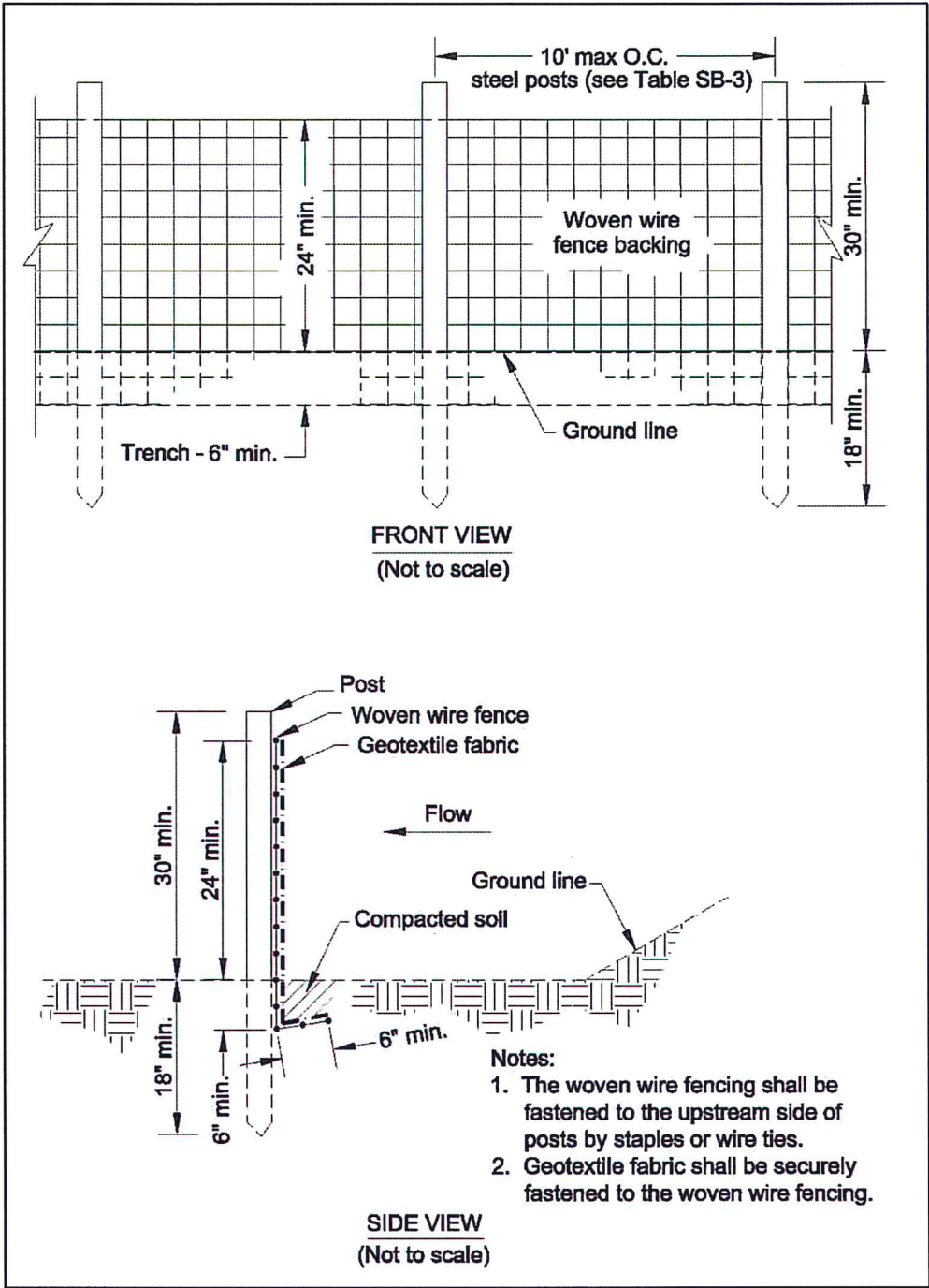

Figure SB-1 Silt Fence-Type A

- (1) For fabric material requirements see Table SB-1
- (2) For post material requirements see Tables SB-3 and SB-4

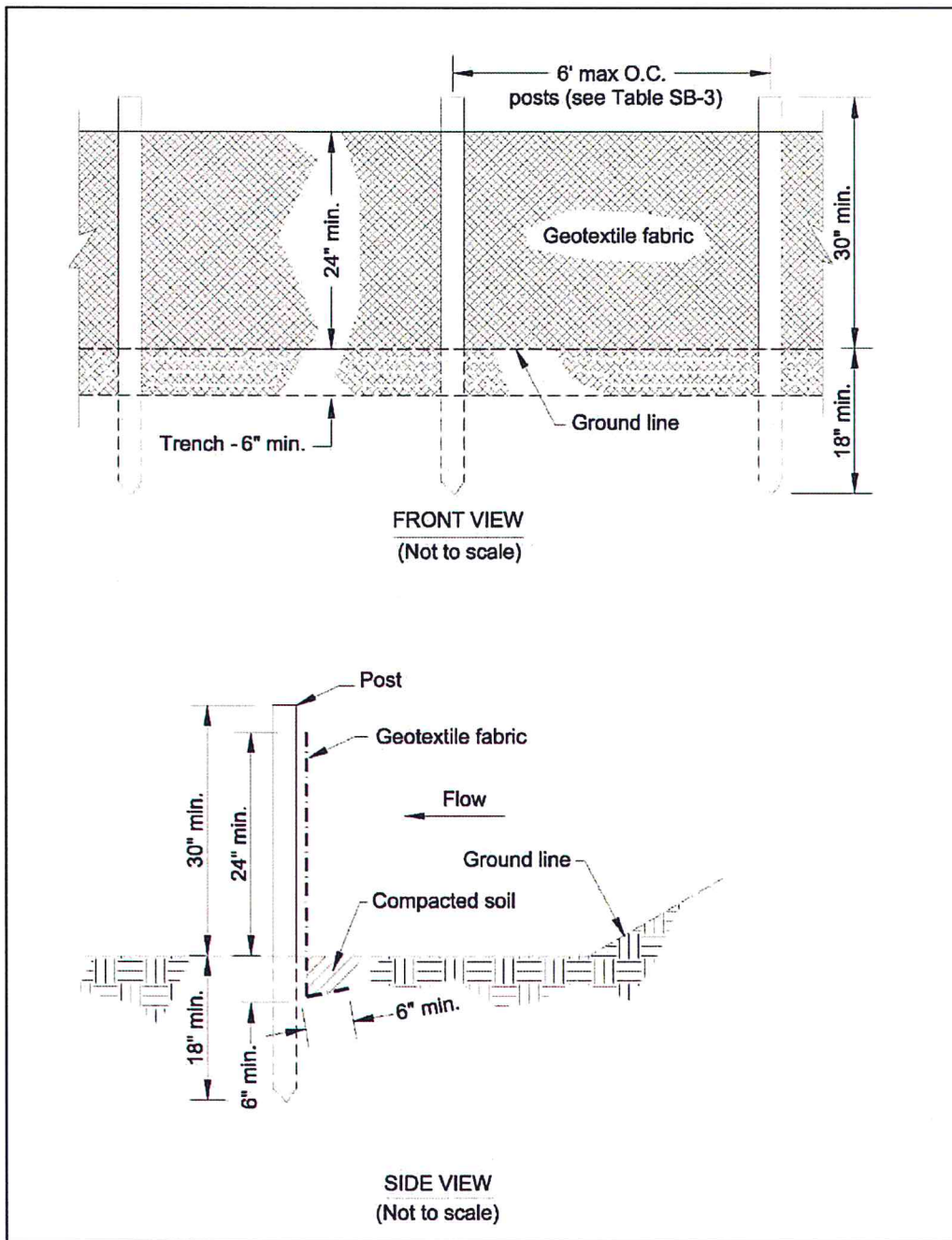

Figure SB-2 Silt Fence - Type B

- (1) For fabric material requirements see Table SB-1
- (2) For post material requirements see Tables SB-3 and SB-4

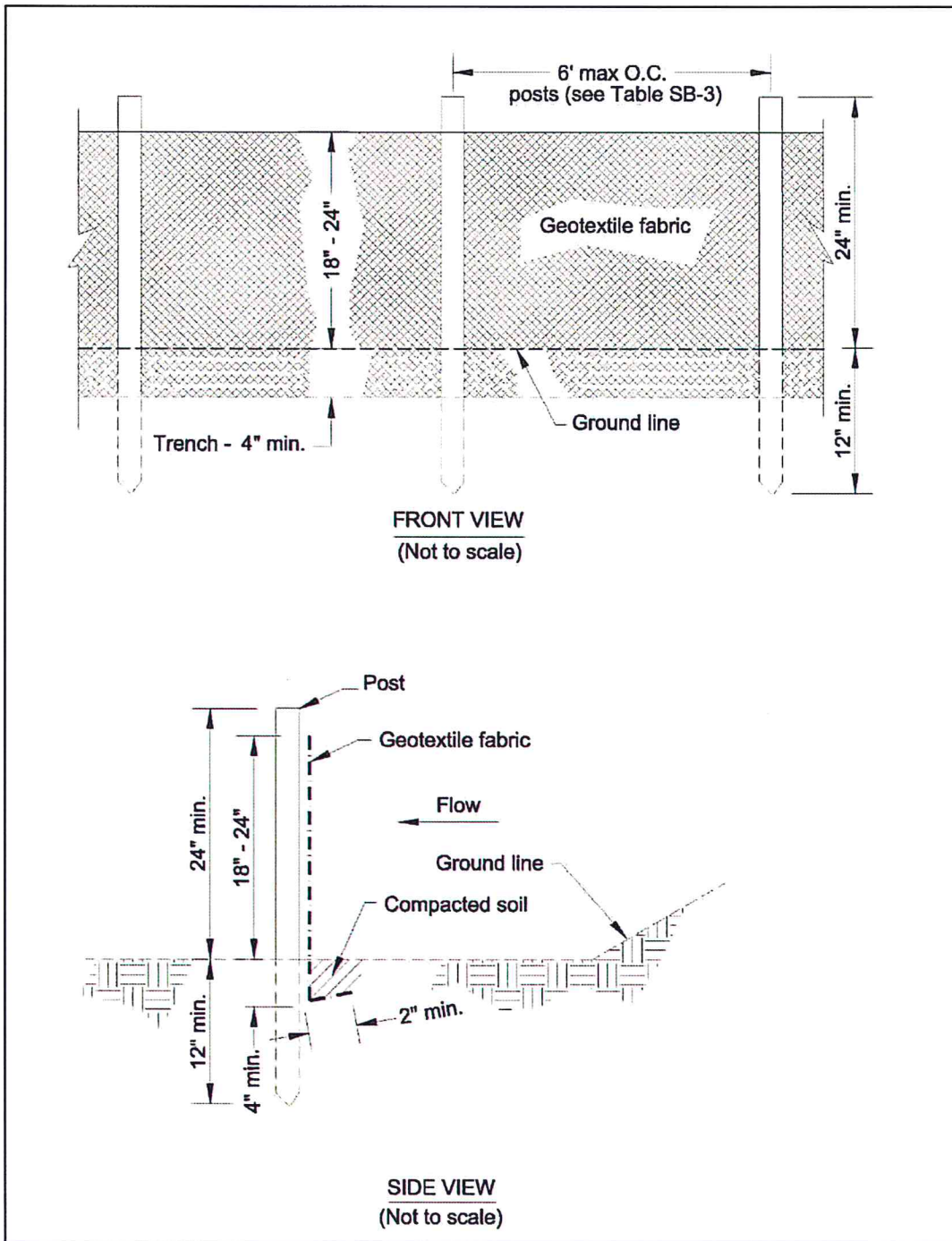

Figure SB-3 Silt Fence – Type C

- (1) For fabric material requirements see Table SB-1
- (2) For post material requirements see Tables SB-3 and SB-4

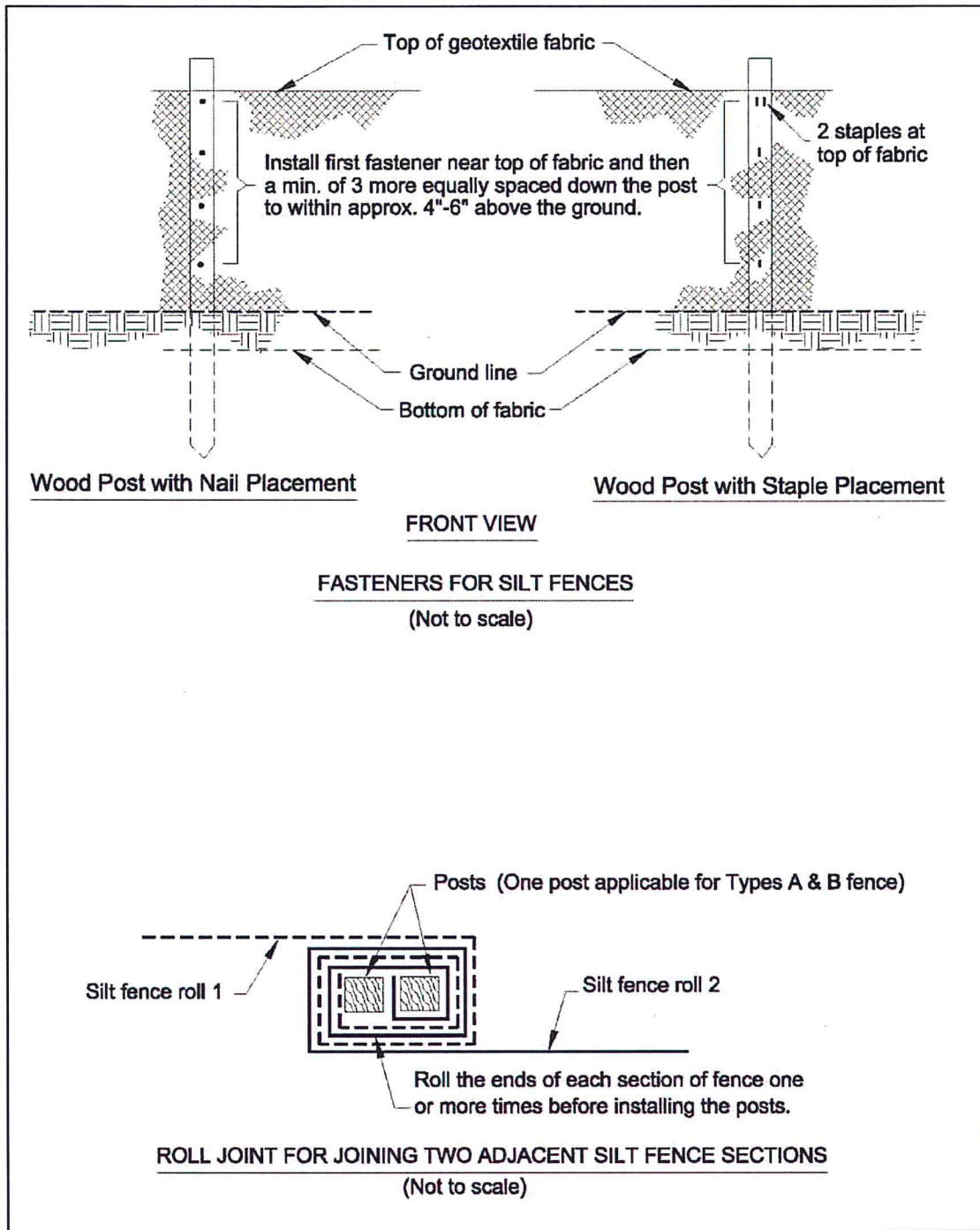

Figure SB-4 Silt Fence Installation Details

Construction

Prior to start of construction, sediment barriers should be designed by a qualified professional. Plans and specifications should be referred to by field personnel throughout the construction process.

Note: Silt fence is the only barrier installation being covered in this handbook.

Site Preparation

Determine exact location of underground utilities so that locations for digging or placement of stakes can be selected where utilities will not be damaged.

Smooth the construction zone to provide a broad, nearly level area for the fence. The area should be wide enough throughout the length of the fence to provide storage of runoff and sediment behind the fence.

Silt Fence Installation

Silt fence should be installed on the contour, so that runoff can be intercepted as sheet flow; ends should be flared uphill to provide temporary storage of water. Silt fence should be placed so that runoff from disturbed areas must pass through the fence. Silt fence should not be placed across concentrated flow areas such as channels or waterways. When placed near the toe of a slope, the fence should be installed far enough from the slope toe to provide a broad, flat area for adequate storage capacity for sediment. Dig a trench at least 6" deep along the fence alignment as shown in Figures SB-1 and SB-2 for Types A & B fences. Type C fences require only a 4" deep trench as shown in Figure SB-3. **Please note that installation with a silt fence installation machine may permit different depths if performance is equal.**

Drive posts at least 18" into the ground on the downslope side of the trench. Space posts a maximum of 10 feet if fence is supported by woven wire, or 6 feet if high-strength fabric and no support fence is used.

Fasten support wire fence to upslope side of posts, extending 6" into the trench, as shown in the appropriate figure for the type fence (see Figure SB-1, SB-2 or SB-3).

Attach a continuous length of fabric to the upslope side of fence posts. Minimize the number of joints and, when necessary to join rolls, they should be joined by rolling the ends together using the "roll joint" method illustrated in Figure SB-4. Avoid joints at low points in the fence line.



For Types A and B silt fence, place the bottom 12" of fabric in the 6" deep (minimum) trench, lapping toward the upslope side. For Type C fabric, place the bottom 6" in the 4" deep (minimum) trench lapping toward the upslope side.

Backfill the trench with compacted earth or gravel as shown in Figures SB-1 – SB-3.

Provide good access in areas of heavy sedimentation for cleanout and maintenance.

Erosion Control

Stabilize disturbed areas in accordance with the vegetation plan. If no vegetation plan exists, consider planting and mulching as a part of barrier installation, and select planting information from the appropriate planting practice (*Permanent Seeding* or *Temporary Seeding*). Select mulching information from the *Mulching Practice*.

Construction Verification

Check finished grades and dimensions of the sediment fence. Check materials for compliance with specifications.

Common Problems

Consult with a qualified design professional if any of the following occurs:

Variations in topography on site indicate sediment fence will not function as intended, or alignment is not on contour, or fence crosses concentrated flow areas; changes in plan may be needed.

Design specifications for filter fabric, support posts, support fence, gravel, or riprap cannot be met; substitutions may be required. Unapproved substitutions could lead to failure.

Drainage area appears to exceed ¼ acre for 100 feet of non-reinforced silt fence and ½ acre for 100 feet for reinforced fence. Additional sediment-control BMPs may be required.

Maintenance

Inspect sediment fences at least once a week and after each significant rain event.

Make required repairs immediately.

Should the fabric of silt fence collapse, tear, decompose, or become ineffective, replace it promptly.

Remove sediment deposits when they reach a depth of 15" or ½ the height of the fence as installed, to provide adequate storage volume for the next rain event and to reduce pressure on the fence.

After the contributing drainage area has been properly stabilized, remove all barrier materials and unstable sediment deposits, bring the area to grade, and stabilize it with vegetation.

References

BMPs from Volume I

Chapter 4

Mulching (MU) 4-48

MDOT Drawing ECD-2

Details of Sediment Barrier Applications 4-295

MDOT Drawing ECD-3

Details of Silt Fence Installation 4-296

MDOT Drawing SSF-1

Super Silt Fence 4-297

Fabric Drop Inlet Protection (FIP)



Practice Description

Fabric drop inlet protection is a structurally supported geotextile barrier placed around or over a drop inlet to prevent sediment from entering storm drains during construction. This practice applies where early use of the storm drain system is necessary prior to stabilization of the disturbed drainage area. This practice is suitable for inlets with a drainage area of less than 1 acre and a gentle approach slope generally of 1% or less.

Planning Considerations

Storm sewers that are made operational before their drainage area is stabilized can convey large amounts of sediment to natural drainage ways. In case of extreme sediment loading, the storm sewer itself may clog and lose a major portion of its capacity. To avoid these problems, it is necessary to prevent sediment from entering the system at the inlets that discharge directly to waters of the state.

The best way to prevent sediment from entering the storm sewer system is to stabilize the site as quickly as possible, preventing erosion and stopping sediment at its source. Sediment is best treated by preventing erosion. Leave as much of the site undisturbed as possible in the total site plan. Clear and disturb the site in small increments, if possible.

Numerous products have been developed to facilitate the capture of suspended soil particles at inlets. The design criteria for performance should be considered when evaluating alternative products. Products that will likely not meet performance goals or that usually fail under storm conditions should not be selected.

Design Criteria and Installation

Prior to start of construction, fabric drop inlet protection structures should be designed by a qualified professional. Plans and specifications should be available to field personnel. *(Note: Premanufactured fabric drop inlet protective structures should be installed and maintained according to the manufacturer's requirements.)*



Drainage Area

Drainage area should be less than 1 acre per inlet.

Sediment Storage

The basin created at the inlet should provide 67 cubic yards per disturbed acre of sediment storage.

Site Preparation

The soil around the drop inlet should be well compacted. The area around the drop inlet should be shaped, if necessary, to store the runoff on an almost level area. If runoff could bypass the protected inlet, a temporary dike should be planned and force the runoff to be trapped by the protective device.

Approach

The approach to the inlet protection practice should generally be less than 1% slope.

Height

The height of the structurally supported geotextile should be at least 1 foot but no more than 2.5 feet. The base of the fabric should be buried with compacted earth fill at least 12 inches into the soil or extend horizontally and be adequately secured with ballast material according to the manufacturer's recommendations. Ensure that the height of the structure when fully ponded does not cause unintentional damage or hazards to adjacent areas.

Structural Frame Installation

The frame (premanufactured or constructed) should provide the internal support necessary to prevent the structure from buckling, the fabric from sagging, or the fabric from being undermined. Frames should be positioned so that water that overtops the device goes directly into the inlet and does not cause erosion between the frame and inlet. Premanufactured frames should be installed according to manufacturer's recommendations.

Fabric Installation

Generally, fabric is installed by one of two methods:

Fabric can be buried vertically in a trench. The trench is excavated at least 12 inches into compacted soil adjacent to the inlet. Support posts are installed securely against the exterior of the drop inlet. Fabric along with wire fence is secured in the bottom of the trench and against the exterior surface of the inlet with stakes no more than 2 feet apart

and driven at least 6 inches into the soil. The trench is backfilled with hand-compacted soil to the density equivalent to the surrounding soil. Fence and fabric are secured to the posts and the structure internally supported to meet the structural requirements of the device.

Fabric for pre-manufactured drop inlet protective devices is generally secured with ballast pockets on well-compacted soil around the inlet. Install these according to manufacturer's recommendations

Performance

Either the system of protection for the project or the drop inlet protection that discharges directly to the outfall of the project must be designed to meet the NTU requirements for discharge.

Stabilization

Stabilize all bare areas that drain to the inlet with temporary seeding and mulching unless construction will disturb it within 13 days.

Safety

Protection should be provided to prevent children from entering open-top structures.

Construction Verification

Check finished grades and dimensions of fabric drop inlet protection structures.

Common Problems

Consult with a qualified design professional if any of the following occurs:

Variations in site conditions indicate that the practice will not function as intended; change in plan may be needed.

Sediment not removed from pool resulting in inadequate storage volume for the next storm.

Top of fabric set too high, resulting in flow bypassing the inlet.

Fabric is not adjacent to the inlet exterior surface, resulting in erosion and undercutting of inlet.

Maintenance

Inspect fabric barrier after each rainfall event and make needed repairs immediately.

Remove sediment from the pool area when sediment has reached ½ the fabric height. Take care not to damage or undercut the fabric during the sediment removal.

When the contributing drainage area has been adequately stabilized, remove all materials and unstable sediment and dispose of properly. Fill the disturbed area to the grade of the drop inlet. Stabilize disturbed areas in accordance with the plans.

References

BMPs from Volume 1

Chapter 4

Sediment Barrier (SB) 4-284

Sediment Basin (SBN) 4-298

MDOT Drawing ECD-3

Details of Silt Fence Installation 4-247

MDOT Drawing ECD-13

Inlet Protection Details of Manufactured Inlet Protection 4-248

Temporary Seeding (TS)



Practice Description

Temporary seeding is the establishment of fast-growing annual vegetation from seed on disturbed areas. Temporary vegetation provides economical erosion control for up to a year and reduces the amount of sediment moving off the site.

This practice applies where short-lived vegetation can be established before final grading or in a season not suitable for planting the desired permanent species. It helps prevent costly maintenance operations on other practices such as sediment basins and sediment barriers. In addition, it reduces problems of mud and dust production from bare soil surfaces during construction. Temporary or permanent seeding is necessary to protect earthen structures such as dikes, diversions, grass-lined channels and the banks and dams of sediment basins.

Planning Considerations

Temporary vegetative cover can provide significant short-term erosion and sediment reduction before establishing perennial vegetation.

Temporary vegetation will reduce the amount of maintenance associated with sediment basins.

Temporary vegetation is used to provide cover for no more than 1 year. Permanent vegetation should be established at the proper planting time for permanent vegetative cover.

Certain plants species used for temporary vegetation will produce large quantities of residue which can provide mulch for establishment of the permanent vegetation.

Proper seedbed preparation and selection of appropriate species are important with this practice. Failure to follow establishment guidelines and recommendations carefully may result in an inadequate or short-lived stand of vegetation that will not control erosion.

The selection of plants for temporary vegetation must be site specific. Factors that should be considered are types of soils, climate, establishment rates, and management requirements of the vegetation. Other factors that may be important are wear, mowing tolerance, and salt tolerance of vegetation.

Seeding properly carried out within the optimum dates has a higher probability of success. It is also possible to have satisfactory establishment when seeding outside these dates. However, as plantings are deviated from the optimum dates, the probability of failure increases rapidly. Seeding dates should be taken into account in scheduling land-disturbing activities.

Site quality impacts both short-term and long-term plant success. Sites that have compacted soils should be modified whenever practical to improve the potential for plant growth.

The operation of equipment is restricted on slopes steeper than 3:1, severely limiting the quality of the seedbed that can be prepared. Provisions for establishment of vegetation on steep slopes can be made during final grading. In construction of fill slopes, for example, the last 4-6" might not be compacted. A loose, rough seedbed with irregularities that hold seeds and fertilizer is essential for hydroseeding. Cut slopes should be roughened (see practice *Land Grading*).

Good mulching practices are critical to protect against erosion on steep slopes. When using straw, anchor with netting or asphalt. On slopes steeper than 2:1, jute, excelsior, or synthetic matting may be required to protect the slope.

The use of irrigation (temporary or permanent) will greatly improve the success of vegetation establishment.

Design Criteria and Installation

Prior to start of installation, plant materials, seeding rates and planting dates should be specified by a qualified design professional. Plans and specifications should be referred to by field personnel throughout the installation process.

Scheduling

Plantings should be made during the specified planting period if possible. When sites become available to plant outside of the recommended planting period, either temporary seeding, mulching or chemical stabilization will be more appropriate than leaving the surface bare for an extended period. If lime and fertilizer application rates are not specified, take soil samples during the final grading operation from the top 6" in each area to be seeded. Submit samples to a soil testing laboratory for lime and fertilizer recommendations.

Plant Selection

Select plants that can be expected to meet planting objectives. To simplify plant selection, use Table TS-1, *Commonly Used Plants for Temporary Cover* and Figure TS-1, *Geographical Areas for Species Adaptation and Seeding Dates*. Seeding mixtures commonly specified by the Mississippi Department of Transportation are an appropriate alternative for plantings on rights-of-ways. Additional information related to plantings in Mississippi is found in Chapter 2 in the section *Non-woody Vegetation for Erosion and Sediment Control*.

Table TS-1 Commonly Used Plants for Temporary Cover

Species	Seeding Rates/Ac	Planting Time	Desired pH Range	Fertilization Rate/Acre	Method of Establishment	Zone of Adaptability
Wheat	90 lbs. alone	9/1 – 11/30	6.0 – 7.0	600 lbs. 13-13-13	Seed	All
Ryegrass	30 lbs.	9/1 – 11/30	6.0 – 7.0	600 lbs. 13-13-13	Seed	All
White Clover	5 lbs	9/1 – 11/30	6.0 – 7.0	400 lbs. 13-13-13	Seed	All
Crimson Clover	25 lbs. alone 15 lbs. mix	9/1 – 11/30	6.0 – 7.0	400 lbs. 13-13-13	Seed	All
Hairy Vetch	30 lbs.	9/1 – 11/30	6.0 – 7.0	400 lbs. 13-13-13	Seed	All
Browntop Millet	40 lbs. alone 15 lbs. mix	4/1 – 8/30	6.0 – 7.0	600 lbs. 13-13-13	Seed	All

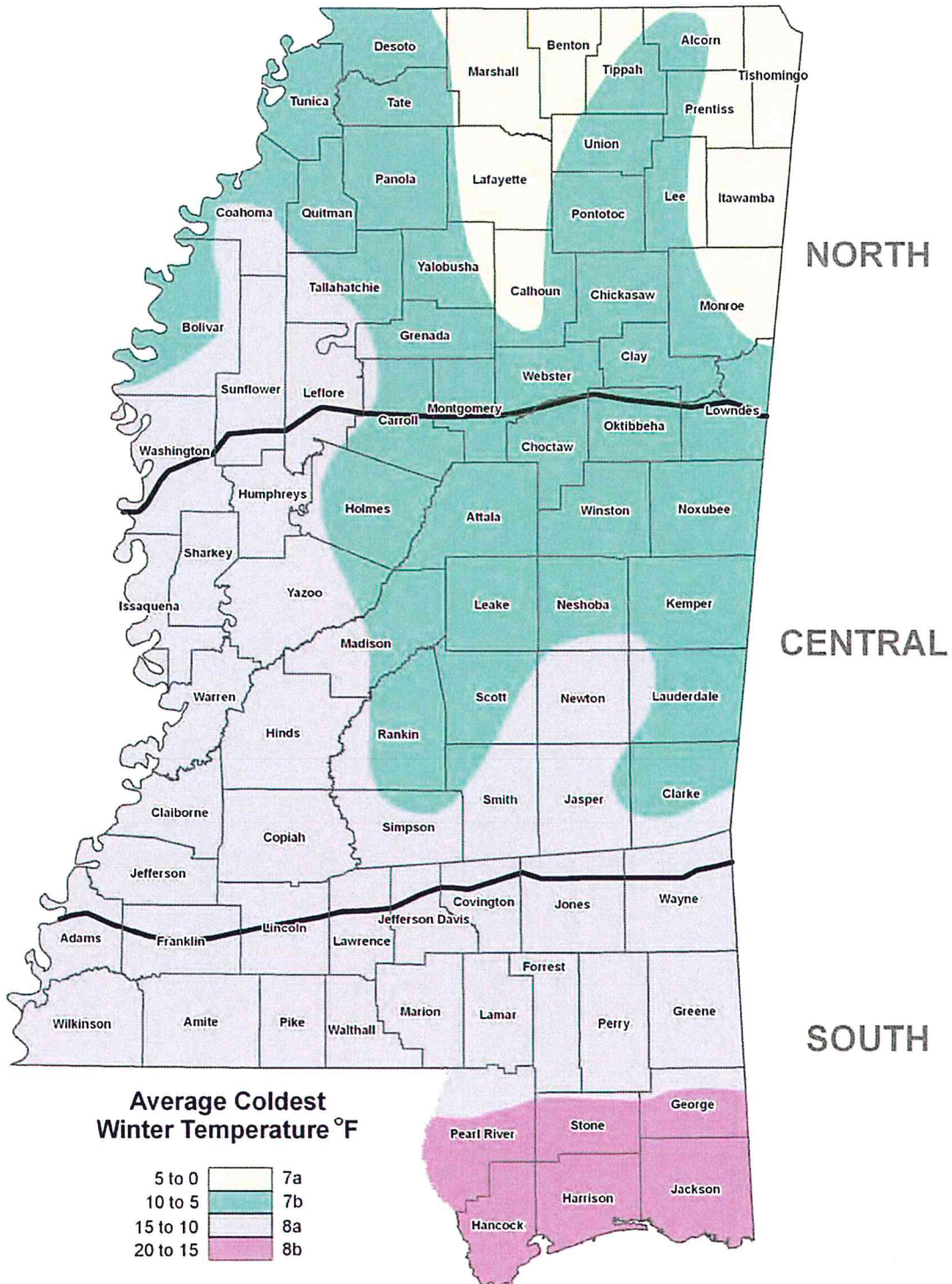

Figure TS- 1 Geographical Areas for Species Adaptation

Site Preparation and Soil Amendments

Complete grading and shaping before applying soil amendments, if needed, to provide a surface on which equipment can safely and efficiently be used to apply soil amendments and accomplish seedbed preparation and seeding. Incorporate lime and fertilizer into the top 6" of soil during seedbed preparation.

Lime

Apply lime according to soil-test recommendations. If a soil test is not available, use 1 ton of agricultural limestone or equivalent per acre on coarse-textured soils and 2 tons per acre on fine textured soils. Do not apply lime to alkaline soils or to areas that have been limed during the preceding 2 years. Other liming materials that may be selected should be provided in amounts that provide equal value to the criteria listed for agricultural lime or be used in combination with agricultural limestone or Selma chalk to provide equivalent values to agricultural limestone.

Fertilizer

Apply fertilizer according to soil-test results. If a soil test is not available, apply 8-24-24 fertilizer.

When vegetation has emerged in a stand and is growing, 30 to 40 lbs/acre (approximately 0.8 lbs/1000 ft²) of additional nitrogen fertilizer should be applied.

Note: Fertilizer can be blended to meet exact fertilizer recommendations. Take soil-test recommendations to local fertilizer dealer for bulk-fertilizer blends. This may be more economical than bagged fertilizer.

Seedbed Preparation

Good seedbed preparation is essential to successful plant establishment. A good seedbed is well pulverized, loose, and smooth. If soils become compacted during grading, loosen them to a depth of 6" to 8" using a ripper or chisel plow.

If rainfall has caused the surface to become sealed or crusted, loosen it just prior to seeding by disking, raking, harrowing, or other suitable methods. When hydroseeding methods are used, the surface should be left with a more irregular surface of clods.

Planting Methods

Seeding

Evenly apply seed using a cyclone seeder (broadcast), drill seeder, cultipacker seeder, or hydroseeder. Broadcast seeding and hydroseeding are appropriate for steep slopes where equipment cannot operate safely. Small grains should be planted no more than 1" deep, and grasses and legumes no more than ½" deep. Seed that are broadcast must be covered by raking or chain dragging, and then lightly firmed with a roller or cultipacker.

Hydroseeding

Surface roughening is particularly important when hydroseeding, as a roughened slope will provide some natural coverage for lime, fertilizer, and seed. The surface should not be compacted or left smooth. Fine seedbed preparation is not necessary

for hydroseeding operations; large clods, stones, and irregularities provide cavities in which seeds can lodge.

Mix seed, use an inoculant if required, and mix a seed carrier with water and apply as slurry uniformly over the area to be treated. The seed carrier should be a cellulose fiber, natural-wood fiber or other approved fiber-mulch material which is dyed an appropriate color to facilitate uniform application of seed. Use the correct legume inoculant at 4 times the recommended rate when adding inoculant to a hydroseeder slurry. The mixture should be applied within one hour after mixing to reduce damage to seed.

Fertilizer should not be mixed with the seed-inoculant mixture because fertilizer salts may damage seed and reduce germination and seedling vigor. Fertilizer may be applied with a hydroseeder as a separate operation after seedlings are established.

Mulching

The use of an appropriate mulch provides instant cover and helps ensure establishment of vegetative cover under normal conditions and is essential to seeding success under harsh site conditions (see the *Mulching Practice* for guidance). Harsh site conditions include the following: slopes steeper than 3:1 and adverse soils (soils that are shallow to rock, rocky, or high in clay or sand). Areas with concentrated flow should be treated differently and require a hydromulch formulated for channels or use of an appropriate erosion control blanket.

Verification of Installation

Check materials and installation for compliance with specifications during installation of products.

Common Problems

Consult with a qualified design professional if the following occurs:

Design specifications for seed variety, seeding dates or mulching cannot be met; substitutions may be required. Unapproved substitutions could lead to failure.

Seeding outside of the recommendations results in an inadequate stand. Reseed according to specifications of a qualified design professional (see recommendations under Maintenance).

Maintenance

Reseeding

Inspect seedings weekly until a stand is established and at least monthly thereafter for stand survival and vigor. Also, inspect the site for erosion.

Eroded areas should be addressed appropriately by filling and/or smoothing, and a reapplication of lime, fertilizer, seed and mulch.

A stand should be uniform and dense for best results. Stand conditions, particularly the vegetative coverage, will determine the extent of remedial actions, such as seedbed preparation and reseeding. A qualified design professional should be consulted to advise on remedial actions. Consider no-till planting.

Fertilizing

If vegetation fails to grow, have the soil tested to determine whether its pH is in the correct range or whether nutrient deficiency is a problem.

Satisfactory establishment may require refertilizing the stand, especially if the planting is made early in the planting season. Follow soil-test recommendations or the specifications provided to establish the planting.

Mowing

Temporary plantings may be mowed and baled or simply mowed to complement the use of the site.

Millet, rye, and wheat may be mowed, but no lower than 6" (closer mowing may damage the stand).

Ryegrass is tolerant of most mowing regimes and may be mowed often and as close as 4" to 6" if this regime is started before it attains tall growth (over 8").

Bermuda grass is tolerant of most mowing regimes and can be mowed often and close, if so desired, during its growing season.

References

Volume 1

Chapter 2

Vegetation for Erosion and Sediment Control 2-10

Chapter 4

Land Grading (LG) 4-16

Topsoiling (TSG) 4-20

Mulching (MU) 4-48

Permanent Seeding (PS) 4-53

Appendices Volume

Appendix G

MDOT Vegetation Schedule G-1

Dust Control (DC)



Practice Description

Dust control includes a wide range of techniques that prevent or reduce movement of wind-borne soil particles (dust) during land disturbing activities. This practice applies to construction routes and other disturbed areas where on-site and off-site damage or hazards may occur if dust is not controlled.

Planning Considerations

Construction activities that disturb soil can be a significant source of air pollution. Large quantities of dust can be generated, especially in “heavy” construction activities such as land grading for road construction and commercial, industrial, or subdivision development.

The scheduling of construction operations so that the least amount of area is disturbed at one time is important in planning for dust control.

The greatest dust problems occur during dry periods. Therefore, to the extent practicable, do not expose large areas of bare soil during drought conditions.

Where wind erosion is a potential cause of dust problems, preserving vegetation should be considered as a passive measure. Leave undisturbed buffer areas between graded areas wherever possible.

Installing temporary- or permanent- surface stabilization measures immediately after completing land grading will minimize dust problems.

Design Criteria and Construction

Dust-control requirements should be designed by a qualified design professional and plans and specifications should be made available to field personnel prior to start of construction. Whenever possible, leave vegetated-buffer areas undisturbed between graded areas.

Scheduling

Schedule construction operations so that the smallest area is disturbed at any one time.

Permanent Methods

Vegetative Cover

For disturbed areas not subject to traffic, vegetation provides the most practical method of dust control. Establish vegetative cover according to the *Permanent Seeding* or *Temporary Seeding Practice*.

Topsoiling

This entails covering the surface with less erosive soil material. See *Topsoiling Practice* for guidance.

Stone

Stone used to stabilize construction roads can also be effective for dust control. Stone should be spread a minimum of 6" thick over construction roads in the disturbed area. For heavily traveled roads or roads subjected to heavy loads, the stone thickness should be 8" to 10". A non-woven geotextile meeting the requirements shown in the Table DC-1 for Class IV geotextiles should be used under the rock when the subgrade is soft or the blow count is less than 10.

Temporary Methods

Mulches

Mulch offers a fast, effective means of controlling dust when properly applied. See *Mulching Practice* for guidelines on planning and installing the practice.

Temporary Vegetative Cover

For disturbed areas where no activity is anticipated for 14 days or longer, temporary seeding can effectively control dust. Establish vegetative cover according to *Temporary Seeding Practice* guidelines.

Calcium Chloride

Calcium chloride may be applied by mechanical spreader as loose, dry granules or flakes at a rate that keeps the surface moist, but not so high as to cause water pollution or plant damage. Sites may need to be retreated because the product degrades over time.

Table DC-1 Requirements for Nonwoven Geotextile

Property	Test method	Class I	Class II	Class III	Class IV ¹
Tensile strength (lb) ²	ASTM D 4632 grab test	180 minimum	120 minimum	90 minimum	115 minimum
Elongation at failure (%) ²	ASTM D 4632	≥ 50	≥ 50	≥ 50	≥ 50
Puncture (pounds)	ASTM D 4833	80 minimum	60 minimum	40 minimum	40 minimum
Ultraviolet light (% residual tensile strength)	ASTM D 4355 150-hr exposure	70 minimum	70 minimum	70 minimum	70 minimum
Apparent opening size (AOS)	ASTM D 4751	As specified max. no.40 ³	As specified max. no.40 ³	As specified max. no.40 ³	As specified max. no.40 ³
Permittivity sec ⁻¹	ASTM D 4491	0.70 minimum	0.70 minimum	0.70 minimum	0.10 minimum

Table copied from NRCS Material Specification 592.

¹ Heat-bonded or resin-bonded geotextile may be used for classes III and IV. They are particularly well suited to class IV. Needle-punched geotextile are required for all other classes.

² Minimum average roll value (weakest principal direction).

³ U.S. standard sieve size.

Spray-on Adhesives

Spray-on adhesives may be used on mineral soils for dust control. Traffic must be kept off treated areas to prevent the product from becoming ineffective. Examples of spray-on adhesives for use in dust control are listed in Table DC-2.

Table DC-2 Spray-on Adhesives for Dust Control on Mineral Soil

Material	Water Dilution	Type of Nozzle	Apply Gal/Ac
Latex Emulsion	12.5:1	Fine Spray	235
Resin In Water	4:1	Fine Spray	300

Chemical Stabilization (CHS)

PAM may be used on mineral soils for dust control. Traffic must be kept off treated areas to prevent the product from becoming ineffective. The manufacturer or supplier shall provide written application methods for PAM and PAM mixtures. The application method shall ensure uniform coverage to the target and avoid drift to non-target areas including waters of the State. The manufacturer or supplier shall also provide written instructions to ensure proper safety, storage, and mixing of the product. Refer to the *Planning Considerations for Chemical Stabilization (PAM) Practice* for planning considerations before deciding to use this product.

Sprinkling or Irrigation

Sprinkling is especially effective for dust control on haul roads and other traffic routes. Sprinkle the site until the surface is wet. Repeat as needed. Also, bare areas may be kept wet with irrigation to control dust as an emergency treatment.

Tillage

Tillage is used to roughen the site and bring clods and moist soil to the surface. This is a temporary emergency measure that can be used on large, open, disturbed areas as soon as soil blowing starts. Begin tilling on the windward edge of the site. The depth of tillage is determined by the depth to moist soil and the amount of moist soil desired at the surface. In sandy soils, the depth to moist soil may make tillage impractical.

Barriers

A board fence, wind fence, sediment fence, hay bales, or similar barriers can control air currents and blowing soil. Place barriers perpendicular to prevailing air currents at intervals about 15 times the barrier height.



Figure 1 Sand Fence (<http://www.gulfmex.org/crp/7004/fence.jpg>)

Street Cleaning

Use a street sweeper to remove the source materials.

Maintenance

Check construction site during vehicular traffic or windy conditions to see if measures are working adequately. Maintain dust-control measures continuously throughout dry-weather periods, until all disturbed areas have been stabilized.

References

BMPs from Volume 1

Chapter 4

Topsoiling (TSG)	4-20
Chemical Stabilization (CHS)	4-25
Mulching (MU)	4-48
Permanent Seeding (PS)	4-53
Temporary Seeding (TS)	4-103

Site Location Map

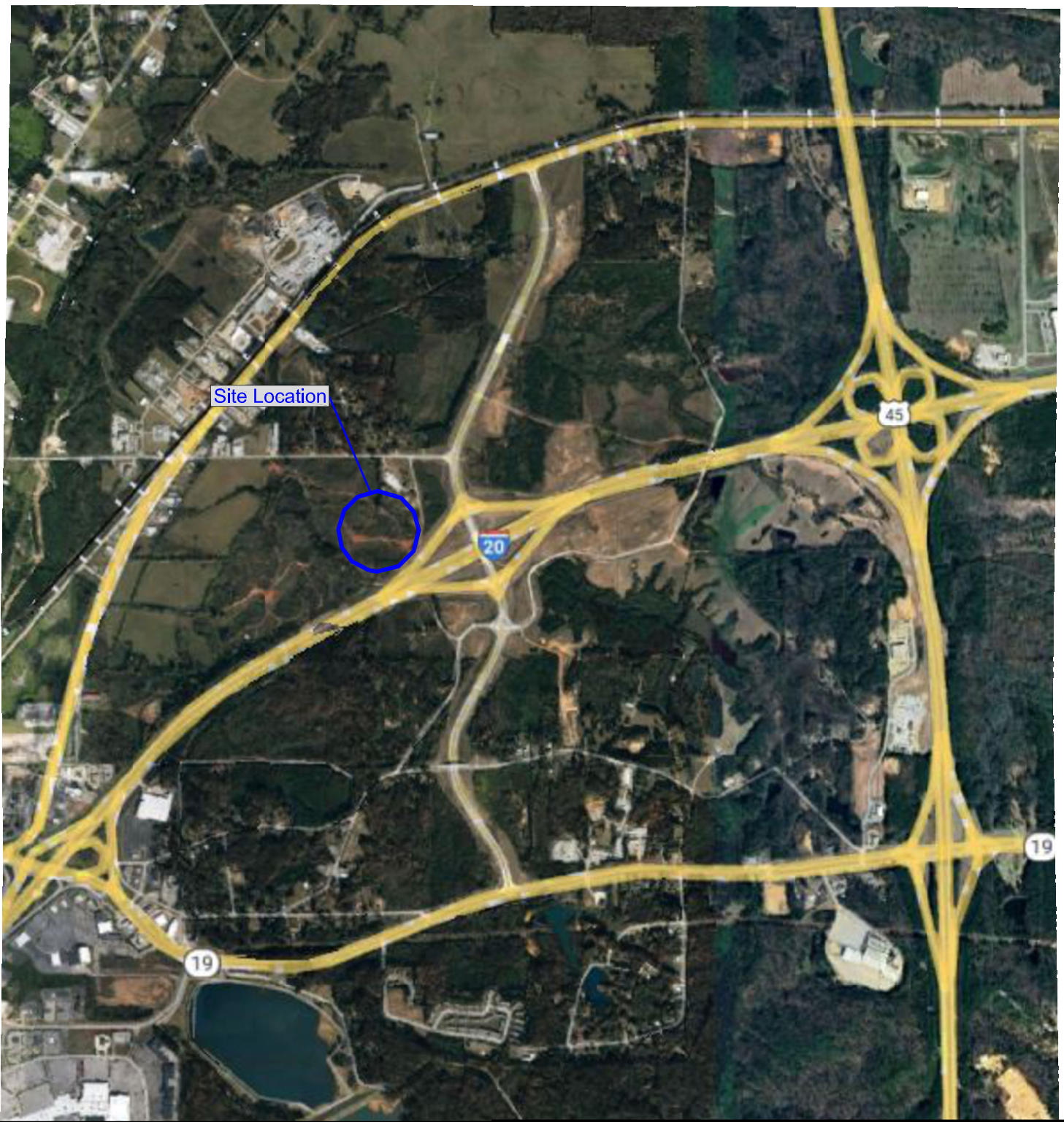

Source: Google Earth

NORTH



Engineering Plus

Planning • Surveying • Testing • Landscape Design
1724-B 23rd Ave. Meridian, Mississippi 39301 (601) 693-4234

Not to Scale

QUADRANGLE MAP

Tri-State Truck Center

Meridian, MS

DWG FILE: N:\Civil 3D Projects\Private
Projects\2023\23-117 Tri-State
Trucking\SWPPP

JOB NO. 23-117
DRAWING NO.

DATE: 10-1-24
DRAWN BY: RLA
CHECKED BY: RLA

SHEET:

1 OF 1

Quadrangle Maps

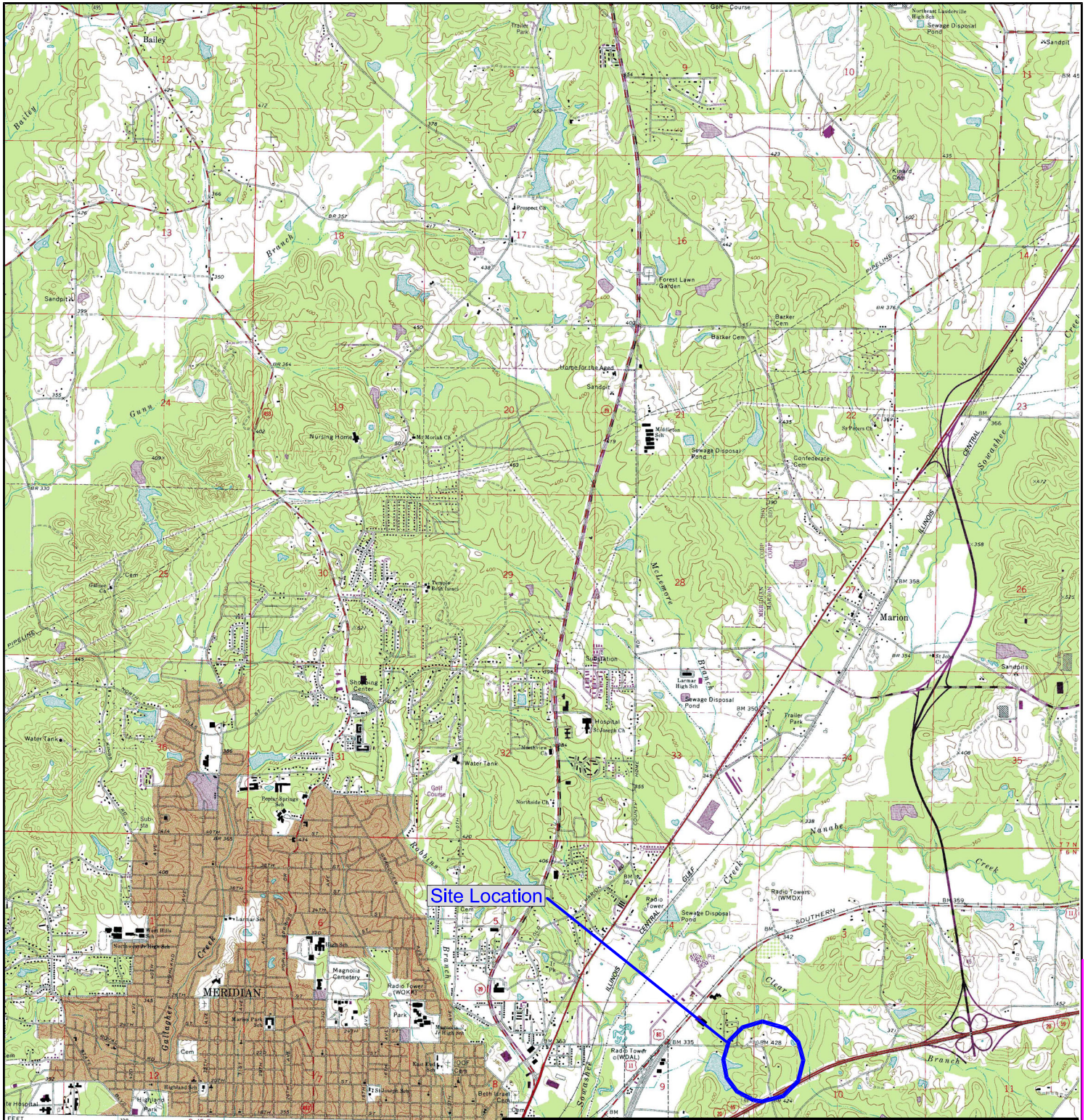

Source: Meridian North Quad

QUADRANGLE MAP

Tri-State Truck Center

Meridian, MS

NORTH



Engineering Plus

Planning · Surveying · Testing · Landscape Design
1724-B 23rd Ave. Meridian, Mississippi 39301 (601) 693-4234

Not to Scale

N:\Civil 3D Projects\Private
DWG FILE: Projects\2023\23-117 Tri-State
Trucking\SWPPP

JOB NO. 23-117
DRAWING NO.

DATE: 10-1-24
DRAWN BY: RLA
CHECKED BY: RLA

SHEET:

1 OF 1

Soil Survey of Lauderdale County, MS

Soil Map—Lauderdale County, Mississippi
(Tri-State Truck Center)

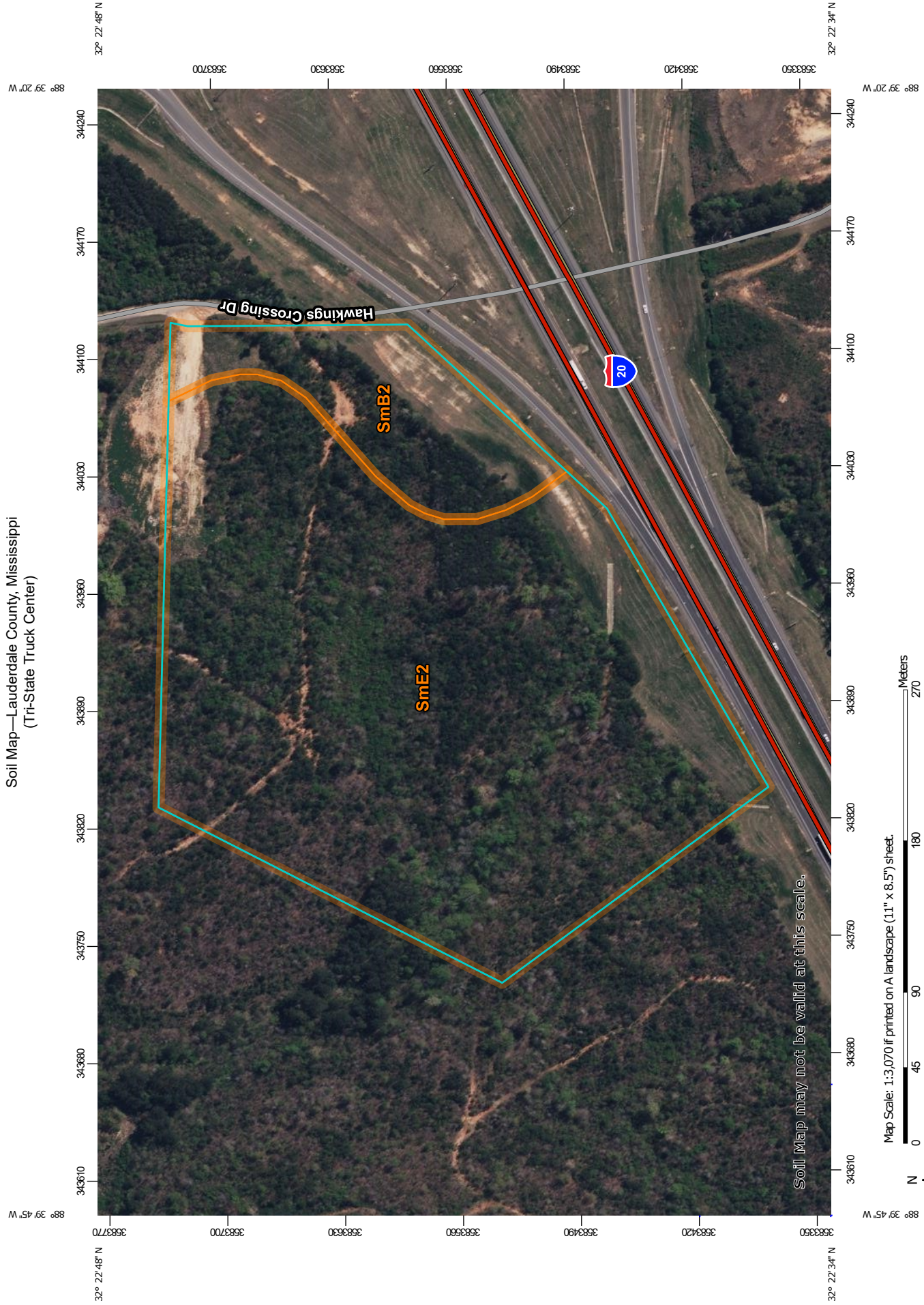

Map Scale: 1:3,070 if printed on A landscape (11" x 8.5") sheet.



Map projection: Web Mercator Corner coordinates: WGS84 Edge tics: UTM Zone 16N WGS84



Natural Resources
Conservation Service

Web Soil Survey
National Cooperative Soil Survey

MAP LEGEND

- Area of Interest (AOI)
- Area of Interest (AOI)
- Soil Map Unit Polygons
- Soil Map Unit Lines
- Soil Map Unit Points
- Special Point Features**
 - Blowout
 - Borrow Pit
 - Clay Spot
 - Closed Depression
 - Gravel Pit
 - Gravelly Spot
 - Landfill
 - Lava Flow
 - Marsh or swamp
 - Mine or Quarry
 - Miscellaneous Water
 - Perennial Water
 - Rock Outcrop
 - Saline Spot
 - Sandy Spot
 - Severely Eroded Spot
 - Sinkhole
 - Slide or Slip
 - Sodic Spot
- Water Features**
 - Streams and Canals
- Transportation**
 - Rails
 - Interstate Highways
 - US Routes
 - Major Roads
 - Local Roads
- Background**
 - Aerial Photography

MAP INFORMATION

The soil surveys that comprise your AOI were mapped at 1:20,000.

Warning: Soil Map may not be valid at this scale.

Enlargement of maps beyond the scale of mapping can cause misunderstanding of the detail of mapping and accuracy of soil line placement. The maps do not show the small areas of contrasting soils that could have been shown at a more detailed scale.

Please rely on the bar scale on each map sheet for map measurements.

Source of Map: Natural Resources Conservation Service
Web Soil Survey URL:
Coordinate System: Web Mercator (EPSG:3857)

Maps from the Web Soil Survey are based on the Web Mercator projection, which preserves direction and shape but distorts distance and area. A projection that preserves area, such as the Albers equal-area conic projection, should be used if more accurate calculations of distance or area are required.

This product is generated from the USDA-NRCS certified data as of the version date(s) listed below.

Soil Survey Area: Lauderdale County, Mississippi
Survey Area Data: Version 19, Sep 6, 2024

Soil map units are labeled (as space allows) for map scales 1:50,000 or larger.

Date(s) aerial images were photographed: Jan 3, 2021—May 8, 2021

The orthophoto or other base map on which the soil lines were compiled and digitized probably differs from the background imagery displayed on these maps. As a result, some minor shifting of map unit boundaries may be evident.

Map Unit Legend

Map Unit Symbol	Map Unit Name	Acres in AOI	Percent of AOI
SmB2	Sweatman fine sandy loam, 2 to 5 percent slopes, moderately eroded	3.4	14.1%
SmE2	Sweatman fine sandy loam, 15 to 35 percent slopes, moderately eroded	20.5	85.9%
Totals for Area of Interest		23.9	100.0%

Erosion Control Plan