



November 15, 2023

Ms. Carrie Barefoot, Environmental Permits Division
Office of Pollution Control
Mississippi Department of Environmental Quality
P. O. Box 2261
Jackson, Mississippi 39225

Re: LCSWPPP Major Modification
Southeastern Timber Products (AI 2014)
Permit Number: MSR107471
Ackerman, Choctaw County, MS

Dear Ms. Barefoot:

Please find enclosed a Major Modification Form and updated Large Construction SWPPP for the Mill Modernization Project at Southeastern Timber in Ackerman, MS.

Please feel free to contact myself by phone at 601-824-1860 or by email at ccook@fce-engineering.com, with any questions regarding this letter.

Sincerely,

Charles Cook, P.E. – Sr. Engineer
FC&E Engineering, LLC

RECEIVED

NOV 15 2023

Dept. of Environmental Quality



MAJOR MODIFICATION FORM
FOR LARGE CONSTRUCTION GENERAL PERMIT
Coverage No. MSR10 7 4 7 1 County Choctaw

INSTRUCTIONS

Coverage recipients shall notify the Mississippi Department of Environmental Quality (MDEQ) at least 30 days in advance of the following activities (check all that apply). This form should be submitted with a modified Storm Water Pollution Prevention Plan (SWPPP), updated USGS topographic map, Corps of Engineers Section 404 documentation and wastewater collection and treatment information, as appropriate.

- SWPPP details have been developed and are being submitted for MDEQ review for subsequent phases of an existing project.
"Footprint" identified in the original LCNOI is proposed to be changed.

This form must be signed by the current coverage recipient under Mississippi's Large Construction General Permit. A different developer of new phases of existing subdivisions must apply for separate permit coverage through the submittal of a new complete LCNOI package. Coverage recipients are authorized to discharge storm water associated with proposed expansions of existing subdivisions or subsequent phases, under the conditions of the General Permit, only upon receipt of written notification of approval by MDEQ. All other modifications, such as changes of erosion and sediment controls used, must be in accordance with ACT6, S-1 (6) and S-2 (7) of the General Permit.

ALL INFORMATION MUST BE COMPLETED (indicate "N/A" where not applicable)

CURRENT COVERAGE RECIPIENT INFORMATION

COVERAGE RECIPIENT CONTACT NAME: Mike Dextrase PHONE # (601) 285-4243
COMPANY NAME: Southeastern Timber Products, LLC
STREET OR P.O. BOX: PO BOX 718
CITY: Ackerman STATE: MS ZIP: 39735 E-MAIL: mdextrase@setimberproducts.com
IS THE APPLICANT DIFFERENT FROM THE CURRENT COVERAGE HOLDER? YES NO

PREPARER/CONSULTANT INFORMATION
(Complete if prepared by someone other than applicant.)

PREPARER/CONSULTANT CONTACT NAME: Ty Faulkner PHONE # (601) 824-1860
COMPANY NAME: FC&E Engineering, LLC
STREET OR P.O. BOX: PO BOX 1774
CITY: Brandon STATE: MS ZIP: 39043 E-MAIL: tyfaulkner@fce-engineering.com
MAY MDEQ CORRESPOND DIRECTLY WITH THE PREPARER / CONSULTANT REGARDING THE PROPOSED PROJECT / MODIFICATION? YES NO

SITE INFORMATION

PROJECT NAME: Southeastern Timber Products/Tolko Landfill Construction & Mill Modification
CITY: Ackerman TRIBAL LAND ID (N/A If not applicable): N/A
Latitude / Longitude Collected at Project Entrance or Construction Start Point:
LATITUDE: 33 degrees 18 minutes 2.75 seconds LONGITUDE: 89 degrees 12 minutes 26.63 seconds
LAT & LONG COLLECTION METHOD (e.g., GPS, Map Interpolation): Map Interpolation - Front Gate
REDUCTION IN ACREAGE: N/A ADDITIONAL ACREAGE TO BE DISTURBED: 1.8
TOTAL PROJECT ACREAGE: 79.8 ESTIMATED CONSTRUCTION END DATE: 12/2027

IS THE PROJECT REROUTING, FILLING OR CROSSING A WATER CONVEYANCE OF ANY KIND? (If yes, contact the U.S. Army Corps of Engineers' Regulatory Branch for permitting requirements.) YES NO

IF THE PROJECT IS A SUBDIVISION OR A COMMERCIAL DEVELOPMENT, HOW WILL SANITARY SEWAGE BE DISPOSED? Check one of the following and attach the pertinent documents.

- Existing Municipal or Commercial System. Please attach plans and specifications for the collection system and the associated "Information Regarding Proposed Wastewater Projects" form or approval from County Utility Authority in Hancock, Harrison, Jackson, Pearl River and Stone Counties. If the plans and specifications cannot be provided at the time of LCNOI submittal, MDEQ will accept written acknowledgement from official(s) responsible for wastewater collection and treatment that the flows generated from the proposed project can and will be transported and treated properly. The letter must include the estimated flow.
- Collection and Treatment System will be Constructed. Please attach a copy of the cover of the NPDES discharge permit from MDEQ or indicate the date the application was submitted to MDEQ (Date: September 26, 2023.)
- Individual Onsite Wastewater Disposal Systems for Subdivisions Less than 35 Lots. Please attach a copy of the Letter of General Acceptance from the Mississippi State Department of Health or certification from a registered professional engineer that the platted lots should support individual onsite wastewater disposal systems.
- Individual Onsite Wastewater Disposal Systems for Subdivisions Greater than 35 Lots. A determination of the feasibility of installing a central sewage collection and treatment system must be made by MDEQ. A copy of the response from MDEQ concerning the feasibility study must be attached. If a central collection and wastewater system is not feasible, then please attach a copy of the Letter of General Acceptance from the State Department of Health or certification from a registered professional engineer that the platted lots should support individual onsite wastewater disposal systems.

INDICATE ANY LOCAL STORM WATER ORDINANCE WITH WHICH THE PROJECT MUST COMPLY:

None.

NEAREST NAMED RECEIVING STREAM: Yockanookany River

IS RECEIVING STREAM ON MISSISSIPPI'S 303(d) LIST OF IMPAIRED WATER BODIES? (The 303(d) list of impaired waters and TMDL stream segments may be found on MDEQ's web site: <https://www.mdeq.ms.gov/water/surface-water/tmdl/>) YES NO

HAS A TMDL BEEN ESTABLISHED FOR THE RECEIVING STREAM SEGMENT? YES NO

I certify under penalty of law that this document and all attachments were prepared under my direction or supervision in accordance with a system designed to assure that qualified personnel properly gathered and evaluated the information submitted. Based on my inquiry of the person or persons who manage the system, or those persons directly responsible for gathering the information, the information submitted is, to the best of my knowledge and belief, true, accurate and complete. I am aware that there are significant penalties for submitting false information, including the possibility of fine and imprisonment for knowing violations.



Signature (must be signed by coverage recipient)

November 13, 2023

Date

Mike Dextrase

Printed Name

Plant Manager

Title

Please submit this form to: Chief, Environmental Permits Division
Office of Pollution Control
MS Department of Environmental Quality
P.O. Box 2261
Jackson, Mississippi 39225

Electronically: <https://www.mdeq.ms.gov/construction-stormwater/>

Unit No.	NOx		CO		VOC		SOx		TSP ¹		PM10 ¹		PM2.5 ¹		H ₂ S		Lead	
	lb/hr	ton/yr	lb/hr	ton/yr	lb/hr	ton/yr	lb/hr	ton/yr	lb/hr	ton/yr	lb/hr	ton/yr	lb/hr	ton/yr	lb/hr	ton/yr	lb/hr	ton/yr
F29-F37	N/A	N/A	N/A	N/A	N/A	N/A	N/A	N/A	0.00	0.00	0.00	0.00	0.00	0.00	N/A	N/A	N/A	N/A
F-38	N/A	N/A	N/A	N/A	N/A	N/A	N/A	N/A	0.00	0.00	0.00	0.00	0.00	0.00	N/A	N/A	N/A	N/A
F-39	N/A	N/A	N/A	N/A	N/A	N/A	N/A	N/A	0.00	0.00	0.00	0.00	0.00	0.00	N/A	N/A	N/A	N/A
7B	3.36	12.22	3.46	12.56	0.37	1.36	0.12	0.44	0.71	2.58	0.71	2.58	0.71	2.58	0.00	0.00	4.7E-05	0.00017
8B	3.36	12.22	3.46	12.56	0.37	1.36	0.12	0.44	0.71	2.58	0.71	2.58	0.71	2.58	0.00	0.00	4.7E-05	0.00017
EP-09	2.94	12.88	7.88	34.52	0.13	0.57	0.06	0.25	2.88	12.63	2.88	12.63	2.88	12.63	0.00	0.00	0.00	0.00
EP-11 (F40-F67)	-	-	-	-	-	-	-	-	2.59	11.35	0.26	1.14	0.26	1.14	-	-	-	-
EP-12	2.25	5.63	2.38	5.94	0.00	0.00	0.00	0.00	3.06	7.70	3.06	7.70	3.06	7.70	0.00	0.00	0.00	0.00
F-68/F-69	-	-	-	-	-	-	-	-	8.17	5.37	4.13	2.63	0.48	0.28	-	-	-	-
ENG1	2.02	2.52	0.43	0.54	0.16	0.20	0.13	0.17	0.14	0.18	0.14	0.18	0.14	0.18				
GEN3	0.61	0.76	0.65	0.82	0.12	0.16	0.10	0.13	0.07	0.08	0.07	0.08	0.07	0.08				
ENG2	0.14	0.18	0.09	0.11	0.28	0.35	0.01	0.01	0.01	0.01	0.01	0.01	0.01	0.01				
ENG3	0.78	0.97	0.17	0.21	0.06	0.08	0.05	0.06	0.06	0.07	0.06	0.07	0.06	0.07				
ENG4	1.22	1.53	0.81	1.02	0.25	0.31	0.20	0.25	0.07	0.08	0.07	0.08	0.07	0.08				
ENG5	1.22	1.53	0.81	1.02	0.25	0.31	0.20	0.25	0.07	0.08	0.07	0.08	0.07	0.08				
ENG6	1.22	1.53	0.81	1.02	0.25	0.31	0.20	0.25	0.07	0.08	0.07	0.08	0.07	0.08				
ENG7	1.22	1.53	0.81	1.02	0.25	0.31	0.20	0.25	0.07	0.08	0.07	0.08	0.07	0.08				
ENG8	10.18	12.72	10.85	13.57	2.07	2.59	1.69	2.11	1.09	1.36	1.09	1.36	1.09	1.36				
ENG9	1.22	1.53	0.81	1.02	0.25	0.31	0.20	0.25	0.07	0.08	0.07	0.08	0.07	0.08				
ENG10	2.28	2.85	1.21	1.51	0.53	0.66	0.43	0.54	0.07	0.09	0.07	0.09	0.07	0.09				
Totals	62.73	193.52	68.51	233.36	7.28	17.17	4.39	8.24	114.11	411.39	61.45	230.41	31.74	124.01	0.00	0.00	0.00	0.00

¹Condensable Particulate Matter: Include condensable particulate matter emissions for PM10 and PM2.5 if the source is a combustion source. Do not include condensable particulate matter for TSP unless TSP is set equal to PM10 and PM2.5.

LARGE CONSTRUCTION STORMWATER POLLUTION PREVENTION PLAN (LCSWPPP)

Woodwaste Rubbish Disposal Sites & Mill Modernization Project

Southeastern Timber Products LLC

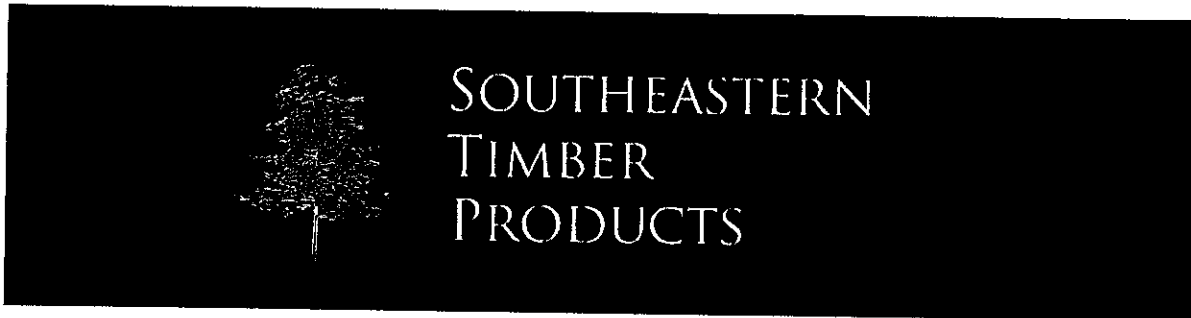

Ackerman, Mississippi

May 2023 (Updated Nov. 2023)

Prepared for:

Southeastern Timber Products

240 PCA Road
Ackerman, Mississippi 39735

Prepared by:



FC&E Engineering, LLC
917 Marquette Road
Brandon, MS 39042
(601) 824-1860
www.fce-engineering.com

TABLE OF CONTENTS

ABOUT THIS PLAN.....iii

CERTIFICATION.....v

POLLUTION PREVENTION TEAM.....vi

1.0 SITE DESCRIPTION/MAP1

1.1 FACILITY DRAINAGE2

2.0 INVENTORY OF EXPOSED MATERIALS3

3.0 SIGNIFICANT SPILLS AND LEAKS.....3

4.0 NON-STORMWATER DISCHARGES3

5.0 SAMPLING DATA3

6.0 BEST MANAGEMENT PRACTICES.....3

6.1 GOOD HOUSEKEEPING MEASURES AND CONTROLS.....4

6.2 PREVENTIVE MAINTENANCE AND INSPECTION5

6.3 SPILL PREVENTION AND RESPONSE PROCEDURES5

6.4 EMPLOYEE TRAINING6

6.5 SEDIMENT AND EROSION CONTROL.....8

6.6 MANAGEMENT OF RUNOFF9

7.0 WEEKLY SITE INSPECTIONS AND EVALUATIONS.....11

8.0 RECORDKEEPING AND REPORTING.....12

9.0 SPECIAL REQUIREMENTS12

9.1 SECTION 313 SPECIAL REQUIREMENTS.....12

9.2 DISCHARGES TO LARGE OR MEDIUM SEPARATE STORMWATER SYSTEMS.....12

10.0 MONITORING AND REPORTING REQUIREMENTS13

11.0 SECURITY.....13

LIST OF FIGURES

- FIGURE 1: SITE LOCATION TOPOGRAPHY MAPS**
- FIGURE 2: SITE LOCATION AERIAL MAPS**
- FIGURE 3: SITE STORMWATER MAP**
- FIGURE 4: PROPOSED LAYOUT MAP**
- FIGURE 5: CIVIL EROSION CONTROL SHEET SET W/ DETAIL DRAWINGS**

TABLE OF CONTENTS (CONTINUED)

LIST OF WORKSHEETS

WORKSHEET 1: MATERIALS EXPOSED TO STORMWATER

WORKSHEET 2: SUMMARY OF MATERIALS EXPOSED TO STORMWATER

WORKSHEET 3: LIST OF SIGNIFICANT SPILLS AND LEAKS

WORKSHEET 4: WEEKLY INSPECTION CHECKLIST

LIST OF APPENDICES

APPENDIX A: STATE STORMWATER LARGE CONSTRUCTION NOTICE OF INTENT & GENERAL PERMIT FOR CONSTRUCTION ACTIVITIES AT LARGE CONSTRUCTION SITES

APPENDIX B: WEEKLY INSPECTION RECORDS

APPENDIX C: RECORDS OF SIGNIFICANT SPILLS AND LEAKS & NOTIFICATIONS TO AGENCIES

APPENDIX D: MISSISSIPPI SWPPP GUIDANCE MANUAL FOR CONSTRUCTION ACTIVITIES

APPENDIX E: DRAINAGE AREAS & SEDIMENTATION BASIN STORAGE CALCULATIONS

APPENDIX F: CONSTRUCTION PLANS

About This Plan

This Construction Stormwater Pollution Prevention Plan (LCSWPPP) was prepared by FC&E Engineering, LLC (FC&E) to help your facility comply with the Mississippi General Stormwater Permit for Large Construction Activities issued by the Mississippi Department of Environmental Quality (MDEQ). The permit requires you to prepare a LCSWPPP. This Plan has been prepared with the intent of meeting the LCSWPPP requirements.

The intent of the Plan is to minimize stormwater pollution from your facility during construction activities associated with the modification to your production facility. The Plan specifies the procedures your staff will follow and the engineering controls your facility will implement to prevent or minimize stormwater from coming in contact with potential pollutants, or to contain stormwater that does come in contact with potential pollutants. Your permit requires that you comply with this Plan. Items that need your immediate attention include:

1. Coverage under the State Stormwater Large Construction General Permit will be issued by the MDEQ upon approval of the Large Construction Notice of Intent LCNOI and Construction Stormwater Pollution Prevention Plan LCSWPPP. **The completed LCSWPPP, and a site map should be submitted with the Large Construction Notice of Intent (LCNOI) to the Chief, Environmental Permits Division of the MDEQ at least 30 days prior to the commencement of construction.**
2. The completed LCNOI and this LCSWPPP are to be kept on site and utilized by you and your contractor to ensure that stormwater leaving the site is uncontaminated. A copy of the permit and the LCNOI are included in Appendix A.

This LCSWPPP has been written in consideration of the requirements of this general permit.

3. Section 7.0 of this Plan describes the Weekly Site Inspections that must be conducted by the Site Manager (or someone designated by the Site Manager). This section also describes the required information to be included on the inspection form. Worksheet 4 contains the required Inspection and Certification form for Large Construction Activity requiring erosion and sediment controls and a site-specific inspection form. Completed inspections using Worksheet 4 should be stored in Appendix B.
4. Based on the results of each inspection, the control measures and practices will be revised (if appropriate) immediately following the inspection or prior to additional construction activity taking place. In addition, if the inspection report lists changes at the facility that have a significant effect on the potential for the discharge of pollutants to surface waters, the LCSWPPP will be amended.

*Large Construction Stormwater Pollution Prevention Plan (LCSWPPP)
Southeastern Timber Products – Ackerman, Mississippi*

5. A copy of Mississippi's LCSWPPP Guidance Manual for Construction Activities is included in Appendix D for reference and use. Specific BMPs referenced herein are based on the guidelines of this manual.
6. Within 30 days of final stabilization of the covered project a completed Request for Termination (RFT) form must be submitted to the permit board. Upon receiving the completed RFT form the MDEQ staff will inspect the site. If no sediment and erosion control problems are identified and adequate permanent controls are established the owner or operator will receive a termination letter. Coverage is not terminated until done so in writing. Failing to submit a RFT is a violation of permit conditions.

SITE INFORMATION

Name and Address of the Site:

Southeastern Timber Products LLC - Ackerman

240 PCA Road

Ackerman, Mississippi 39735 Telephone No.: 601-331-0630

Facility Contact: Mike Dextrase, Plant Manager

County: Choctaw Latitude: 33° 18' 02.691" N Longitude: 89° 12' 26.61" W

Drainage Basin: Yockanookany River

Name and Address of the Owner/Operator:

Southeastern Timber Products LLC

372 Stirling Bridge Drive

Ormond Beach, FL 32174 Telephone No.: 601-982-8728

Owner Contact: Mr. David Manley, Vice President US Operations

CERTIFICATION

I certify under penalty of law that this document and all attachments were prepared under my direction or supervision in accordance with a system designed to assure that qualified personnel properly gathered and evaluated the information submitted. Based on my inquiry of the person or persons who manage the system, or those persons directly responsible for gathering the information, the information submitted is, to the best of my knowledge and belief, true, accurate, and complete. I am aware that there are significant penalties for submitting false information, including the possibility of fines and imprisonment for knowing violations.

Name: Mike Dextrase

Signature: 

Title: Plant Manager

Certification Date: November 13, 2023

Pollution Prevention Team

Name: Mike Dextrase – Plant Manager
Phone: cell: 601-331-0630
Responsibilities: Mike Dextrase is responsible for stormwater pollution prevention activities at the facility. The role as leader of the Pollution Prevention Team includes the following responsibilities.

- (a) Updating the LCSWPPP as required
- (b) Performing weekly inspections of the facility
- (c) Ensuring that stormwater pollution prevention is included in employee training classes
- (d) Supervising spill and leak cleanup
- (e) Supervising facility and procedural changes identified to minimize pollutant exposure to stormwater
- (f) Communicating with regulatory agencies as needed

Name: Peter Marshall – Construction Manager
Phone: cell: 250-540-2153
Responsibilities: Mr. Marshall assists in implementing and updating the SWPPP. In the event that the Pollution Prevention Team Leader is unavailable, he assumes the responsibilities as outlined above.

Name: Mike Dextrase
Title: Plant Manager
Facility Name: Southeastern Timber Products LLC - Ackerman
Phone: 601-331-0630
Responsibilities: is the responsible official for the facility. He is responsible for supporting the stormwater management team by providing adequate resources to complete the activities and programs identified in the LCSWPPP. He is also required to sign legal certifications as identified in the LCSWPPP.

1.0 SITE DESCRIPTION/MAP

Southeastern Timber Products (STP) operates a facility in Ackerman, MS that manufactures dimensional lumber and is classified under Standard Industrial Classification (SIC) code 2421. The facility plans to undergo a mill modernization process in order to increase output and update their management of lumber products. Also, the facility is in the process of constructing one of two previously permitted rubbish disposal sites on their property. The proposed Southeastern Timber Products Mill Modernization Project and Woodwaste Rubbish Landfill construction sites are located at 240 PCA Road near Ackerman, Choctaw County, Mississippi. Upon completion of construction activities for the rubbish sites, Southeastern Timber Products intends to operate a landfill for Class II Waste Site for woodwaste generated from their nearby sawmill operations. The facility encompasses approximately 261 acres under the control of Southeastern Timber Products. The construction projects are described in the following section.

Construction Process

Rubbish Disposal Sites

The two woodwaste rubbish landfills will be located on STP's property about 2 miles south of Ackerman, MS. The landfills are identified as the North and South landfills (Site A and B, respectively). The first landfill, referred to as Site A, has begun the storage of material and is located at approximately 33° 17' 47.14" N and 89° 12' 44.21" W. Site A has a disturbance footprint of approximately 15 acres. Site A utilizes an existing pond (West Pond) as a sediment basin and discharges through the existing stormwater outfall (SW006). Eventually, the west pond will be incorporated into Site A, and at that time the existing overflow pond will be utilized as a sediment basin until construction is complete. As Site A begins to end its usefulness, the South landfill (Site B) will begin construction and will disturb approximately 10 acres. Site B will be located at approximately 33° 17' 33.13" N and 89° 12' 36.17" W. A sediment basin / retention pond may be incorporated (if required, due to acreage disturbed or soil conditions) into the construction of Site B to control and capture sediment leaving the working site during the construction of Site B. The landfills will be constructed in phases – as one cell reaches its capacity the next cell will be constructed. Erosion control measures will be updated to accurately reflect the dynamic conditions for each site. It is estimated that approximately twenty-five (25) acres will be disturbed between the two landfill construction projects over the life of the rubbish sites.

Mill Modernization Project

Southeastern Timber Products plans to begin site upgrades of their Ackerman Mill in order to increase output and modernize their manufacturing process. Current plans include the installation of two additional direct-fired continuous dry kilns (CDKs) – each equipped with a natural gas burner – sawmill additions with new log crane, a new scale house, a greenfield planer mill, ancillary support equipment, absorption fields for sanitary/wastewater system improvement, and site road improvements. Construction Plan drawings for Southeastern Timber's sanitary/wastewater system improvement are included as **Appendix F**.

STP plans to operate their two existing batch kilns and existing CDK for lumber drying until the mill upgrades are complete and the process can be switched over to an exclusively CDK drying process. Once the new CDKs are online and the process is running appropriately, STP plans to decommission the older batch kilns and associated structures.

The modernization project is estimated to encompass up to fifty-five (55) acres. Portions of this property will be disturbed at a time as internal roads, utilities and new kilns are added. Erosion control measures and best management practices (BMPs) will be in place prior to commencement of site disturbance or construction of the project. Stormwater drainage patterns and identification of site figures for the landfill sites and mill modifications are detailed in the following section.

1.1 Facility Drainage & Surrounding Properties

Stormwater falling on Site A's (North Landfill) construction area flows south and west through sheet flow patterns to the Wet Deck Pond 1 (or West Pond), following the natural slope of the area. As previously stated, Pond 1 is being utilized as a sediment basin / retention basin for the stormwater runoff from Rubbish Site A. The water that collects in Pond 1 can either be recirculated for use as log spray or, if needed, can be discharged through SW-006. As the placement of material in the North Landfill progresses, material will be excavated from north to south and the spoils will be utilized for rubbish cover and construction of the landfill itself.

As previously stated, Site B (South Landfill) is planned for future use, not expected to be constructed until several years in the future, as Site A nears capacity. Current stormwater patterns through the specified footprint of Site B generally proceed south in a sheet flow pattern, following the natural slope of the area. A sediment basin / retention pond may be incorporated (if required, due to acreage disturbed or soil conditions) into the stormwater management of Site B to control and capture sediment leaving the working site during its construction. However, it is expected that most of the rainwater during the construction of Site B and its respective cells will absorb into the ground rather than running off the property.

At present, stormwater falling within the project boundary of the mill modernization project will generally flow into Wet Deck Pond 2 – a no discharge pond. Any remaining stormwater runoff from the project will flow to existing Outfalls SW003, SW004, or SW005. These outfalls have been previously permitted under Southeastern Timber Products Baseline Industrial Stormwater Permit.

The Site Location Maps, presented as **Figure 1 & 2**, show the landfill boundaries and surrounding areas. The Site Stormwater Map, which illustrates the surface flow directions and flow pathways throughout the entire site, is presented as **Figure 3**. The proposed site layout is shown in **Figure 4** and the Civil Erosion Control Sheet Set and BMP details are included as **Figure 5**.

2.0 INVENTORY OF EXPOSED MATERIALS

Worksheet 1 contains a detailed inventory of materials used, stored, or produced onsite that are exposed to stormwater. Worksheet 2 summarizes the significant materials exposed to stormwater.

3.0 SIGNIFICANT SPILLS AND LEAKS

There have been no significant spills or leaks exposed to stormwater over the last 3 years. Worksheet 3 is included so the facility will have a ready mechanism to record information on any spill exposed to stormwater that may occur during the period of the permit.

4.0 NON-STORMWATER DISCHARGES

The construction project described in the LCNOI and this LCSWPPP does not involve or foresee any non-stormwater discharges. The following are prohibited non-stormwater discharges;

- Wastewater from washout of concrete (unless managed by an appropriate control)
- Wastewater from washout and cleanout of stucco, paint, form release oils, curing compounds and other construction materials
- Fuels, oils, or other pollutants used in vehicle and equipment operation and maintenance
- Soaps or solvents used in vehicle and equipment washing
- Wastewater from sanitary facilities, including portable toilets
- Dewatering activities, including discharges from dewatering of trenches and excavations unless managed by BMPs.

5.0 SAMPLING DATA

No monitoring is required as described in Section 10.0, Monitoring and Reporting Requirements.

6.0 BEST MANAGEMENT PRACTICES

Best management practices (BMPs) are measures taken at the facility to prevent or mitigate water pollution from sources other than the manufacturing or treatment process. BMPs are broad ranging and may include processes, procedures, human actions, or construction. BMPs are aimed at preventing spills and similar environmental incidents by stressing the importance of management and employee awareness of potential spill situations.

The following subsections describe BMPs that are to be included in the facility's LCSWPPP. These BMPs follow the guidelines described in the guidance document included in Appendix D.

6.1 Good Housekeeping Measures and Controls

Good housekeeping practices are designed to maintain a clean and orderly work environment. At this facility, the following types of good housekeeping measures are implemented in an effort to prevent pollutants from entering stormwater discharges.

Operation and Maintenance

- Garbage and waste materials are regularly picked up and properly disposed of.
- Equipment is routinely inspected to make sure it is in working order and no leaks are occurring.
- The importance of spill cleanup procedures is communicated to employees.
- A daily walk through of construction/disturbed areas are encouraged to identify any potential issues that may have an effect on stormwater leaving the site.
- Removal of sediment that has accumulated in or near any sediment control measures (sediment basins, silt fences, hay bales, etc.), storm water conveyance channels, storm drain inlets, or water course conveyance within the construction site. Typically, sediment removal shall be performed when sediment is accumulating in an area that has high risk of discharge from the property or when BMPs are one-third to one-half of their design capacity.

Material Storage Practices

- Limit disturbed areas to only those with near term development. Avoid exposing soil through disturbance to rain events if possible.
- Soil stockpiles will be located away from drainage ditches and have silt fencing placed along the downward slope to prevent sediment runoff.
- Employees are instructed to maintain materials in an organized manner.
 - Containers, drums, and bags of material are stored away from direct traffic routes to prevent accidental spills.
 - Containers are stacked according to manufacturers' instructions.
 - As appropriate, containers are stored on pallets to prevent corrosion.
- See Section 6.5 for more specific BMPs related to erosion.

Employee Participation

- Information on best management practices is discussed during employee training sessions.
- Good housekeeping measures are discussed at employee meetings.

6.2 Preventive Maintenance and Inspection

The facility's preventive maintenance and inspection program includes:

- Timely inspections and maintenance of stormwater management devices.
- Proper maintenance of facility equipment and systems.

6.3 Spill Prevention and Response Procedures

The Spill Prevention Control and Countermeasures (SPCC) Plan requirements of 40 CFR 112 may be applicable if large quantities of fuel are stored on site. Limited amounts of oil and/or chemical products are anticipated to be stored onsite during construction. Southeastern Timber's facility-wide SPCC plan will cover any response and preventive measures to address storage of chemicals and oil products or spills thereof. This LCSWPPP will address some spill prevention and response issues. In the event of a spill, employees are instructed to make every effort to contain the release, notify the Pollution Prevention Team Leader or Spill Coordinator, and prevent any release from leaving the facility site. It will be the Pollution Prevention Team Leader or Spill Coordinator's responsibility to determine if the spill needs to be reported to the regulatory authorities through the Responsible Official.

Additional preventative measures utilized by the site are: 1) proper storage and disposal of used batteries 2) proper labeling of drums containing used oil and ensuring that stored drums are kept inside buildings and away from potential accidental tippage situations 3) maintaining accurate labels and inventory of chemical materials, solvents, paints, lubricants etc. and 4) storage of solvents and flammable materials in a proper and safe manner.

6.3.1 Likely Releases and In-place Preventative Controls

Spills and releases are most likely to result from potential equipment failure or operator error. This section summarizes potential causes of releases and associated in-place preventative controls.

1. Operator error during loading/unloading or refueling operations. Potential errors include overfilling, not disconnecting lines prior to vehicle departure, drain valves left open, or fill valves left open allowing precipitation to enter and cause tank overflow. Specific procedures have been developed to minimize this potential and include regular periodic

inspections, locking valves when not in use, and on-the-job training in correct procedures.

2. Piping, pressure fittings, tank ruptures, or other forms of equipment failure. The rate and quantity of a release would depend on the location of the rupture. Release rate could be assumed to be the total volume of the tank associated with the piping or fittings being released in a 15-minute timeframe. The release to the environment would be at that rate but the quantity would be the total volume minus the secondary containment volume. To minimize the potential for a significant release, regular inspections and maintenance are performed with noted problems addressed in a timely manner by repair, replacement, or equipment taken out of service.
3. Puncture of tank or associated piping by heavy equipment. Operators of equipment and vehicles are well trained in operating large equipment on the facility. Rate and quantity to be released would be the same as that discussed in item 2. Additionally, tanks and piping are highly visible by size, signage, flagging, or protective paint color. In the event of night traffic, sufficient lighting is provided to make tanks and piping visible.
4. Small drips, leaks and spills from lines or valves. Release rates would be negligible and are not likely to produce significant quantities or environmental impacts. To minimize release, equipment is inspected regularly, repaired in a timely manner when a problem is discovered, and corrective action implemented with released material promptly cleaned up. In general, this type of release presents a very low risk of potential impact.

6.4 Employee Training

New employees or contractors receive initial training in stormwater pollution prevention before they begin their work assignments at the construction site. Thereafter, training is provided, and stormwater pollution prevention discussed as needed at the safety meetings that employees or contractors attend.

Topics discussed and names of attendees are stored with personnel files.

The training program addresses three major areas:

- Spill prevention and response
- Good housekeeping
- Materials management practices including BMPs and erosion control techniques.

A brief description of each topic covered as part of the training program is outlined below.

Spill Prevention and Response

Limited amounts of oil and/or chemical products are anticipated to be stored onsite during construction. Southeastern Timber Products facility-wide SPCC plan (if required) will cover any response and preventive measures to address storage of chemicals and oil products or spills

thereof. **The operator/contractor should be made aware to contact Southeastern Timber Products, the Pollution Prevention Team Leader or Spill Coordinator in the event of a spill of oil or potentially hazardous chemicals.** Training involving spills are discussed briefly in Section 6.3 above and as follows:

- Employees involved in the stormwater pollution prevention program are shown the potential spill areas and drainage routes at the facility.
- Employees are given instructions on how to report spills and the appropriate individuals to contact.
- Proper material handling procedures and storage requirements are discussed.

Good Housekeeping

- Employees are instructed to perform regular vacuuming or sweeping in their work areas to prevent stormwater from becoming contaminated with waste materials.
- Employees are instructed to promptly clean up spilled materials to prevent stormwater from becoming contaminated.
- Locations of housekeeping and spill response equipment and supplies are provided to all employees.
- Where appropriate, employees are provided instructions on the proper methods to secure drums and other containers. Those working near containers/drums are also instructed to routinely check the integrity of the containers to make sure there are no leaks.

Materials Management Practices

- Employees are instructed to maintain materials in an organized manner.
- Toxic and hazardous substances onsite should be clearly marked.
- Proper and safe handling procedures are discussed with employees who are responsible for handling any toxic and hazardous substances.

Material Inventory Procedures

- An up-to-date inventory of hazardous and non-hazardous materials kept at the facility is maintained at the main office.
- Containers are labeled with the name of the material, expiration date, and health hazards, as required.
- Storage areas with hazardous materials have been specifically designed to contain spills, as required.

6.5 Sediment and Erosion Control

During the construction phase, the opportunity for stormwater to be impacted by sediment runoff is likely unless measures are incorporated and implemented to ensure proper sediment control is in place. No areas were identified as problematic from an erosion standpoint. However, during the construction phase and in the event that soil is disturbed at the facility, creating a potential for erosion, the following measures will be taken to reduce the amount of soil erosion at the facility:

- Make sure construction entrances/exits are in place (see Figure 5 Sheet Set for locations and detail drawings)
- Control storm water volume and velocity within the site to minimize soil erosion;
- Control storm water discharges, including both peak flow rates and total storm water volume, to minimize erosion at outlets and to minimize downstream channel and stream bank erosion;
- Minimize the amount of soil exposed during construction activity;
- Minimize the disturbance of steep slopes;
- Minimize the sediment discharges from the site;
- Minimize soil compaction and, unless infeasible, preserve topsoil;
- Maintain a 50-foot natural vegetative buffer between disturbed areas and waters of the U.S.
- Direct storm water to vegetated areas, silt fences, hay bales, etc. to aid in filtration, infiltration, velocity reduction and diffusion of the discharge;
- Transport runoff down steep slopes through lined channels or piping;
- Implement structural control practices along any shallow drainage ditches such as:
 - Filter (silt) fences
 - Brush barriers
 - Rip rap check dams
- Minimize the amount of cut and fill, and soil compaction; and
- Minimize off-site vehicle tracking of sediments.

Upon completion of the construction phase, disturbed areas will be managed and re-vegetated as soon as practicable. Where applicable, disturbed areas will be stabilized by temporary seeding, permanent seeding, mulching and/or maintaining vegetative buffer strips as each case dictates. Although the nature of the planned operations of the site after the construction does not involve

activities that could potentially disturb the soil in a negative way, the following measures will be implemented post-construction to reduce the chance of future soil erosion at the facility:

- Vegetate or re-vegetate disturbed soil as soon as possible with common vegetative covers such as grass, trees, shrubs, bark, mulch, or straw. Vegetative practices must begin immediately upon completion of a phased project or when a disturbed area will be left for 14 days or longer.
- Stabilize ditch banks onsite whenever possible with riprap, gabion, reinforced concrete, log cribbing, grid pavers, or asphalt.
- Implement permanent structural controls along any shallow drainage ditches and along disturbed sloped areas with significant sheet flow runoff.
- Erosion and sediment controls consisting of vegetative and structural practices shall be designed to preserve vegetation or allow timely re-vegetation of disturbed areas and divert storm water from exposed soils or otherwise limit runoff from exposed areas.

Site-specific BMPs and erosion controls to be implemented during and after the construction phase are shown in the Figure 5 Sheet Set (**Figure 5.1 & Figure 5.2**, specifically) and should be constructed in accordance with the erosion control detail drawings contained within the Figure 5 Sheet Set.

6.6 Management of Runoff

Stormwater runoff at this facility is managed by several practices including:

Baseline BMPs

- Drainage areas larger than 10 acres (or otherwise deemed necessary) will flow into designated sediment basins to ensure the capture of sediments and controlled release of stormwater. See **Figures 5.1 & 5.3** for locations and sizes of the site drainage areas and sediment basins. **Appendix E** includes calculations and numerical info on the drainage areas and sediment basins.
- Storm water drains collect water through the facilities roads.
- Routine inspection of any fuel and oil storage tanks brought or temporarily stored onsite, and prompt cleanup and repair as needed.
- Culverts under roads.
- Proper vegetation of disturbed soil areas as soon as possible after disturbance with common vegetative covers such as grass, trees, shrubs, bark, mulch, or straw.

- Stabilization of ditch banks onsite whenever possible with riprap, gabion, reinforced concrete, log cribbing, grid pavers, or asphalt.
- Implementation of structural control practices along the shallow drainage ditches such as:
 - Filter (silt) fences
 - Brush barriers
 - Sediment traps

6.6.1 Vegetative Practices

Construction projects will proceed in a planned sequence and every attempt will be made to prevent erosion. A 50-foot natural vegetative buffer should be maintained between disturbed areas and waters of the U.S. All disturbed areas will be managed and re-vegetated as soon as practicable after construction activities. Where applicable, disturbed areas will be stabilized by temporary seeding, permanent seeding, mulching and/or maintaining vegetative buffer strips as each case dictates. Vegetative practices must be implemented immediately upon completion of a phased project or when a disturbed area will be left for 14 days or longer.

6.6.2 Structural Practices

Structural erosion control measures shall be implemented as needed. The structural practices shall divert flows from exposed soils, store flows or otherwise limit runoff from exposed areas. The structural methods will include straw bale dikes, silt fences, earth dikes, brush barriers, drainage swales, check dams, level spreaders, detention/retention basins, sediment traps, temporary sediment basins or equivalent sediment controls.

For drainage locations that serve an area with ten (10) or more disturbed acres at one time, a temporary (or permanent) sediment basin providing at least 3,600 ft³ of storage per acre drained shall be provided until final stabilization of the site. Sediment basins must be installed before major site grading and utilize outlet structures that withdraw water from the surface and that are designed for a minimum 2-year, 24-hour storm event (4.5 inch). If flocculants are proposed for use, they must be approved and implemented in accordance with Section 6.6.3.

The controls should, to the extent practicable:

1. Divert upslope surface water around disturbed areas by means of diversion dikes;
2. Limit exposure of disturbed areas to the shortest practical time;
3. Minimize the amount of disturbed area at any given time;
4. Implement best management practices to mitigate adverse impacts from storm water runoff;
5. Slow rainfall runoff velocities to prevent erosive flows;
6. Provide for construction entrances/exits wherever traffic will be entering/leaving a construction site and moving directly onto a paved public road;

7. Protect storm drain inlets that could receive storm water from construction activities by surrounding or covering with a filter material until final stabilization has been achieved;
8. Minimize the amount of cut and fill by constructing the sediment/detention basins with the spoils from the excavation to be used in berms; and
9. Re-vegetate disturbed areas as soon as possible. Vegetative practices must begin immediately when a disturbed area will be left for 14 days or longer.

6.6.3 Flocculant Application

Some construction projects may need to supplement conventional storm water management systems with flocculants to meet state water quality standards. Flocculants meeting the criteria listed in ACT8; Condition No. T-1 of the Large Construction Storm Water General Permit may be submitted for approval of use as part of the overall storm water management system. If flocculant application is required by Southeastern Timber Products, the notice to MDEQ must list the proposed flocculants to be used, describe the method, frequency and location of introduction and identify the location of BMPs where flocculated material will settle. If flocculants are approved, sediment basins must be downstream of the point of flocculant introduction and include baffles to increase sediment removal efficiency and turbidity reduction.

7.0 WEEKLY SITE INSPECTIONS AND EVALUATIONS

Best Management Practices (BMPs) must be in place prior to construction. As needed, additional BMPs must be put in place as construction progresses. Qualified personnel will conduct a weekly site inspection for a minimum of four inspections per month:

1. Confirm the accuracy of the description of potential pollutant sources contained in the LCSWPPP.
2. Determine the effectiveness of the Plan and its BMPs for preventing stormwater pollution due to construction activity.
3. Assess compliance with the terms and conditions of the stormwater large construction general permit and if necessary, implement new BMPs that will protect stormwater runoff from polluting nearby streams.

The weekly site inspections are to be conducted by the Site Manager or their designee. During the evaluation, material handling and storage areas, construction activity, and other potential sources of pollution will be visually inspected for evidence of actual or potential pollutant discharges to the drainage system. Erosion controls and structural stormwater management devices will also be inspected to ensure that each is operating correctly. Any poorly functioning erosion controls or sediment controls, non-compliant discharges, or any other deficiencies observed during the inspections required under this permit shall be corrected as soon as possible.

*Large Construction Stormwater Pollution Prevention Plan (LCSWPPP)
Southeastern Timber Products Company – Ackerman, Mississippi*

Worksheet 4, which includes a site-specific inspection form and the required MDEQ weekly inspection form, is provided to assist in the weekly inspections.

The results of each inspection will be documented on the form provided as Worksheet 4 and signed by an authorized company official. The report will describe:

- Name and address of the person making the inspection;
- Date and time of the inspection; and
- Whether any deficiencies were noted. If deficiencies were noted, then list the corrective action taken.

Inspections must continue until such time that planned construction activities have been completed, land disturbing activities have ceased and disturbed areas have been stabilized with no significant erosion occurring. The inspection reports will be retained at the facility for at least 3 years after the date that the construction activity was completed. Weekly inspection reports are to be stored in Appendix B.

Based on the results of each inspection, the description of potential pollutant sources and measures and controls will be revised (if appropriate) immediately following the inspection or prior to additional construction activity taking place. In addition, if the inspection report lists changes at the facility that have a significant effect on the potential for the discharge of pollutants to surface waters, the LCSWPPP will be amended.

8.0 RECORDKEEPING AND REPORTING

A recordkeeping system has been set up at the facility for documenting spills, leaks, and other discharges, including discharges of hazardous substances in reportable quantities. The records contain the following information:

- Date and time of the incident
- Duration of the spill/leak/discharge
- Cause of the spill/leak/discharge
- Response procedures implemented
- Persons notified
- Environmental problems associated with the spill/leak/discharge

A separate recordkeeping system has been established to document inspection and maintenance activities.

Records of spills and leaks are recorded using Worksheet 3 and stored in Appendix C. Records of weekly site inspections of construction activities are retained in the LCSWPPP for at least 3 years after the completion of the construction activity. Records of weekly inspections are kept in Appendix B.

9.0 SPECIAL REQUIREMENTS

9.1 Section 313 Special Requirements

This facility does not have Section 313 chemicals that are exposed to stormwater.

9.2 Discharges to Large or Medium Separate Stormwater Systems

This facility does not discharge to a municipal separate stormwater system.

10.0 MONITORING AND REPORTING REQUIREMENTS

No monitoring and reporting are required for this facility. Monitoring requirements will be re-evaluated if the material storage locations or facility drainage patterns are substantially altered.

11.0 SECURITY



Security is an important consideration to prevent a spill or release from accidental or unknowing entry or from vandalism. Therefore, to protect the facility, several security measures have been taken. These measures include:

- 1) The property has fencing or wooded terrain on all sides to prevent unauthorized vehicle entry and deter trespassers.
- 2) The facility is adequately lit throughout and on all roadways and operation processes.

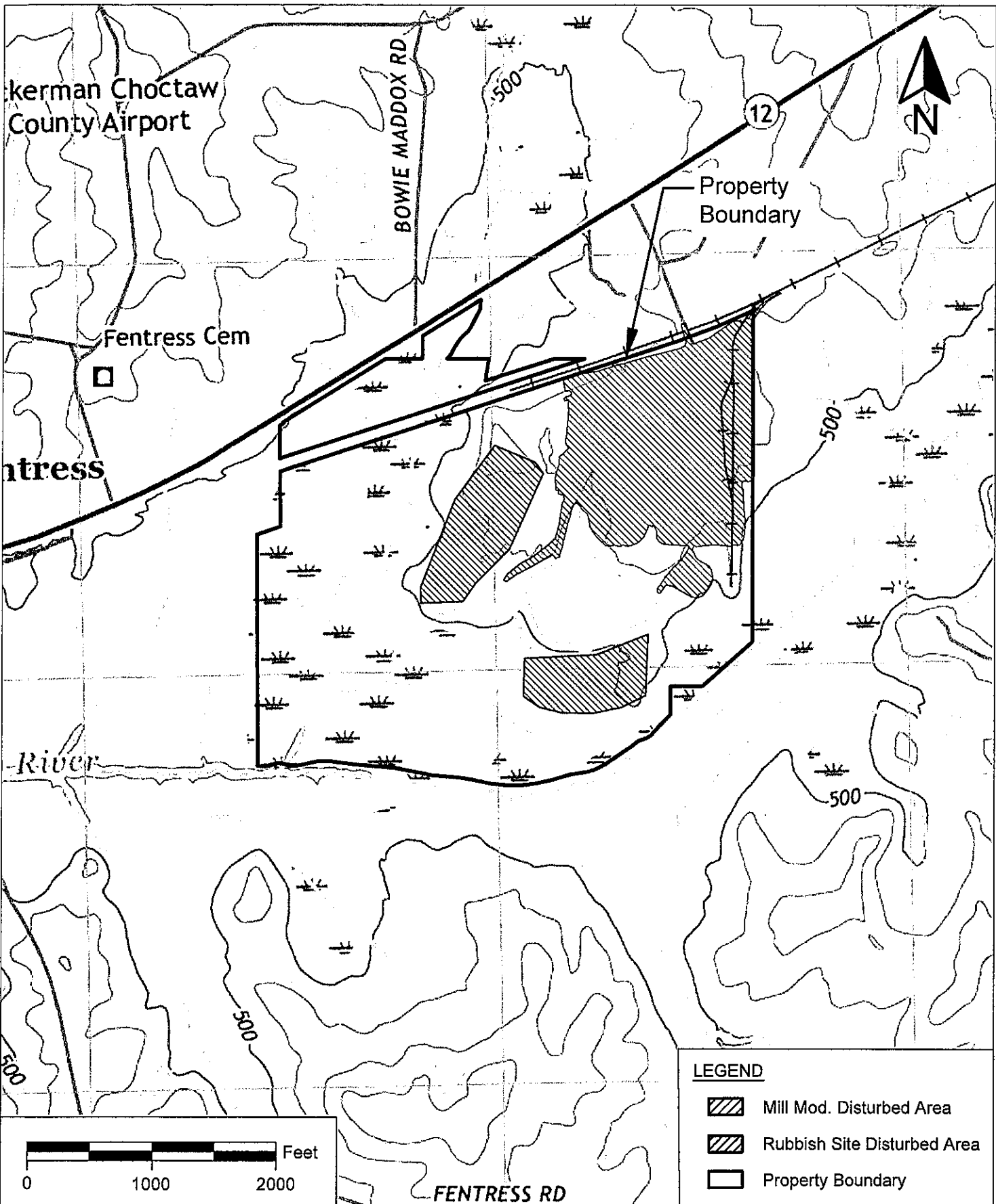
Figures 1: Site Location Topographic Map



LEGEND

-  Mill Mod. Disturbed Area
-  Rubbish Site Disturbed Area
-  Property Boundary



Southeastern Timber Products
 N 33° 17' 51.46", W 89° 12' 32.61"
 204 PCA Road
 Ackerman, Choctaw County, MS

Drawing #:	Figure 1
Drawing Name:	Site Location Topographic Map
Project:	LCSWPPP
Data Source:	USGS Topo
Date Drawn:	4/19/23 (upd. 11/3/23) Drawn By: TF

Figure 2: Site Location Aerial Map

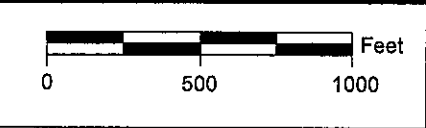
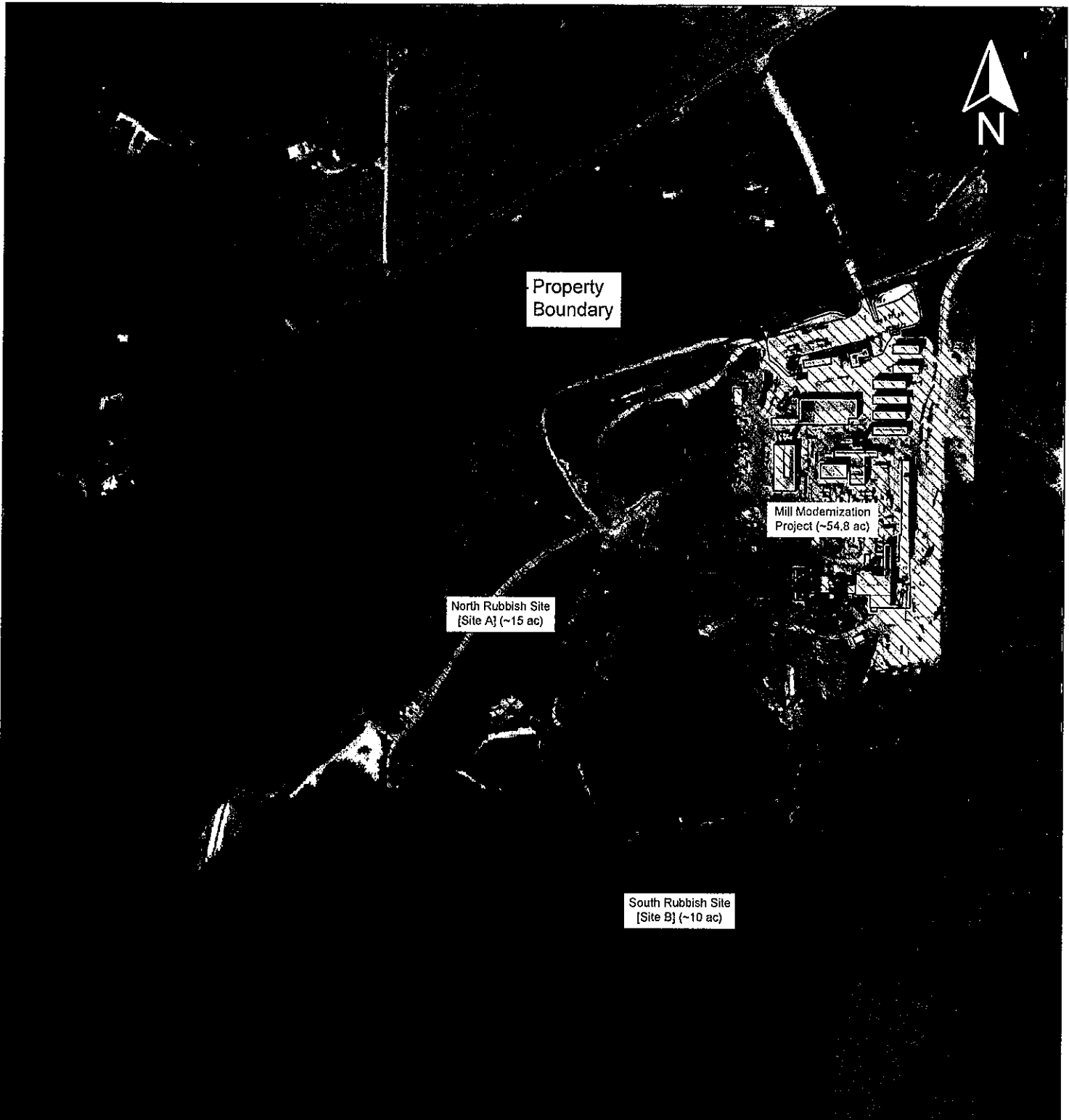

LEGEND	
	Mill Mod. Disturbed Area
	Rubbish Site Disturbed Area
	Property Boundary



Southeastern Timber Products
 N 33° 17' 51.46", W 89° 12' 32.61"
 204 PCA Road
 Ackerman, Choctaw County, MS

Drawing #:	Figure 2
Drawing Name:	Site Location Aerial Map
Project:	LCSWPPP
Data Source:	Google Earth Imagery
Date Drawn:	4/19/23 (upd. 11/3/23) Drawn By: TF

Figure 3: Site Stormwater Map

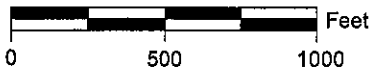
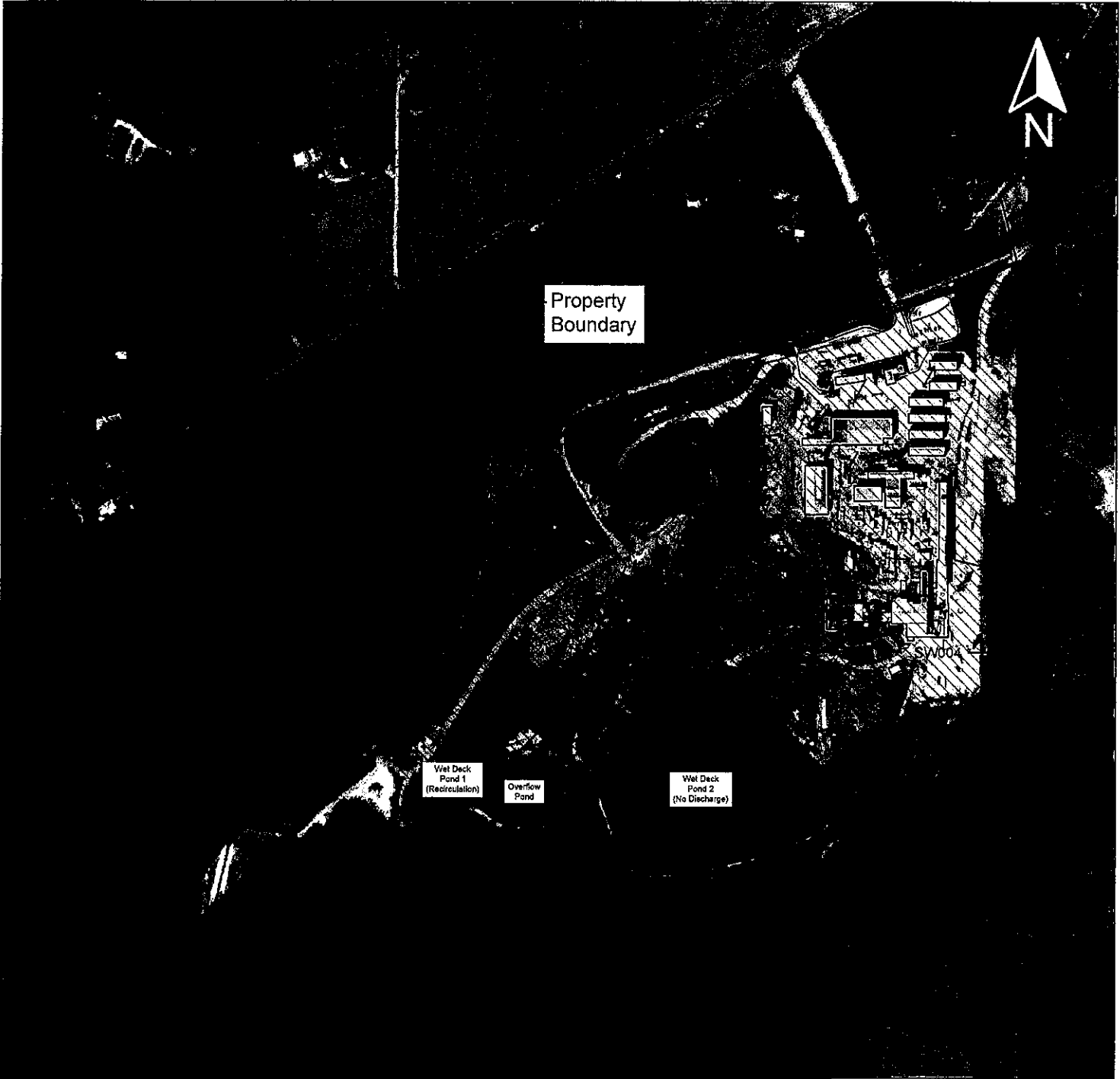

Note: The outfalls shown on the map are existing stormwater outfalls permitted under STP's previously-issued Baseline Industrial Stormwater Permit. Outfalls 003-005, and the No Discharge Pond will be utilized during construction of the Mill Modernization project for management of stormwater, as outlined in the LCSWPPP.

LEGEND

- SW Outfall
- SW Flow Path
- Culvert
- Pond
- ▨ Mill Mod. Disturbed Area
- ▩ Rubbish Site Disturbed Area
- Property Boundary



FC&E
Engineering, I.L.C.
Water • Soils • Air • Compliance

Southeastern Timber Products
N 33° 17' 51.46", W 89° 12' 32.61"
204 PCA Road
Ackerman, Choctaw County, MS

Drawing #:	Figure 3
Drawing Name:	Site Stormwater Map
Project:	LCSWPPP
Data Source:	Google Earth Imagery
Date Drawn:	4/19/23 (upd. 11/3/23) Drawn By: TF

Figure 4: Proposed Layout Map

Figure 5: Civil Erosion Control Sheet Set w/ Detail Drawings

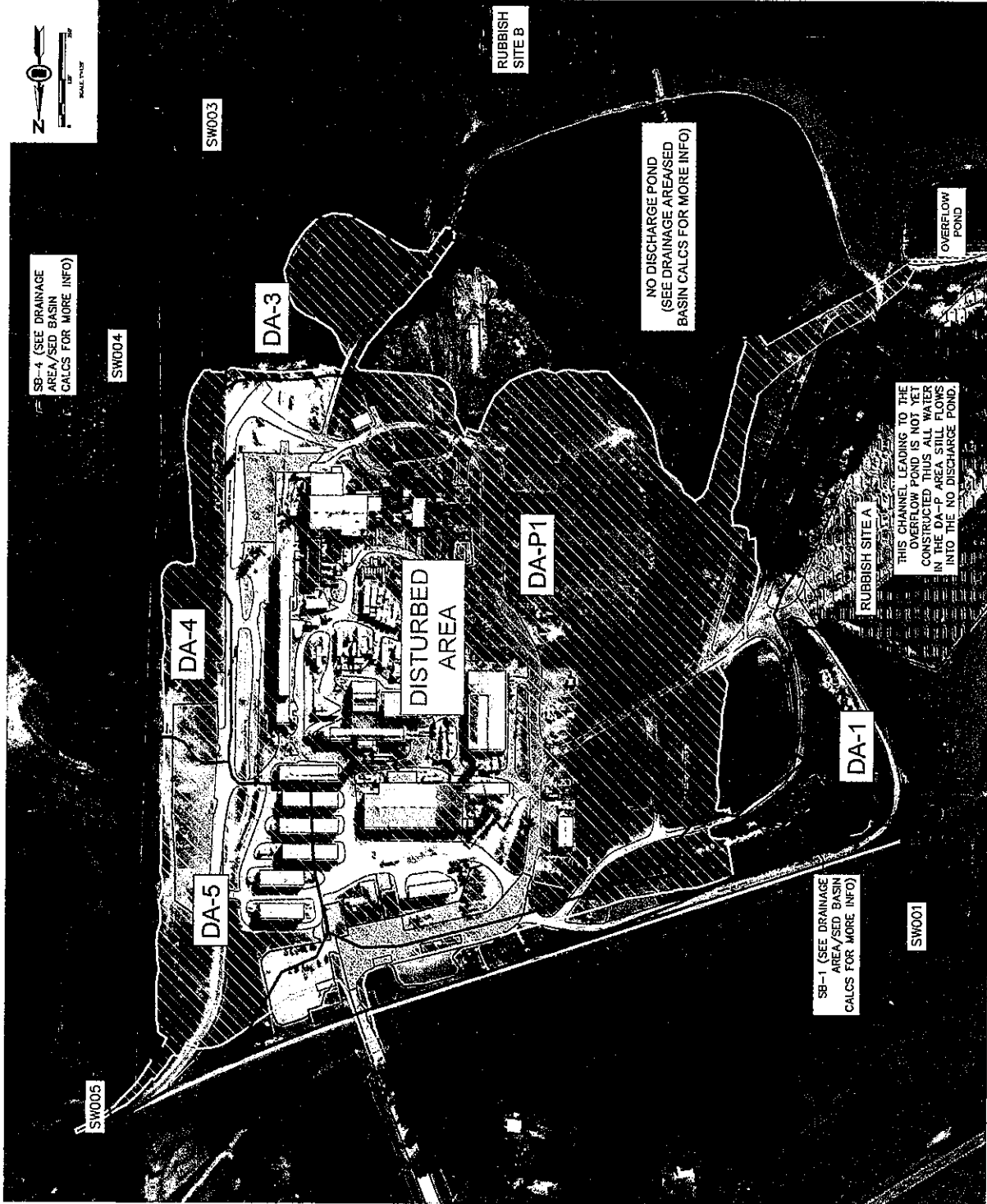

SB-4 (SEE DRAINAGE AREA/SED BASIN CALCS FOR MORE INFO)

SW004

SW003

DA-3

DISTURBED AREA

DA-P1

RUBBISH SITE B

NO DISCHARGE POND (SEE DRAINAGE AREA/SED BASIN CALCS FOR MORE INFO)

OVERFLOW POND

THIS CHANNEL LEADING TO THE OVERFLOW POND IS NOT YET CONSTRUCTED AND ALL WATER IN THIS AREA WILL BE DISCHARGED INTO THE NO DISCHARGE POND.

RUBBISH SITE A

DA-1

SB-1 (SEE DRAINAGE AREA/SED BASIN CALCS FOR MORE INFO)

SW001



LEGEND

- Sediment Basin
- SW Outfall
- Drainage Area
- Disturbed Footprint

THIS DOCUMENT HAS BEEN MODIFIED FROM ITS ORIGINAL STATE. FOR USE ONLY AS REFERENCE WITH THE SITE STORMWATER PLAN.

**EXISTING DRAINAGE AREAS
FIGURE 5.1**

EROSION CONTROL PLAN -- EXISTING/1
SCALE: 1" = 125'

MS-SOUTHPOKERING CO.
REGISTERED PROFESSIONAL ENGINEER

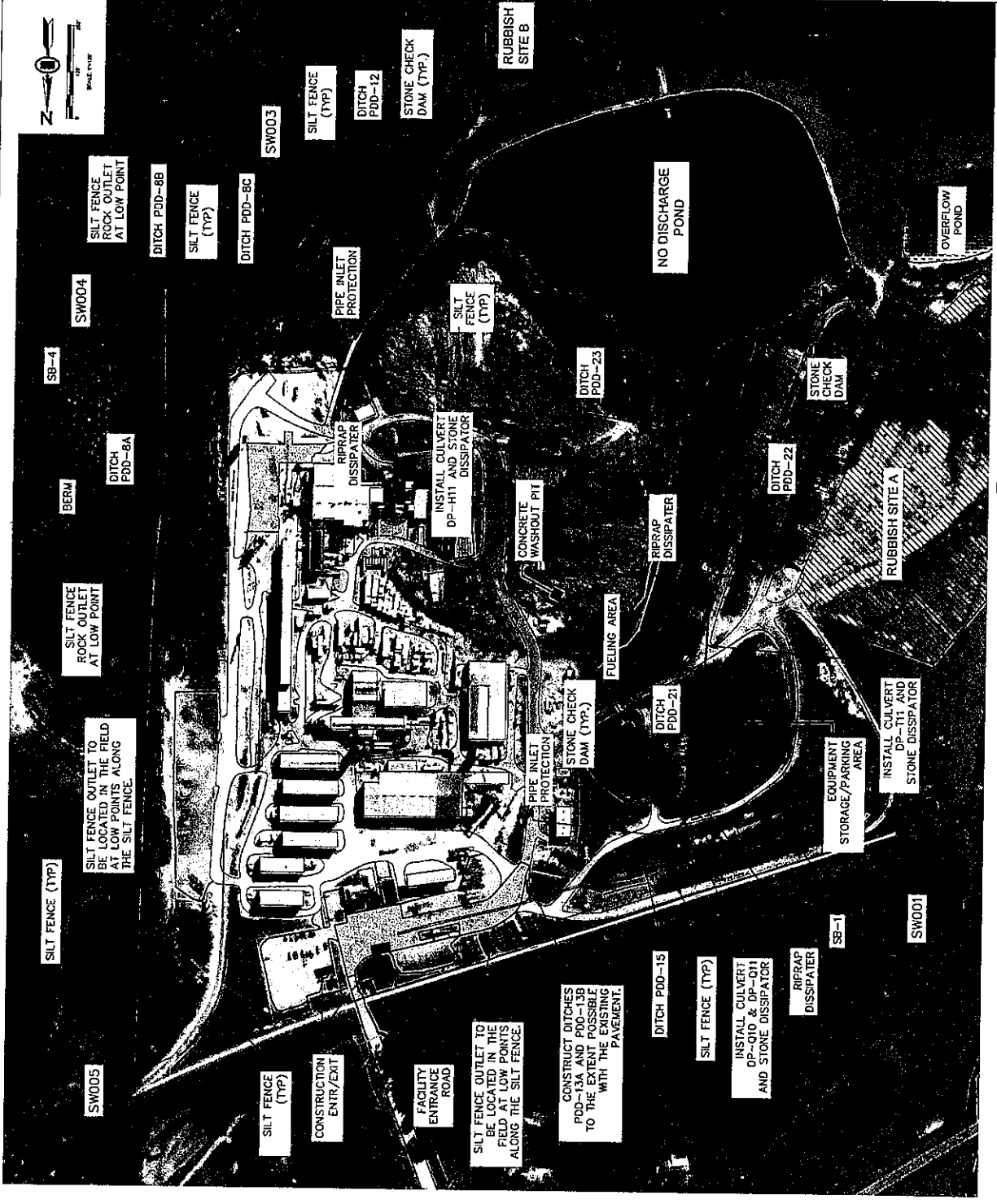

BUILDING KEY

1765	ADMINISTRATION OFFICE
1766	LOG CRANE
1767	LOG PROCESSING BUILDING
1768	FINISHED LUMBER SHED
1769	LOGGING LUMBER SHED
1770	COOLING LUMBER SHED
1771	BARK TRUCK BN
1772	SMALL BUILDING
1773	TRUCK TAPPING SHOP
1774	TRIMMER/SORTER
1775	UNBUNDLING RACK
1776	TRUCK TAPPING BUILDING
1777	PARIS STORAGE BUILDING
1778	NEW SCALE HOUSE
1779	CRK 1
1780	WEST INCOMING SCALE
1781	CRK 2
1782	WEST OUTGOING SCALE
1783	CRK 3 (FUTURE)
1784	EAST OUTGOING SCALE
1785	PLANT/MILL BUILDING

- EROSION CONTROL NOTES**
- SEE DRAWING 9816-1000-13-PP002 FOR OUTLET DISSIPATOR DETAIL AND SPEC.
 - SEE DRAWING 9816-1000-08-CW003 EROSION CONTROL DETAIL SHEET FOR STONE CHECK DAMS, NOTES, AND DETAILS.
 - SEE DRAWING 9816-1000-08-CW004 EROSION CONTROL DETAIL SHEET FOR PERMANENT DRAINAGE DITCH DETAIL AND DITCH SUMMARY TABLE FOR TEMPORARY AND PERMANENT DITCH LINING.

EROSION CONTROL LEGEND

[Symbol]	SILT FENCE
[Symbol]	SILT FENCE ROCK OUTLET
[Symbol]	SITE DITCH
[Symbol]	CULVERT
[Symbol]	PIPE INLET PROTECTION
[Symbol]	STONE CHECK DAM
[Symbol]	CONSTRUCTION EXIT
[Symbol]	SEDIMENT BASIN

THIS DOCUMENT HAS BEEN MODIFIED FROM ITS ORIGINAL STATE. FOR USE ONLY AS REFERENCE WITH THE SITE STORMWATER PLAN.

BMP MAP - INITIAL CONTROLS
FIGURE 5.2





EROSION CONTROL PLAN - EXISTING
SCALE: 1" = 125'

MCSOUTHENGINEERING CO.
MISSISSIPPI REGISTRATION # 346

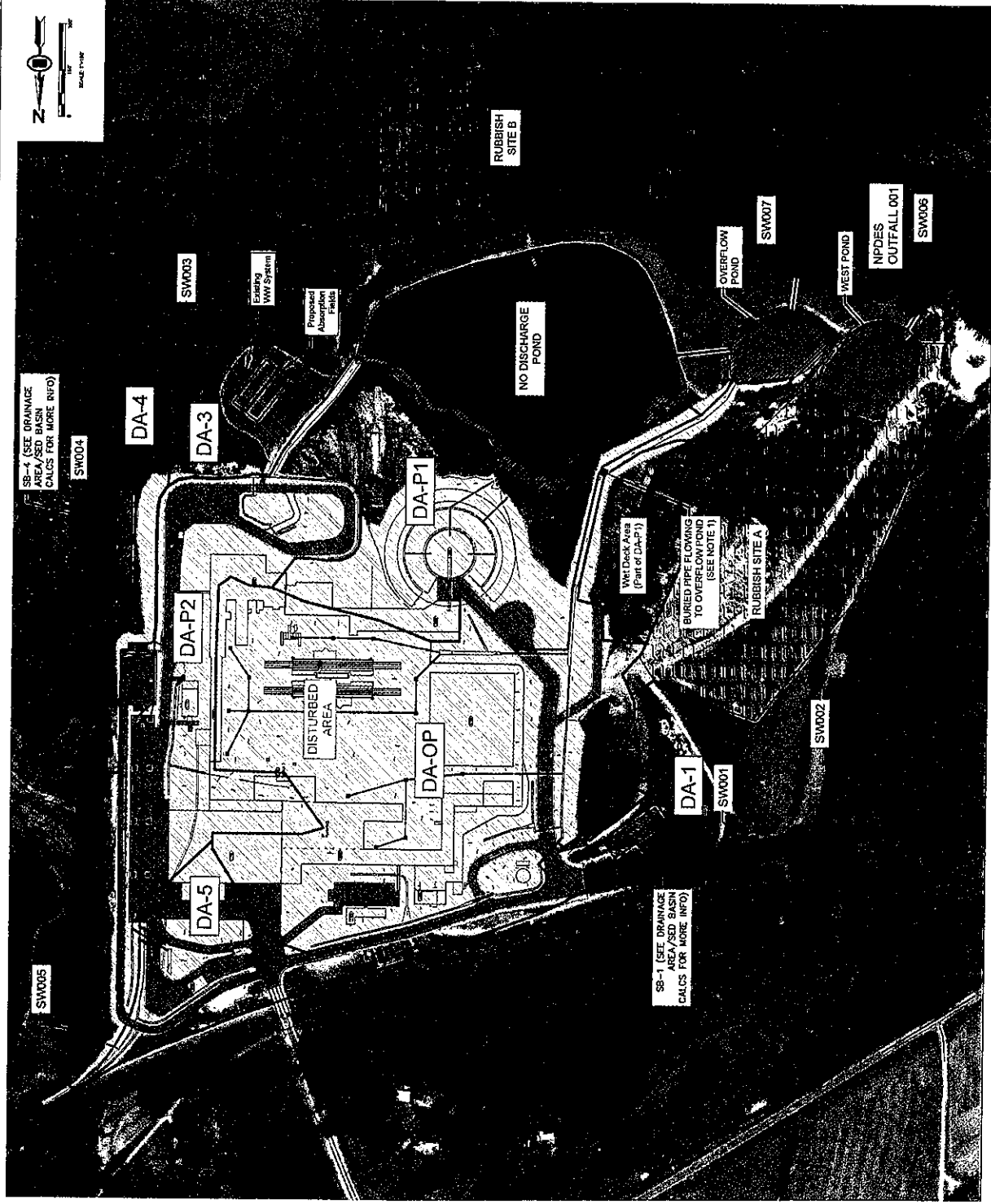
NOTES:

- 1) BURIED PIPE TO BE INSTALLED THROUGH THIS SECTION TO TRANSPORT SW DRAINAGE FROM DA-OP TO OVERFLOW POND. THIS ALLOWS WET DECK RUNOFF TO SHEET FLOW OVER THIS AREA INTO THE NO DISCHARGE POND AS PERMITTED.



LEGEND	
	Sediment Basin
	SW Outfall
	Drainage Area
	Disturbed Footprint

THIS DOCUMENT HAS BEEN MODIFIED FROM ITS ORIGINAL STATE. FOR USE ONLY AS REFERENCE WITH THE SITE STORMWATER PLAN.

**PROPOSED DRAINAGE AREAS
FIGURE 5.3**

W&SOUTH ENGINEERING CO.
MISSISSIPPI REGISTRATION # 336

OVERALL GRADING PLAN
SCALE 1" = 15'

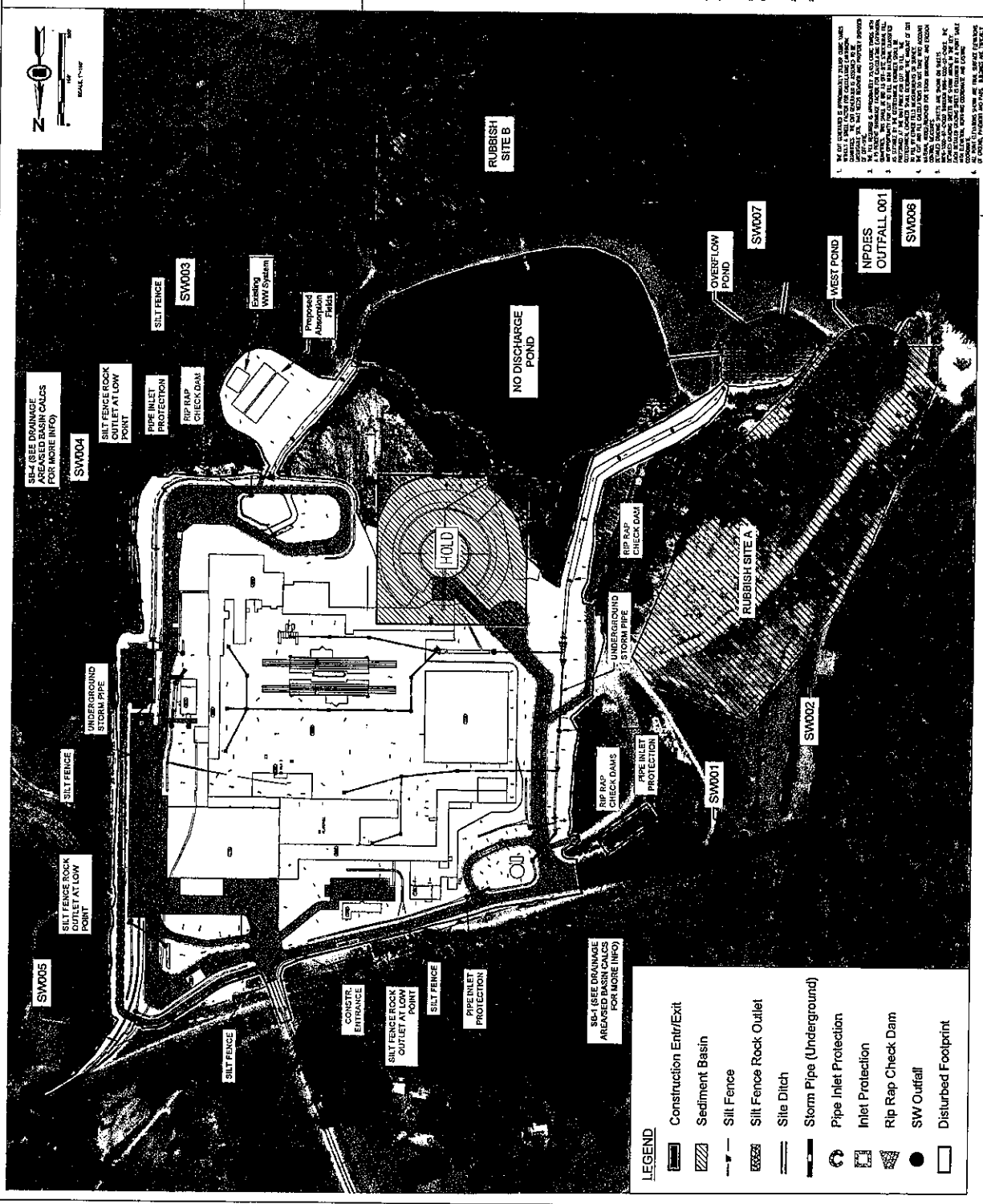
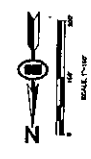

LEGEND

[Symbol]	Construction Entr/Exit
[Symbol]	Sediment Basin
[Symbol]	Silt Fence
[Symbol]	Silt Fence Rock Outlet
[Symbol]	Site Ditch
[Symbol]	Storm Pipe (Underground)
[Symbol]	Pipe Inlet Protection
[Symbol]	Inlet Protection
[Symbol]	Rip Rap Check Dam
[Symbol]	SW Outfall
[Symbol]	Disturbed Footprint

1. THE DISTURBED FOOTPRINT SHALL BE IN ACCORDANCE WITH THE DISTURBED FOOTPRINT SCHEDULE IN THE DISTURBANCE PREVENTION AND CONTROL PLAN. THE DISTURBED FOOTPRINT SHALL BE IDENTIFIED BY A HATCHED PATTERN AND SHALL BE IDENTIFIED BY A HATCHED PATTERN AND SHALL BE IDENTIFIED BY A HATCHED PATTERN.

2. THE DISTURBED FOOTPRINT SHALL BE IDENTIFIED BY A HATCHED PATTERN AND SHALL BE IDENTIFIED BY A HATCHED PATTERN AND SHALL BE IDENTIFIED BY A HATCHED PATTERN.

3. THE DISTURBED FOOTPRINT SHALL BE IDENTIFIED BY A HATCHED PATTERN AND SHALL BE IDENTIFIED BY A HATCHED PATTERN AND SHALL BE IDENTIFIED BY A HATCHED PATTERN.

4. THE DISTURBED FOOTPRINT SHALL BE IDENTIFIED BY A HATCHED PATTERN AND SHALL BE IDENTIFIED BY A HATCHED PATTERN AND SHALL BE IDENTIFIED BY A HATCHED PATTERN.

5. THE DISTURBED FOOTPRINT SHALL BE IDENTIFIED BY A HATCHED PATTERN AND SHALL BE IDENTIFIED BY A HATCHED PATTERN AND SHALL BE IDENTIFIED BY A HATCHED PATTERN.

6. THE DISTURBED FOOTPRINT SHALL BE IDENTIFIED BY A HATCHED PATTERN AND SHALL BE IDENTIFIED BY A HATCHED PATTERN AND SHALL BE IDENTIFIED BY A HATCHED PATTERN.

OVERALL GRADING PLAN
SCALE 1" = 10'

SEE AND REL. CALCULATION NOTES (5)

- (1705) ADMINISTRATION OFFICE
- (1715) FINISHED LUMBER SHED
- (1720) COOLING LUMBER SHED
- (1725) MOBILE EQUIPMENT SHOP
- (1730) TRUCK TAPPING BUILDING
- (1735) UNWINDING RACK
- (1740) PARTS STORAGE BUILDING
- (1745) NEW SCALE HOUSE
- (1750) WEST INCOMING SCALE
- (1755) WEST OUTGOING SCALE
- (1760) EAST OUTGOING SCALE
- (1765) LOC CRANE
- (1770) LOC PROCESSING BUILDING
- (1775) BARK TRUCK BIN
- (1780) SMALL BUILDING
- (1785) TRAWLER/SKIFTER
- (1790) KUM NO. 3 CONTINUOUS DRY KUM (EXISTING)
- (1795) OK 1
- (1800) OK 2
- (1805) OK 3 (FUTURE)
- (1810) PLANER/MILL BUILDING

BUILDING KEY (3)

1. ALL DISTURBED AREAS SHALL BE IN ACCORDANCE WITH THE DISTURBANCE PREVENTION AND CONTROL PLAN.
2. THE DISTURBED FOOTPRINT SHALL BE IDENTIFIED BY A HATCHED PATTERN AND SHALL BE IDENTIFIED BY A HATCHED PATTERN AND SHALL BE IDENTIFIED BY A HATCHED PATTERN.
3. THE DISTURBED FOOTPRINT SHALL BE IDENTIFIED BY A HATCHED PATTERN AND SHALL BE IDENTIFIED BY A HATCHED PATTERN AND SHALL BE IDENTIFIED BY A HATCHED PATTERN.
4. THE DISTURBED FOOTPRINT SHALL BE IDENTIFIED BY A HATCHED PATTERN AND SHALL BE IDENTIFIED BY A HATCHED PATTERN AND SHALL BE IDENTIFIED BY A HATCHED PATTERN.

GENERAL DRAWING NOTES (4)

1. THE DISTURBED FOOTPRINT SHALL BE IDENTIFIED BY A HATCHED PATTERN AND SHALL BE IDENTIFIED BY A HATCHED PATTERN AND SHALL BE IDENTIFIED BY A HATCHED PATTERN.
2. THE DISTURBED FOOTPRINT SHALL BE IDENTIFIED BY A HATCHED PATTERN AND SHALL BE IDENTIFIED BY A HATCHED PATTERN AND SHALL BE IDENTIFIED BY A HATCHED PATTERN.
3. THE DISTURBED FOOTPRINT SHALL BE IDENTIFIED BY A HATCHED PATTERN AND SHALL BE IDENTIFIED BY A HATCHED PATTERN AND SHALL BE IDENTIFIED BY A HATCHED PATTERN.
4. THE DISTURBED FOOTPRINT SHALL BE IDENTIFIED BY A HATCHED PATTERN AND SHALL BE IDENTIFIED BY A HATCHED PATTERN AND SHALL BE IDENTIFIED BY A HATCHED PATTERN.
5. THE DISTURBED FOOTPRINT SHALL BE IDENTIFIED BY A HATCHED PATTERN AND SHALL BE IDENTIFIED BY A HATCHED PATTERN AND SHALL BE IDENTIFIED BY A HATCHED PATTERN.
6. THE DISTURBED FOOTPRINT SHALL BE IDENTIFIED BY A HATCHED PATTERN AND SHALL BE IDENTIFIED BY A HATCHED PATTERN AND SHALL BE IDENTIFIED BY A HATCHED PATTERN.
7. THE DISTURBED FOOTPRINT SHALL BE IDENTIFIED BY A HATCHED PATTERN AND SHALL BE IDENTIFIED BY A HATCHED PATTERN AND SHALL BE IDENTIFIED BY A HATCHED PATTERN.
8. THE DISTURBED FOOTPRINT SHALL BE IDENTIFIED BY A HATCHED PATTERN AND SHALL BE IDENTIFIED BY A HATCHED PATTERN AND SHALL BE IDENTIFIED BY A HATCHED PATTERN.
9. THE DISTURBED FOOTPRINT SHALL BE IDENTIFIED BY A HATCHED PATTERN AND SHALL BE IDENTIFIED BY A HATCHED PATTERN AND SHALL BE IDENTIFIED BY A HATCHED PATTERN.
10. THE DISTURBED FOOTPRINT SHALL BE IDENTIFIED BY A HATCHED PATTERN AND SHALL BE IDENTIFIED BY A HATCHED PATTERN AND SHALL BE IDENTIFIED BY A HATCHED PATTERN.
11. THE DISTURBED FOOTPRINT SHALL BE IDENTIFIED BY A HATCHED PATTERN AND SHALL BE IDENTIFIED BY A HATCHED PATTERN AND SHALL BE IDENTIFIED BY A HATCHED PATTERN.
12. THE DISTURBED FOOTPRINT SHALL BE IDENTIFIED BY A HATCHED PATTERN AND SHALL BE IDENTIFIED BY A HATCHED PATTERN AND SHALL BE IDENTIFIED BY A HATCHED PATTERN.
13. THE DISTURBED FOOTPRINT SHALL BE IDENTIFIED BY A HATCHED PATTERN AND SHALL BE IDENTIFIED BY A HATCHED PATTERN AND SHALL BE IDENTIFIED BY A HATCHED PATTERN.
14. THE DISTURBED FOOTPRINT SHALL BE IDENTIFIED BY A HATCHED PATTERN AND SHALL BE IDENTIFIED BY A HATCHED PATTERN AND SHALL BE IDENTIFIED BY A HATCHED PATTERN.
15. THE DISTURBED FOOTPRINT SHALL BE IDENTIFIED BY A HATCHED PATTERN AND SHALL BE IDENTIFIED BY A HATCHED PATTERN AND SHALL BE IDENTIFIED BY A HATCHED PATTERN.
16. THE DISTURBED FOOTPRINT SHALL BE IDENTIFIED BY A HATCHED PATTERN AND SHALL BE IDENTIFIED BY A HATCHED PATTERN AND SHALL BE IDENTIFIED BY A HATCHED PATTERN.
17. THE DISTURBED FOOTPRINT SHALL BE IDENTIFIED BY A HATCHED PATTERN AND SHALL BE IDENTIFIED BY A HATCHED PATTERN AND SHALL BE IDENTIFIED BY A HATCHED PATTERN.
18. THE DISTURBED FOOTPRINT SHALL BE IDENTIFIED BY A HATCHED PATTERN AND SHALL BE IDENTIFIED BY A HATCHED PATTERN AND SHALL BE IDENTIFIED BY A HATCHED PATTERN.
19. THE DISTURBED FOOTPRINT SHALL BE IDENTIFIED BY A HATCHED PATTERN AND SHALL BE IDENTIFIED BY A HATCHED PATTERN AND SHALL BE IDENTIFIED BY A HATCHED PATTERN.
20. THE DISTURBED FOOTPRINT SHALL BE IDENTIFIED BY A HATCHED PATTERN AND SHALL BE IDENTIFIED BY A HATCHED PATTERN AND SHALL BE IDENTIFIED BY A HATCHED PATTERN.

NOTES FROM GEOTECHNICAL REPORT (5)

THIS DOCUMENT HAS BEEN MODIFIED FROM ITS ORIGINAL STATE. FOR USE ONLY AS REFERENCE WITH THE SITE STORMWATER PLAN.

BMP MAP - INTERMEDIATE/ FINAL CONTROLS

FIGURE 5.4

MISSISSIPPI ENGINEERING CO.
MISSISSIPPI REGISTRATION # 548

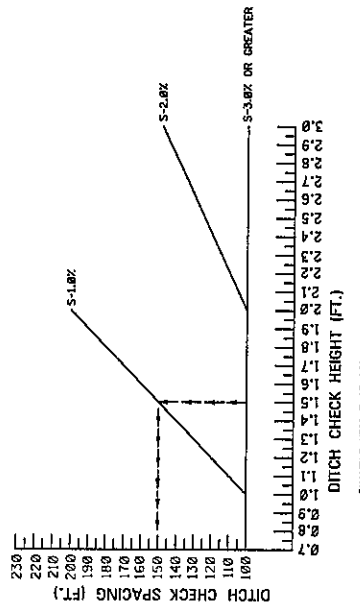

DITCH CHECK SPACING

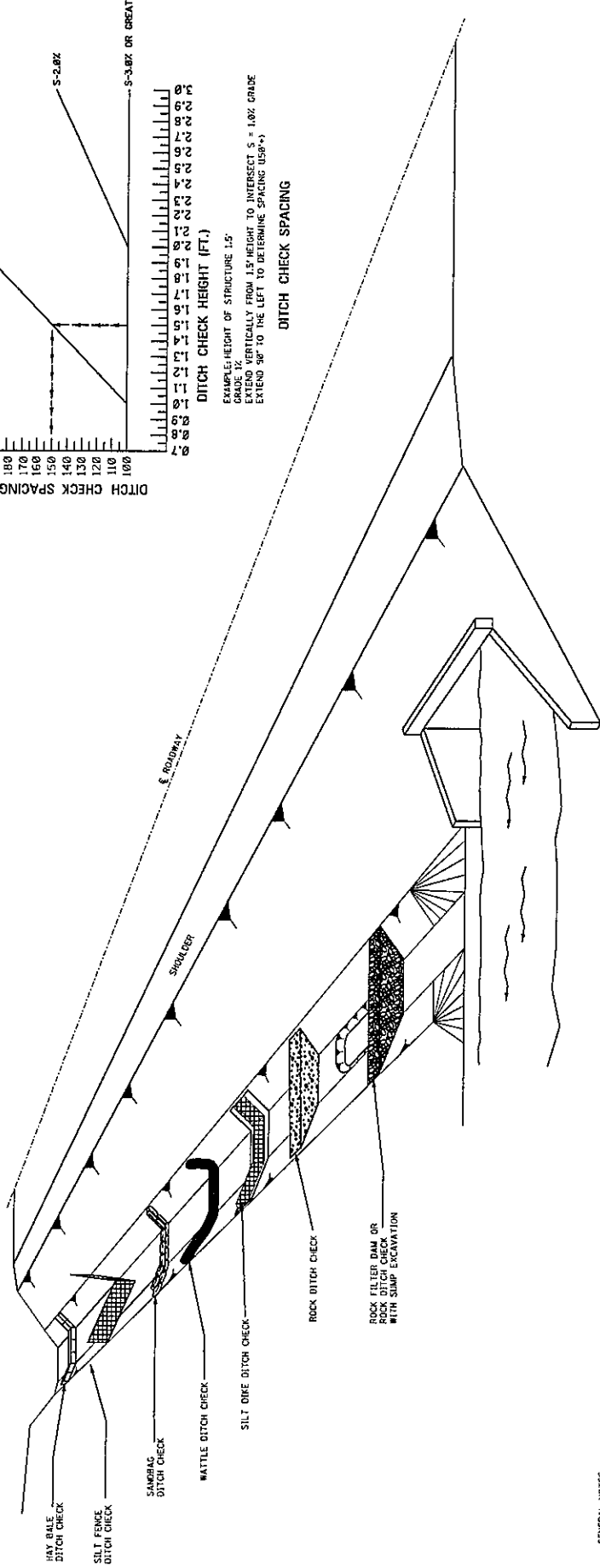

GENERAL NOTES:

1. THE DITCH CHECK PERSPECTIVE ILLUSTRATES A TOOL BOX OF TEMPORARY PRACTICES THAT MAY BE USED. DITCH CHECKS ARE INSTALLED TO CONTROL RUNOFF VELOCITY AND THUS REDUCE EROSION AND PROVIDE FOR TRAPPING OF SEDIMENTS.
2. SELECTION OF THE APPROPRIATE DITCH CHECK SHOULD BE A FUNCTION OF CONSTRUCTION PHASE, DRAINAGE AREA, DITCH GRADIENT, SOIL TYPE, ECONOMY AND SAFETY.
3. DITCH CHECKS CAN BE REMOVED FOR MAINTENANCE AND/OR REPLACEMENT BUT MUST REMAIN IN PLACE UNTIL UPLOUSE. REMOVAL OF DITCH CHECKS SHOULD BE DONE CAREFULLY TO PREVENT EROSION AND TO BEGINNING WHEN SEDIMENT ACCUMULATION REACHES 1/2 THE CAPACITY OF THE DITCH CHECK. NEVER ALLOWING FOR SEDIMENT TO ACCUMULATE MORE THAN 1/2 THE VOLUME OR HEIGHT OF THE DITCH CHECK STRUCTURE.
4. HAY BALES SHOULD BE USED TO INTERCEPT LOW VOLUME FLOWS IN LOW TO MODERATE GRADIENT DITCHES.
5. SILT FENCE DITCH CHECKS SHOULD BE USED WHERE IT HAS BEEN DETERMINED THAT HAY BALE CHECKS ARE INADEQUATE. SILT FENCE DITCH CHECKS SHOULD BE USED TO INTERCEPT LOW VOLUME FLOWS IN LOW TO MODERATE GRADIENT DITCHES.
6. SANDBAG DITCH CHECKS SHOULD BE USED FOR VELOCITY REDUCTION AND MINIMAL SEDIMENT TRAPPING IN CONCRETE PAVED DITCHES OR IN DITCHES THAT HAVE ROCK BOTTOMS.
7. WATTLE DITCH CHECKS CAN BE USED FOR VELOCITY REDUCTION AND CONTROL OF SEDIMENT TRANSPORT UNDER LOW TO MEDIUM FLOW CONDITIONS.
8. SILT DIKES CAN BE USED IN DITCHES WITH CONCENTRATED FLOWS WITHIN THE CLEAR ZONE WHERE RIPRAP CAN NOT BE USED AS CONSTRUCTION PROGRESSES.
9. ROCK DITCH CHECKS WITH SUMP EXCAVATION CAN BE PLACED IN DITCHES TO ASSURE ON-SITE SEDIMENT TRAPPING REQUIREMENTS ARE MET. DITCH CHECKS WITH SUMP EXCAVATION ARE ONLY TO BE USED IN DITCHES RECEIVE DRAINAGE FROM CUT OR FILL SLOPES OR OTHER CRITICAL AREAS WHERE SOIL EROSION IS EXPECTED. DRAINAGE AREA FOR A TEMPORARY SEDIMENT TRAP SHOULD BE LIMITED TO 3 ACRES. THEY CAN BE USED IN SERIES TO INCREASE ON-SITE SEDIMENT TRAPPING EFFICIENCY.
10. DITCH CHECKS, IN NO CASE, SHALL BE PLACED IN LIVE STREAMS.
11. CONFIGURATION AND SPACING MAY BE ADJUSTED IF APPROVED BY THE ENGINEER TO ACCOMMODATE TRAVELWAY SAFETY, WATER FLOW, OR SOIL AND INSTALLATION CHALLENGES.

MISSISSIPPI DEPARTMENT OF TRANSPORTATION
ROADWAY DESIGN DIVISION
STANDARD PLAN

**DITCH CHECK STRUCTURES,
TYPICAL APPLICATIONS
AND DETAILS**

NO.	REVISION	DATE

ISSUE DATE: AUGUST 01, 2017

PROJECT NUMBER: ECD-4
SHEET NUMBER: 6104

STATE	PROJECT NO.
MISS.	

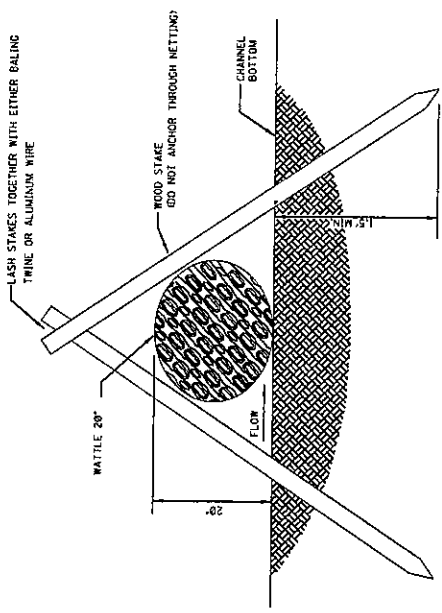

SECTION A-A

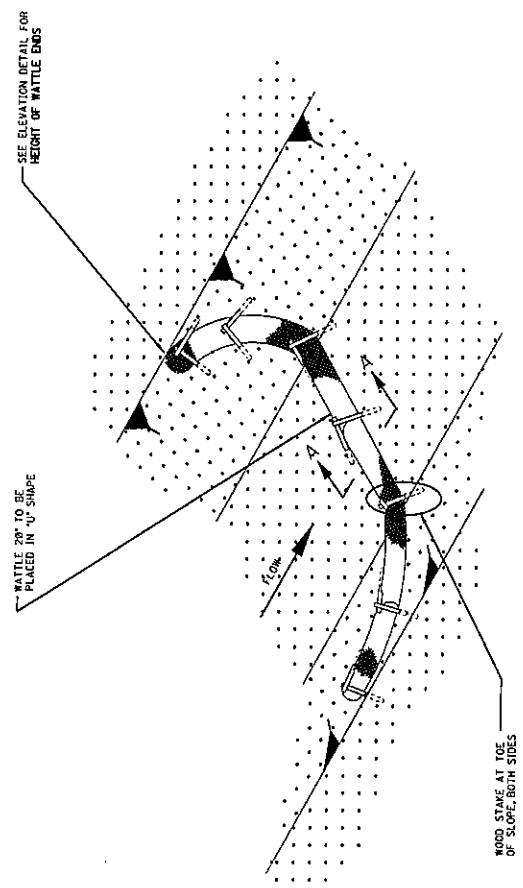

DETAIL (DITCH CHECK)

NOTE: END POINTS 'A' SHALL BE HIGHER THAN FLOWLINE POINT 'B'.

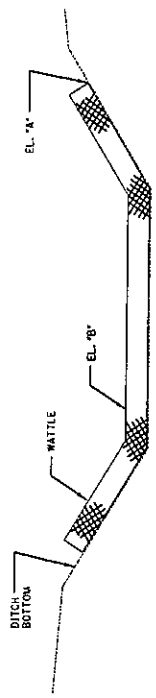

ELEVATION DETAIL

NOTES:

1. WATTLE DITCH CHECKS CAN BE USED FOR VELOCITY REDUCTION AND CONTROL OF SEDIMENT TRANSPORT UNDER LOW TO MEDIUM FLOW CONDITIONS.
2. THE PLACEMENT INTERVAL BETWEEN WATTLE DITCH CHECKS SHALL BE 100' UNLESS SHOWN OTHERWISE ON THE PLANS OR EROSION CONTROL PLAN APPROVED BY THE ENGINEER. SEE SPACING GUIDANCE ON WK. NO. ECD-4.
3. ANCHORING WOOD STAKES SHALL BE SIZED, SPACED, DRIVEN AND BE OF A MATERIAL THAT EFFECTIVELY SECURES THE CHECK. STAKE SPACING SHALL BE A MAXIMUM OF THREE FEET. ALL NON-DEGRADABLE MATERIALS SHALL BE REMOVED WHEN NO LONGER NEEDED.
4. TRENCHING OF WATTLES MAY BE NECESSARY IF PIPING BECOMES EVIDENT.
5. WATTLES SHOULD NOT BE USED IN HARD BOTTOM CHANNELS.
6. IN THE EVENT WATTLES CANNOT BE SECURED IN PLACE USING WOOD STAKES SAND BAGS MAY BE USED TO HOLD WATTLES IN PLACE TO SECURE THE WATTLES IN PLACE. IF SANDS BAGS ARE USED IN THIS APPLICATION THEY WILL NOT BE A SEPARATE PAY ITEM.

MISSISSIPPI DEPARTMENT OF TRANSPORTATION
ROADWAY DESIGN DIVISION
STANDARD PLAN

DETAILS OF EROSION CONTROL WATTLE DITCH CHECK

DATE	REVISION

ISSUE DATE: AUGUST 01, 2017
SHEET NUMBER 6106

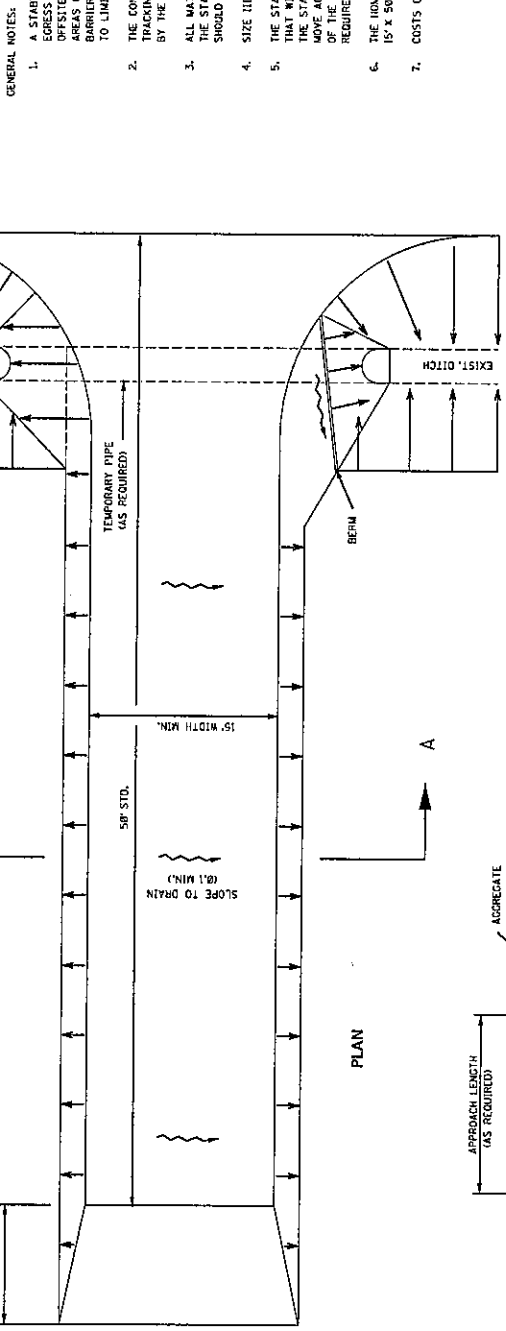

PLAN

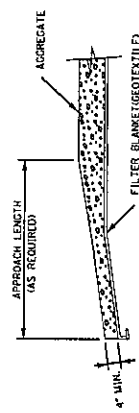

TRANSITION DETAIL

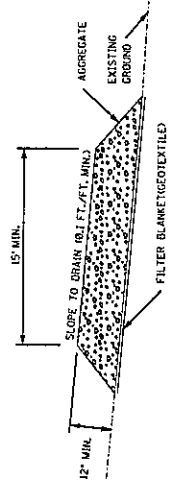

SECTION A-A

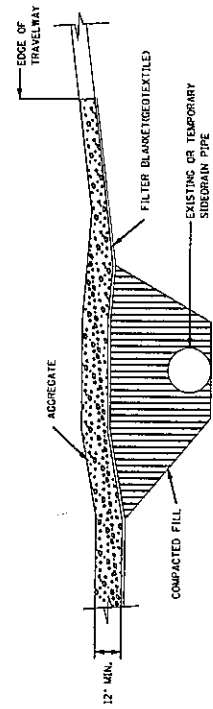

RURAL CONNECTION DETAIL

- GENERAL NOTES:
1. A STABILIZED CONSTRUCTION ENTRANCE SHALL BE CONSTRUCTED AT POINTS OF EGRESS FROM UNSTABILIZED AREAS OF THE PROJECT TO PUBLIC ROADS WHERE OFFSITE TRACKING OF MUD COULD OCCUR. TRAFFIC FROM UNSTABILIZED AREAS OF THE PROJECT SHALL BE DIRECTED THRU THE STABILIZED ENTRANCE. BARRIERS, FLAGGING OR OTHER POSITIVE MEANS SHALL BE USED AS REQUIRED TO LIMIT AND DIRECT VEHICULAR EGRESS ACROSS THE STABILIZED ENTRANCE.
 2. THE CONTRACTOR MAY PROPOSE AN ALTERNATIVE TECHNIQUE TO MINIMIZE OFFSITE TRACKING OF SEDIMENT. THE ALTERNATIVE MUST BE REVIEWED AND APPROVED BY THE ENGINEER PRIOR TO ITS USE.
 3. ALL MATERIALS SPILLED, DROPPED OR TRACKED ONTO PUBLIC ROADS (INCLUDING THE STABILIZED CONSTRUCTION ENTRANCE AGGREGATE AND CONSTRUCTION MUD) SHOULD BE REMOVED DAILY OR MORE FREQUENTLY IF SO DIRECTED BY THE ENGINEER.
 4. SIZE III STABILIZER AGGREGATE OR LARGER SHALL BE USED.
 5. THE STABILIZED CONSTRUCTION ENTRANCE SHALL BE MAINTAINED IN A CONDITION THAT WILL ALLOW IT TO PERFORM ITS FUNCTION TO PREVENT OFFSITE TRACKING. THE STABILIZED CONSTRUCTION ENTRANCE SHOULD BE RINSED WHEN NECESSARY TO MOVE ACCUMULATED MUD DOWNWARD THRU THE STONE. ADDITIONAL STABILIZATION OF THE VEHICULAR ROUTE LEADING TO THE STABILIZED ENTRANCE MAY BE REQUIRED TO LIMIT THE MUD TRACKED.
 6. THE NOMINAL SIZE OF A STANDARD STABILIZED CONSTRUCTION ENTRANCE IS 15' X 50' UNLESS OTHERWISE SHOWN IN THE EROSION CONTROL PLAN.
 7. COSTS OF ALL ITEMS ON THIS SHEET SHALL BE INCLUDED IN OTHER ITEMS BID.

MISSISSIPPI DEPARTMENT OF TRANSPORTATION
ROADWAY DESIGN DIVISION
STANDARD PLAN

CONSTRUCTION ENTRANCE

ISSUE DATE: AUGUST 01, 2017

SHEET NUMBER: 6116

PLAN VIEW

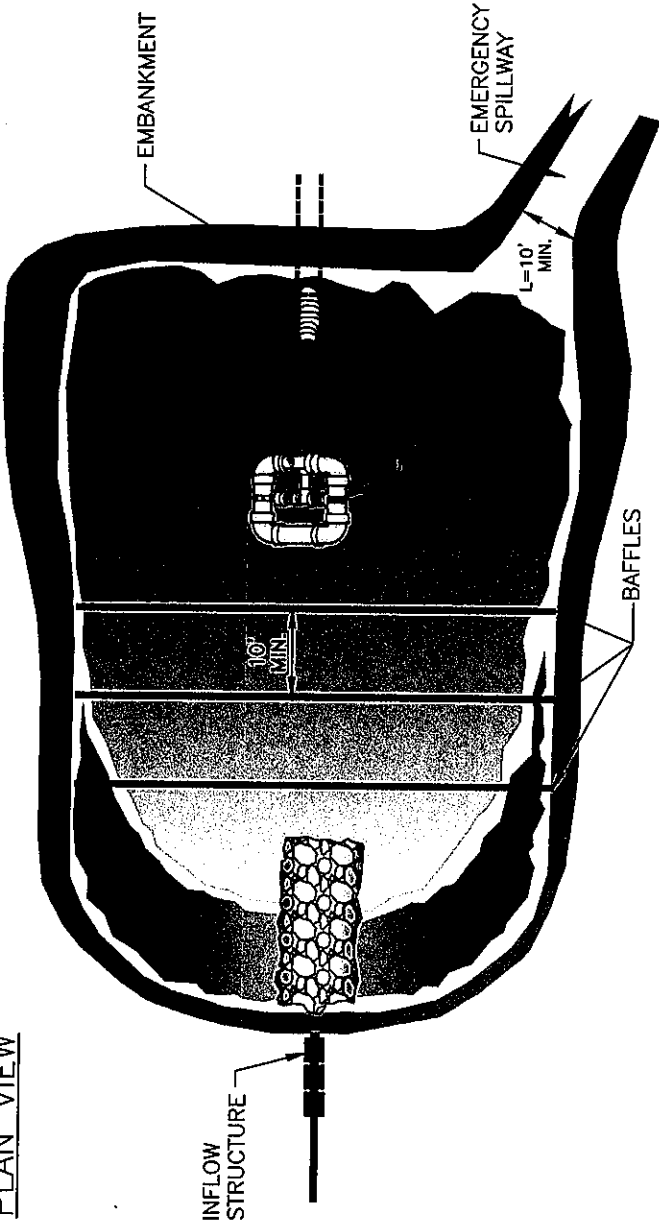

CROSS-SECTION VIEW

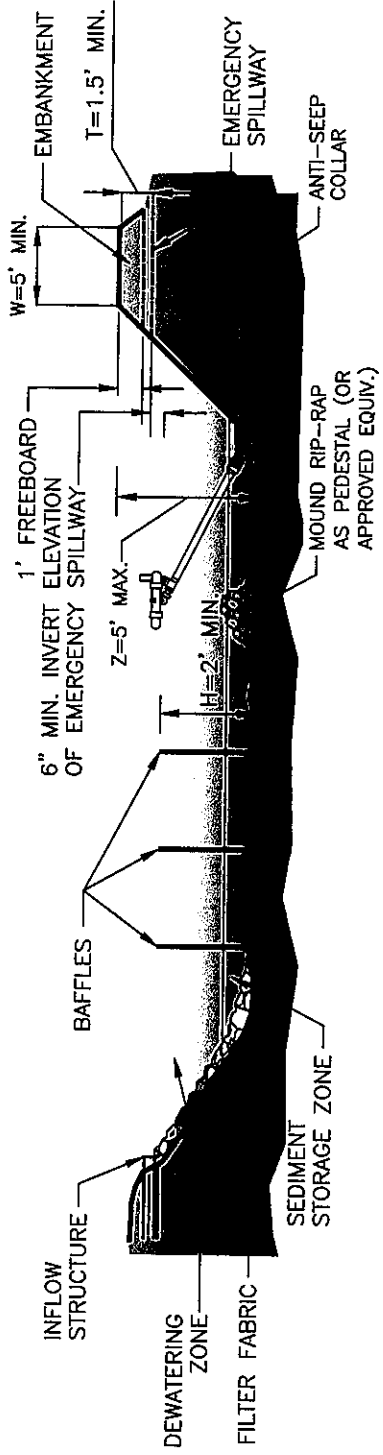

NOT TO SCALE

SEDIMENT BASIN WITH SKIMMER DETAIL

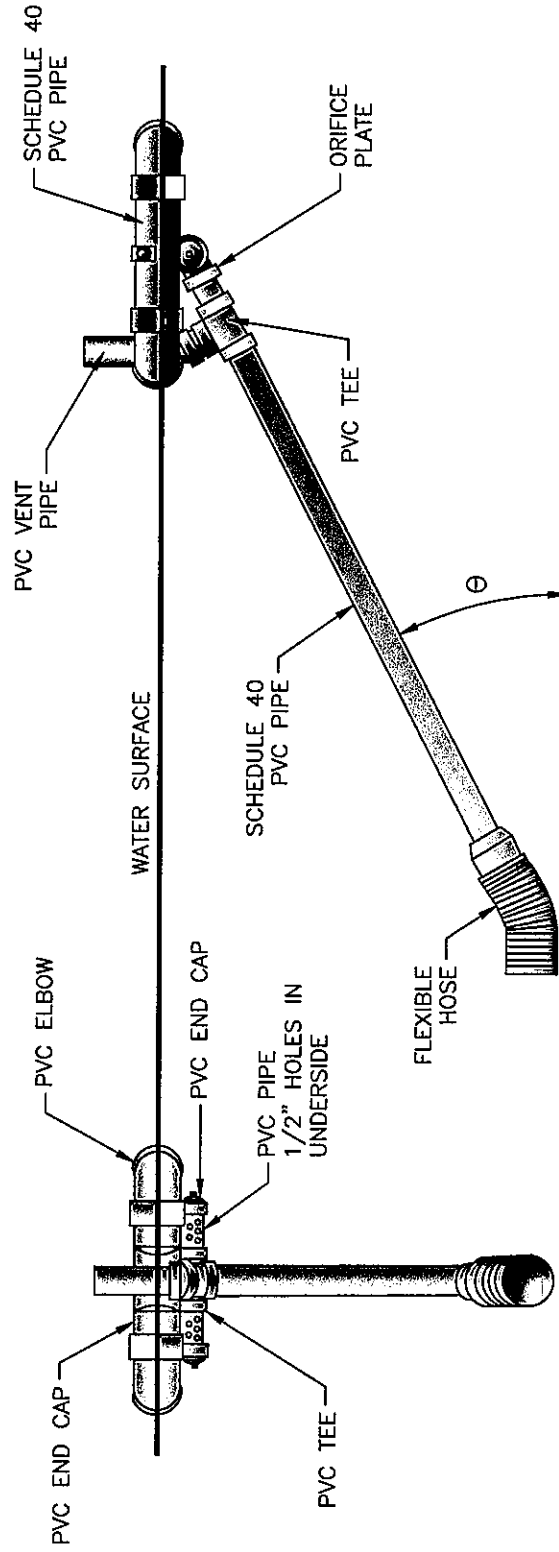
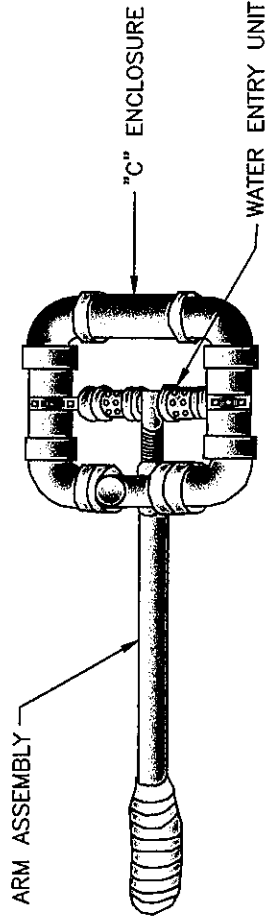

NOT TO SCALE

SKIMMER DETAIL

Worksheet 1: Materials Exposed to Stormwater

Worksheet 1
Materials Exposed to Stormwater

Material: Silt and soil from site ground work.

Purpose: Clearing and grading areas of site to construct a woodwaste rubbish landfill / Cut & Fill operations for mill upgrades throughout the site.

Location: Cut/fill operations will take place in the northeast corner of the property around the mill area, landfill clearing and grading will take place in the south section of the property south of the No Discharge Pond and west of the mill area.

Quantity Used: Varies **Produced:** N/A **Stored:** N/A

Quantity Exposed to Stormwater in Past 3 Years: N/A

Past Significant Spill or Leak Exposed to Stormwater: No

If "Yes", Describe:

Method of Storage or Disposal: N/A

Description of Material Management Practice: Best management practices used for clearing, site work and construction. Silt fences used to stabilize soil prone to erosion.

Material: Off-road Diesel fuel, hydraulic oil, lubrication oil and motor oil.

Purpose: Fueling and maintenance of on-site heavy equipment.

Location: Throughout the construction areas.

Quantity Used: Varies **Produced:** N/A **Stored:** Varies.

Quantity Exposed to Stormwater in Past 3 Years: Varies.

Past Significant Spill or Leak Exposed to Stormwater: No

If "Yes", Describe:

Method of Storage or Disposal: Horizontal Steel Closed Top Tanks and 55-gallon steel drums

Description of Material Management Practice: Tanks are inspected routinely to ensure that no leaks are occurring; proper fueling techniques and training to ensure that overfilling and spills are minimized or avoided; proper cleanup and remediation as needed to cleanup spills before they can impact stormwater. Secondary containment should be used for diesel/oil storage.

Material: Heavy equipment (tractors, track hoes, trenchers, etc.)
Purpose: Clearing, grading, excavation and filling of site disturbed areas shown in the Figures.

Location: Throughout the construction areas.

Quantity Used: Equipment used as needed **Produced:** N/A

Stored: On-site and used as needed

Quantity Exposed to Stormwater in Past 3 Years: Equipment is exposed.

Past Significant Spill or Leak Exposed to Stormwater: No

If "Yes", Describe:

Method of Storage or Disposal: N/A

Description of Material Management Practice: Heavy equipment is inspected routinely to check for leaking hoses or other areas of potential oil or fuel leaks. Equipment is maintained in a manner to minimize the contamination of stormwater. Required periodic preventive maintenance is performed on all heavy equipment.

Material: Concrete, construction materials

Purpose: Concrete will be used to construct foundations for the new mill structures and upgrades to existing structures. Construction materials will be used for constructing the new kilns and associated structures.

Location: Throughout the construction area.

Quantity Used: Varies, brought on site as needed **Produced:** N/A

Stored: On-site, stored in orderly piles and used as needed, covered as possible

Quantity Exposed to Stormwater in Past 3 Years: Some construction materials will be exposed to stormwater; concrete will be brought on to site as needed so as not to expose to stormwater.

Past Significant Spill or Leak Exposed to Stormwater: No

If "Yes", Describe:

Method of Storage or Disposal: N/A

Description of Material Management Practice: Construction materials will be brought on site as needed and will be stored in orderly stockpiles with silt fence surrounding the piles as needed. Concrete will only be brought on site as needed and poured while on site for foundations.

Worksheet 2: Summary of Materials Exposed to Stormwater

Worksheet 2: Summary of Materials Exposed to Stormwater

Source	Location	Outfall No.	313 Apply ?	Current BMPs
Site field work, clearing, grading, construction of woodwaste rubbish landfill	North Landfill South Landfill Mill Site	SW006 Retention pond SW003-005, No Discharge Pond	No	Routine inspections, proper site BMPs, prompt cleanup of spills, silt fences, check dams, haybales, and straw as needed to prevent erosion and runoff.
Off-road Diesel fuel, hydraulic oil, lubrication oil and motor oil.	North Landfill South Landfill Mill Site	SW006 Retention Pond SW003-005, No Discharge Pond	No	Routine inspections, proper site BMPs, prompt cleanup of spills, silt fences, check dams, haybales, and straw as needed to prevent erosion and runoff.
Heavy equipment (tractors, track hoes, trenchers, etc.)	North Landfill South Landfill Mill Site	SW006 Retention Pond SW003-005, No Discharge Pond	No	Routine inspections, proper site BMPs, prompt cleanup of spills, silt fences, check dams, haybales, and straw as needed to prevent erosion and runoff.
Concrete, construction materials	Mill Site	SW003-005, No Discharge Pond	No	Routine inspections, proper site BMPs, prompt cleanup of spills, silt fences, check dams, haybales, and straw as needed to prevent erosion and runoff.

Worksheet 3: List of Significant Spills and Leaks

Worksheet 4: Weekly Inspection Checklist

Worksheet 4: Weekly Inspection Checklist

Facility: Southeastern Timber Products – Ackerman, Mississippi		Inspector:		Date:		Page 1 of 3	
Item No.	Item	N/A	Y	N	Comments/Resolution of Problems		
SPCC AREAS							
SP-1	Are potential spill areas identified in your SPCC plan?						
SP-2	Are area-specific spill response measures prominently displayed in these areas?						
SP-3	Do previous spills in the areas appear to have been adequately addressed? If not, describe and list the outfalls that the areas drain to.						
SP-4	Are adequate supplies of spill response materials and equipment readily available?						
PETROLEUM PRODUCT AND CHEMICAL STORAGE TANKS							
TS-1	Are tanks free of excess rust or other signs of compromised tank integrity?						
TS-2	Are all pumps, valves, hoses, piping, etc., intact and operating properly?						
TS-3	Are all pumps and valves closed and/or locked when not in use?						
TS-4	Is the secondary containment system free of cracks, holes, or other breaches?						
TS-5	Are containment release valves closed and operating properly?						
TS-6	Are stormwater releases from the containment being properly documented?						
TS-7	Is water in the containment (mark N/A if no water) free of any sheen?						
DRUM STORAGE AREAS							
DS-1	Are drums stored on pallets or racks above the ground surface?						
DS-2	Are all drums within a secondary containment system?						
DS-3	Are drums and containers properly labeled as to the contents?						
DS-4	Are drums intact? If not, describe any leakage.						
DS-5	Are drums stacked or stored according to manufacturers' recommendations?						
DS-6	Are drums closed/sealed when not in use?						
DS-7	If secondary containment is provided, is the secondary containment system free of cracks, holes, or other breaches?						
DS-8	If secondary containment is provided, are containment release valves closed and operating properly?						
DS-9	If secondary containment is provided, are stormwater releases from the containment being properly documented?						
DS-10	Is stormwater (mark N/A if no water) free of any sheen?						
HOUSEKEEPING PRACTICES							
HK-1	Are waste receptacles/dumpsters kept in an orderly fashion and emptied as needed?						
HK-2	Are sanitary facilities properly maintained and has tie-in to the city system been made?						

Worksheet 4: Weekly Inspection Checklist (Continued)

Facility: Southeastern Timber Products - Ackerman, Mississippi		Inspector:		Date:		Page 2 of 3	
Item No.	Item	N/A	Y	N	Comments/Resolution of Problems		
OIL-WATER SEPARATORS							
OW-1	Are all pumps and float switches operating properly?	N/A	N/A	N/A			
OW-2	Are oil-water separators clean and free of debris and other substances?	N/A	N/A	N/A			
OW-3	[True (Y) or False (N)]: No oil is being carried over with water.	N/A	N/A	N/A			
OW-4	[True (Y) or False (N)]: No water is being carried over with oil.	N/A	N/A	N/A			
OW-5	If the facility has a mobile equipment wash-down area (if not, mark N/A), does it drain to an oil-water separator?	N/A	N/A	N/A			
OW-6	After leaving the oil-water separator (mark N/A if none), does water flow to a wastewater collection or recycle system?	N/A	N/A	N/A			
EROSION-PRONE AREAS							
ER-1	Are drainage pathways at the site free of evidence of soil erosion?						
ER-2	Are ditches and ponds onsite free of significant depths of sediment?						
ER-3	If sediment controls (for example, silt fences, rock rip rap, seeding, hay bales, etc.) are used onsite (check N/A if not), are they in good shape and operating properly?						
ER-4	Does all sediment remain onsite? If not, explain what erosion control measures could help prevent it from leaving the site.						
ER-5	Are structural practices such as silt fence, straw bale barrier, slope breaks, etc. in place? If not, indicate need.						
ER-6	Are any in need of revegetating? Consider need for mulching, permanent seeding, tillage, fertilizer, etc.						
STORMWATER CONTROLS							
SW-1	Are inlets, pipes, ditches, and ponds (check N/A if none) free of excess sediment?						
SW-2	Are inlets, pipes, ditches, and ponds (check N/A if none) free of debris, raw materials, waste materials, oil sheen, and other possible contaminants?						
SW-3	If outfalls leaving property are flowing during dry weather (check N/A if none are flowing), is flow due to permitted non-stormwater discharge? If not, describe source of flow (for example, groundwater, unpermitted non-stormwater discharge, etc.).						
SW-4	Are haybales, silt fences, sediment traps, or screens over inlets and culverts in place as appropriate, and are they performing as designed?						
STORAGE AREAS EXPOSED TO STORMWATER							
SA-1	[True (Y) or False (N)] None of the following is exposed to stormwater onsite: Section 313 chemicals, treated lumber, coal piles, salt piles, formal or informal landfills. If False, describe which are exposed to stormwater.	N/A	N/A	N/A			
SA-2	Are stored materials prevented from reaching inlets, pipes, ditches, or ponds?						

Worksheet 4: Weekly Inspection Checklist (Continued)

Facility: Southeastern Timber Products – Ackerman, Mississippi		Inspector:		Date:		Page 3 of 3	
Item No.	Item	N/A	Y	N	Comments/Resolution of Problems		
LOADING/UNLOADING AREAS							
LU-1	Do previous spills in the areas appear to have been adequately addressed? If not, describe and list the outfalls that the areas drain to.						
LU-2	Is the area free of waste materials, debris, and spills?						
LU-3	Are standard loading/unloading procedures being followed in the loading areas?						
LU-4	If there is a local drain (check N/A if none), is it free from obstructions?						
TRANSFORMERS							
XF-1	Are all transformers intact and free of leaking oil?						
XF-2	If evidence of leak is found (mark N/A if not), is it absent from the concrete pad or the ground below? (If spill is present on the pad or ground, report immediately to Environmental Coordinator.)						
RAIN WATER MEASUREMENTS/INSPECTIONS							
RW/I-1	Is the Rain Gauge functioning properly, and are measurements being recorded?						
Note: N/A = Not Applicable							

**APPENDIX A: State Stormwater Large Construction Notice of Intent &
General Permit**



*State of Mississippi
Department of Environmental Quality
Office of Pollution Control*

Certificate of Permit Coverage

under Mississippi's Large Construction Storm Water General NPDES Permit

Be it known

Southeastern Timber Products, LLC
Ackerman, Mississippi

having submitted an acceptable Construction Notice of Intent, is hereby granted this Certificate of Permit Coverage in order to discharge storm water associated with the construction of

Southeastern Timber Products/Tolko Landfill Construction and Mill Modification
Receiving Stream: Yockanookany River
Choctaw County

Coverage No: MSRI07471
Date of Coverage: August 17, 2022
Date Permit Expires: January 31, 2027
Date Coverage Modified: May 19, 2023

Kristal Rudolph
Chief, Environmental Permits Division



*State of Mississippi
Department of Environmental Quality
Office of Pollution Control*

Certificate of Permit Coverage

under Mississippi's Large Construction Storm Water General NPDES Permit

Be it known

**Southeastern Timber Products, LLC
Jackson, Mississippi**

having submitted an acceptable Construction Notice of Intent, is hereby granted this Certificate of Permit Coverage in order to discharge storm water associated with the construction of

**Southeastern Timber Products LLC, Ackerman Plant
Receiving Stream: Yockanookany River
Choctaw County**

Coverage No: **MSR107471**
Date of Coverage: **September 5, 2017**
Date General Permit Expires: **December 31, 2021**

2014 GNP20170001

Chief, Environmental Permits Division



State of Mississippi
Mississippi Department of Environmental Quality (MDEQ)



**LARGE CONSTRUCTION GENERAL PERMIT
FOR LAND DISTURBING ACTIVITIES OF FIVE (5) OR MORE ACRES**

THIS CERTIFIES THAT

PROJECTS ISSUED A CERTIFICATE OF COVERAGE UNDER THIS PERMIT ARE GRANTED PERMISSION TO DISCHARGE STORM WATER FROM REGULATED CONSTRUCTION ACTIVITIES INTO STATE WATERS

in accordance with effluent limitations, inspection requirements and other conditions set forth in herein. This permit is issued in accordance with the provisions of the Mississippi Water Pollution Control Law (Section 49-17-1 et seq., Mississippi Code of 1972), and the regulations and standards adopted and promulgated thereunder, and under authority granted pursuant to Section 402(b) of the Federal Water Pollution Control Act.

Mississippi Environmental Quality Permit Board

Kristal Rudolph
Authorized Signature

Mississippi Department of Environmental Quality

Issued: February 4, 2022

Permit No. MSR10

Expires: January 31, 2027

AI# 24066

APPENDIX B: Records of Weekly and Other Inspections

APPENDIX C: Records of Significant Spills and Leaks

**APPENDIX D: Mississippi SWPPP Guidance Manual
For Construction Activities**

MISSISSIPPI
STORM WATER POLLUTION
PREVENTION PLAN (SWPPP)
GUIDANCE MANUAL
FOR CONSTRUCTION
ACTIVITIES



*General Permits Branch
Office of Pollution Control
Mississippi Department of Environmental Quality
P. O. Box 2261
Jackson, Mississippi 39225
December 2016*

TABLE OF CONTENTS

	<u>Page</u>
INTRODUCTION	3
PART I COLLECT SITE INFORMATION.....	4
PART II CHOOSE CONTROLS.....	5
PART III PREPARE SWPPP	16
PART IV APPLY FOR PERMIT COVERAGE.....	18
PART V IMPLEMENT CONTROLS	18
PART VI STABILIZE SITE & TERMINATE COVERAGE	18
SAMPLE STORM WATER POLLUTION PREVENTION PLAN (SWPPP).....	19
SAMPLE SITE MAP.....	20
SAMPLE STORM WATER POLLUTION PREVENTION PLAN FOR INDIVIDUAL LOTS IN A RESIDENTIAL SUBDIVISION	21
INDIVIDUAL RESIDENTIAL LOT SWPPP SAMPLES	23
WORKSHEET 1 – CHECKLIST SHEET FOR EROSION & SEDIMENT CONTROLS	24
FREQUENTLY ASKED QUESTIONS.....	26

CHARTS

CHART 1 - SEEDING CHART FOR THE STATE OF MISSISSIPPI.....	7
---	---

This manual is primarily derived from Chapters 2, 3 and 4 of EPA's "Storm Water Management for Construction Activities, Developing Pollution Prevention Plans and Best Management Practices," September 1992, and Chapters 3, 4 and 5 of The Mississippi Department of Environmental Quality, Mississippi Soil & Water Conservation Commission and USDA Soil Conservation Service's Planning & Design Manual for the Control of Erosion, Sediment & Stormwater," April 1994. It was originally edited by Mississippi Office of Pollution Control staff Kenneth LaFleur and Louis Lavallee, and most recently by Jim Morris and Dmitriy Asanov, who thank those who reviewed and commented on the draft. See our web site for more Storm Water information at www.deq.state.ms.us.

INTRODUCTION

This document is a guide for developing a **Storm Water Pollution Prevention Plan (SWPPP)** for the Mississippi Department of Environmental Quality (MDEQ) as required in the State of Mississippi's Large and Small Construction Storm Water General NPDES Permits. The Large Construction General Permit (MSR10) authorizes storm water discharges from land disturbing activities of five (5) acres or greater; or for land disturbing activities that are part of a larger common plan of development or sale that will disturb five (5) or more acres. The Small Construction General Permit (MSR15) authorizes storm water discharges from land disturbing activities of one (1) acre to less than five (5) acres; or for land disturbing activities less than one (1) acre that are part of a larger common plan of development or sale that will disturb one (1) to less than five (5) acres. These permits must be consulted for complete requirements. For a more thorough description of erosion and sediment controls, see the most recent edition of the "**Erosion Control, Sediment Control and Stormwater Management on Construction Sites and Urban Areas (Three Volumes)**," which may be accessed electronically at:
http://deq.state.ms.us/MDEQ.nsf/page/NPS_PlanningandDesignManual2ndEd_Vol1?OpenDocument

This document is organized according to the six parts of SWPPP planning and implementation:

- **PART I** **Collect Site Information**
- **PART II** **Choose Controls**
- **PART III** **Prepare SWPPP**
- **PART IV** **Apply for Permit Coverage**
- **PART V** **Implement Controls**
- **PART VI** **Stabilize Site & Terminate Coverage**

When developing a SWPPP, always consider the following items:

- **Divert** upslope water around disturbed areas.
- **Control** storm water volume and velocity within the site
- **Disturb** the smallest area possible. Remember, by disturbing large areas that have high erosion potential, the cost of erosion and sediment controls will greatly increase.
- **Phasing-Schedule** or sequence construction activities so as to concentrate work in certain areas so as to minimize the amount of soil that is exposed at one time.
- **Preserve** existing vegetation where possible, especially trees.
- **Provide and maintain** natural buffers around surface waters.
- **Avoid** disturbing sensitive areas such as:
 - Steep and/or unstable slopes
 - Land upslope of surface waters
 - Areas with erodible soils
 - Existing drainage channels
- **Limit** exposure of disturbed areas to the shortest time possible by revegetating disturbed areas as soon as possible.
- **Minimize** the amount of cut and fill, and soil compaction.
- **Transport runoff** down steep slopes through lined channels or piping.
- **Remove sediment from storm water before it leaves the site** by allowing runoff to pond in controlled areas to drop out sediment. Filter runoff by using natural vegetation, brush barriers, silt fences or hay bales.
- **Minimize** off-site vehicle tracking of sediments.

PART I

COLLECT SITE INFORMATION

- **Existing soils information** - *Are the soils susceptible to erosion?* For information see the Natural Resources Conservation Service (NRCS) soil surveys or call the State Conservationist through the State Office in Jackson at (601) 965-5196 or 5205. The NRCS is the former Soil Conservation Service.
- **Receiving water(s)** - Identify any lakes, streams, ponds or wetlands that may receive site runoff. If sensitive water bodies are downstream (for example: wild and scenic rivers, recreational streams, natural aquatic sites, private ponds and lakes or receiving streams listed on the Impaired Water Bodies 303(d) list or segments for which a Total Daily Maximum Load (TMDL) has been approved) extra erosion controls will be needed. A discussion of the Impaired Water Bodies follows. For assistance in locating adjacent or downstream waterbodies, see the appropriate USGS Quad map(s), a photocopy of which must be submitted along with the SWPPP. To obtain USGS Quad maps contact the Mississippi Office of Geology at (601) 961-5523.
- **List of Impaired Water bodies** - Mississippi's waters are used for public water supply, shell fish harvesting, recreation, and fishing & aquatic life support. The MDEQ assesses State waters every two years to determine if their uses are supported. A water body is said to be impaired when its use is partially or non-supportive. Construction sites, whose receiving streams that are on the list of impaired waters due to siltation, suspended solids, sediment, turbidity or habitat alterations, require additional erosion and sediment controls. These additional controls are intended to ensure that sediment will not further impact those impaired waters. Impaired waters are issued TMDLs, which represent the amounts of pollutants that can enter a water body so that the water body will meet and continue to meet state water quality standards. A list of water bodies with established TMDLs and an updated list of Section 303(d) streams can be accessed at http://www.deq.state.ms.us/MDEQ.nsf/page/TWB_Total_Maximum_Daily_Load_Section?OpenDocument . For more information concerning 303(d) listed streams, please contact the Water Quality Assessment Branch of the MDEQ at (601) 961-5171.
- **U. S. Army Corps of Engineers** - If your project is rerouting, filling or crossing a water conveyance of any kind, you should contact the U. S. Army Corps of Engineers, Regulatory Branch in your area for possible permitting requirements. For information call the Vicksburg Corps District at (601) 631-7071 or the Mobile Corps District at 251-690-2658.
- **Calculating total acreage disturbed** – Total acreage disturbed includes the total area disturbed over the course of the project. For subdivisions, this includes roads, utilities, drainage and home sites. A minimum of 10,000 ft² per home site or the entire lot, if smaller, shall be included. Acreage may be determined by dividing square footage by 43,560, as demonstrated in the following example:

Convert 54,450 ft² to acres (*square footage is obtained by multiplying the length of the disturbed area by the width of the disturbed area*)

Divide 54,450 ft² by 43,560 ft² per acre:

54,450 ft² ÷ 43,560 ft²/acre = 1.25 acres
(Small construction coverage would be required for 1.25 acres of disturbance)
- **Determine drainage areas** - For each point where concentrated flow will leave the site, the drainage area should be determined. Drainage areas are portions of the site where runoff will flow in one particular direction or to a particular discharge point. This will help you select and design the appropriate sediment controls. The USGS Quad map(s) may be useful in determining drainage areas.

PART II

CHOOSE CONTROLS

Select vegetative and structural controls; housekeeping practices; post-construction/storm water management measures & controls to be used prior to, during and after land disturbing activities. The SWPPP must include a description of the measures and controls that will be used throughout the construction project. Incorporate any municipal, county or other required controls into your SWPPP.

1. **Vegetative controls** are an inexpensive and effective way to protect soil from raindrop impact, a major erosion force. It also decreases erosion due to flowing water by reducing its velocity. Roots from vegetation hold the soil in place and increase infiltration. **Topsoil should be added where existing soils are not suitable for adequate vegetative growth.** Please indicate if soil amendments are to be used.

- **Vegetative buffer zones** are undisturbed or planted vegetated areas that surround a development, land disturbance activity or that border an intermittent stream or permanent water body. Buffer zones aid in sediment filtration and removal. If possible, construction site runoff should be spread out over entire buffer zone length. A minimum 15-foot wide buffer zone is recommended. A minimum 150-foot buffer zone is recommended adjacent to perennial streams and water bodies.
- **Sod stabilization**, the most effective vegetative practice available, involves establishing long-term stands of grass with sod on exposed surfaces. Properly installed and maintained sodding can be more than 99 percent effective in reducing erosion.

- **Protection of trees** involves preserving and protecting selected trees that exist on the site prior to development. Mature trees provide extensive canopy and root systems that hold soil in place. It is important to provide tree protection to the tree drip line rather than only around the perimeter of the trunk. Shade trees also keep soils from drying rapidly and becoming susceptible to erosion, in addition to increasing property value.

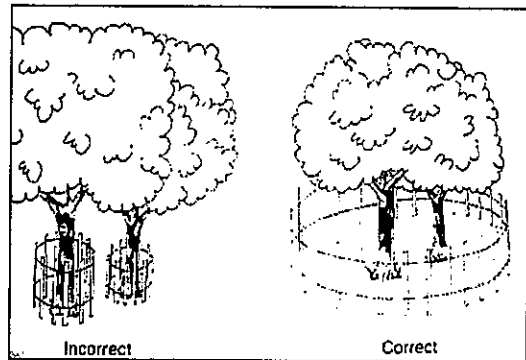

- **Tillage, with lime and fertilizer**, may be important before seeding. The Cooperative Extension Service local agent can analyze soil for lime and fertilizer needs.
- **Temporary seeding** is the planting of fast-growing annual grasses to hold the soil in areas that will not be disturbed again for 14 or more days. The appropriate temporary vegetative practices must be implemented immediately. For long term protection (greater than one year), permanent seeding should be initiated. The seeding chart on page 7 lists annuals that may be used. Mulching helps ensure seed growth and is essential when slopes are steep, weather is hot or dry and soil conditions are poor.
- **Permanent seeding** is the use of perennial grass (with trees & shrubs) to stabilize the soil. The appropriate permanent vegetative practices must be implemented immediately. The seeding chart on page 7 lists perennials that may be used. Vegetation is often not fully established until one (1) year from planting. Inspect, repair and re-seed as needed, evaluating choice of seed and quantities of lime and fertilizer. Use temporary seeding if the time of year is not appropriate for permanent seeding. Sodding may be needed in highly erodible areas.

- **Mulching** is the placement of hay, grass, wood chips, straw, or synthetic material on the soil. Mulch holds moisture, dampens temperature extremes and retards erosion on steep slopes during seed establishment. Soils that cannot be seeded due to the season should be mulched to provide temporary protection.
- **Erosion & sediment control blankets** are machine-produced mats of straw or other fibers held together with netting that provide temporary or permanent stabilization in critical areas, such as slopes or channels, so that vegetation may be established. On slopes shallower than 2:1, blankets should be laid perpendicular to the direction of flow. However, on steep slopes (> 3:1) and in areas of concentrated flows (ditches, swales, storm water conveyance channels), blankets should be laid in parallel to the direction of flow. Blankets should be anchored in a six (6) inch trench and should overlap by three (3) inches if strips are laid side by side.
- **Surface roughening** involves using heavy equipment to create grooves on bare soil in a perpendicular direction across the slope. Roughening loosens compacted soils in order to reduce runoff velocity and erosion while aiding in seed growth. Roughened slopes should be immediately seeded and mulched.
- Slopes that will be mowed should be grooved with shallow grooves 1 to 3 inches deep and no further apart than 10 to 12 inches.

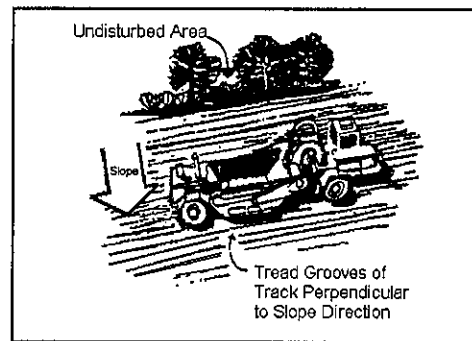

- Cut slopes that will not be mowed can either be “stair-stepped” or grooved. If stair-step grading, the horizontal portion of each step must be longer than the vertical portion and should be sloped into the vertical portion. Individual vertical cuts should be no higher than 24 inches or 36 inches if the material is rocky.

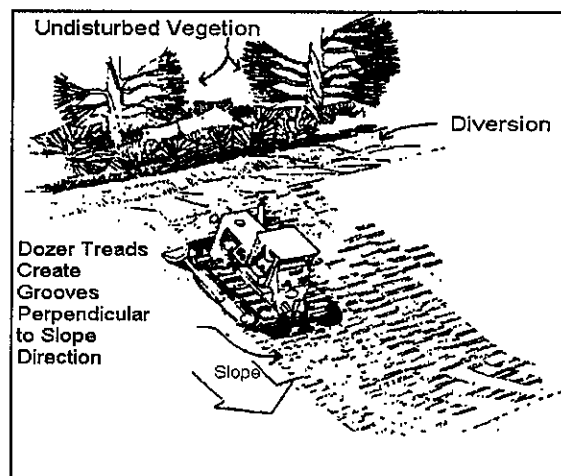

SEEDING CHART FOR THE STATE OF MISSISSIPPI

*For a more comprehensive vegetation schedule, see "Erosion Control, Sediment Control and Stormwater Management on Construction Sites and Urban Areas (Three Volumes)"

SPECIES	SEEDING RATE/ACRE	PLANTING TIME	DESIRED pH RANGE	FERTILIZATION RATE/ACRE	METHOD OF ESTABLISHMENT	ZONE OF ADAPTABILITY	NATIVE/INTRODUCED
Common Bermuda	15 lbs. alone 10 lbs. mixture	3/1 - 7/15 9/1 - 11/30	6.0 - 7.0	600 lbs. 13-13-13	seed or sod	All	Introduced *Potential for Invasiveness
Bahia	40 lbs. alone 30 lbs. mixture	3/1 - 7/15 9/1 - 11/30	6.0 - 7.0	600 lbs. 13-13-13	seed	Central & South	Introduced
Fescue	40 lbs. alone 30 lbs. mixture	9/1 - 11/30	6.0 - 7.0	600 lbs. 13-13-13	seed	North & Central	Native
Saint Augustine	--	3/1 - 7/15	6.0 - 7.0	600 lbs. 13-13-13	sod only	Central & South	Native
Centipede	4 lbs. alone 2.5 lbs. mix	3/1 - 7/15	6.0 - 7.0	600 lbs. 13-13-13	seed or sod	All	Introduced
Carpet Grass	15 lbs. alone 10 lbs. mixture	3/1 - 7/15	6.0 - 7.0	600 lbs. 13-13-13	seed or sod	All	Native
Zoysia Grass	--	3/1 - 7/15	6.0 - 7.0	600 lbs. 13-13-13	sod only	All	Introduced
Creeping Red Fescue	30 lbs. alone 22.5 lbs. mix	9/1 - 11/30	6.0 - 7.0	600 lbs. 13-13-13	seed	All	Native
Weeping Lovegrass	10 lbs. alone 5 lbs. mix	3/1 - 7/15	6.0 - 7.0	600 lbs. 13-13-13	seed	All	Introduced
Sericea Lespedeza	40 lbs.	3/1 - 7/15 9/1 - 11/30	6.0 - 7.0	400 lbs. 6-24-24	seed	All	Introduced
*Wheat	90 lbs. alone	9/1 - 11/30	6.0 - 7.0	600 lbs. 13-13-13	seed	All	Native
*Ryegrass	30 lbs.	9/1 - 11/30	6.0 - 7.0	600 lbs. 13-13-13	seed	All	Native
*White Clover	5 lbs.	9/1 - 11/30	6.0 - 7.0	400 lbs. 6-24-24	seed	All	Introduced
*Crimson Clover	15 lbs.	9/1 - 11/30	6.0 - 7.0	400 lbs. 6-24-24	seed	All	Introduced
*Hairy Vetch	30 lbs.	9/1 - 11/30	6.0 - 7.0	400 lbs. 6-24-24	seed	All	Introduced
*Browntop Millet	40 lbs. alone 15 lbs. mix	4/1 - 8/30	6.0 - 7.0	600 lbs. 13-13-13	seed	All	Introduced

*Note on Annuals. For permanent seeding, annuals can only be used in a mixture with perennials.

North-north of Hwy. 82

Central- south of Hwy. 82 & north of Hwy. 84

South- south of Hwy. 84

2. **Structural Controls** divert flows away from disturbed areas, reduce runoff velocities, filter out sediment and remove sediment by ponding. Temporary structures are installed before and during construction. After removing temporary storm water controls the area should be vegetated. Permanent structures remain after construction.

- **Diversion** ridges or channels of stabilized soil can divert off-site runoff from disturbed areas or sediment-laden runoff into sediment basins. If diversions will remain in place more than 30 days they should be covered with temporary or permanent vegetation. Diversions must have enough grade to assure drainage, but not enough

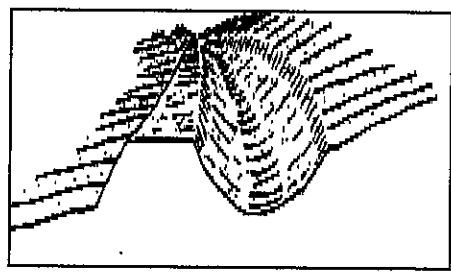
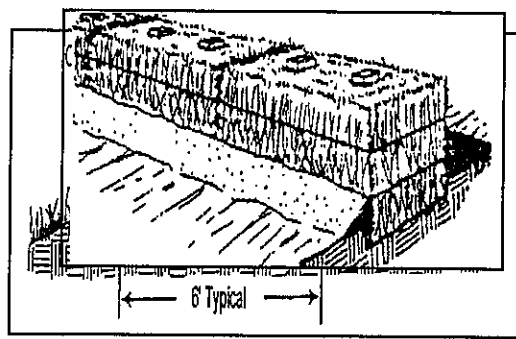

to cause erosion within the channel. Allow sufficient room around diversions to accommodate machine regrading, if needed. The maximum allowable drainage area is five acres.

- **Silt fences** are used below small disturbed areas to capture sediment from sheet flow. Eight inches of fence should be buried in a trench about four inches deep and four inches wide. **Silt fences that are not buried are improperly installed, have no useful function, are a waste of money, and could result in substantial fines.** The maximum slope length behind a fence is 100 feet with maximum gradient two horizontal to one vertical (2:1). **Under no circumstances should silt fences be installed across flowing streams.** They may be placed in minor swales or ditch lines where the maximum contributing drainage area is no more than two acres. The fence must be maintained and the sediment removed when deposits reach one-half the fence height. After the fence is no longer needed, the area should be graded, seeded and mulched.

Install fence steel fence posts or 4 inch diameter wooden posts that are five 5 feet in length. Posts should be installed starting at the center of the lowest point of the fence line and be driven 12 inches into the ground. Allow 6 inch overlap at joints. Machines that install silt fences are also acceptable methods of installation.

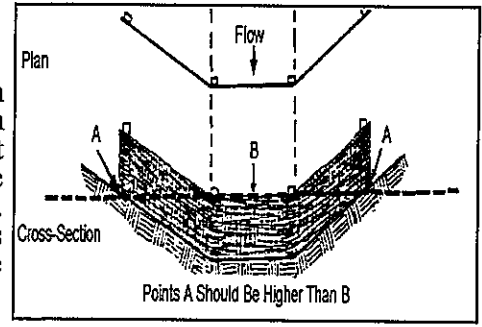

- **Straw bale barriers** are also used on small disturbed areas to capture sediment from sheet flow. The drainage area must be restricted to 1/8 acre per 100 feet of barrier. Maximum gradient behind the barrier is three horizontal to one vertical (3:1). The barrier must be located so that

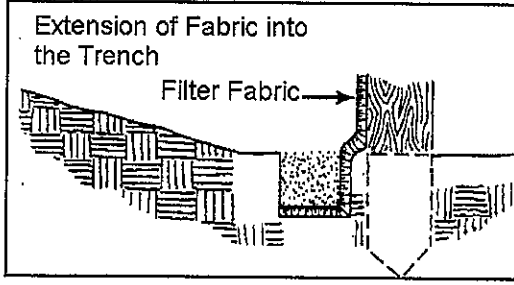

the water depth does not exceed one foot at any point. Straw bales, with bindings oriented around the sides, shall be entrenched a minimum of four inches and anchored with two stakes driven toward the previously laid bale. **Straw bales that are not buried are improperly installed, have no useful function, are a waste of money, and could result in substantial fines.**

- Bales should be placed so that the ends are tightly abutting each other. Bales should be staked down using 1" x 2" wood stakes or rebar. Use two (2) stakes per bale and angle the first stake towards the previously laid bale. Stakes should be long enough to go through the bale and into the ground a minimum of 12 inches.

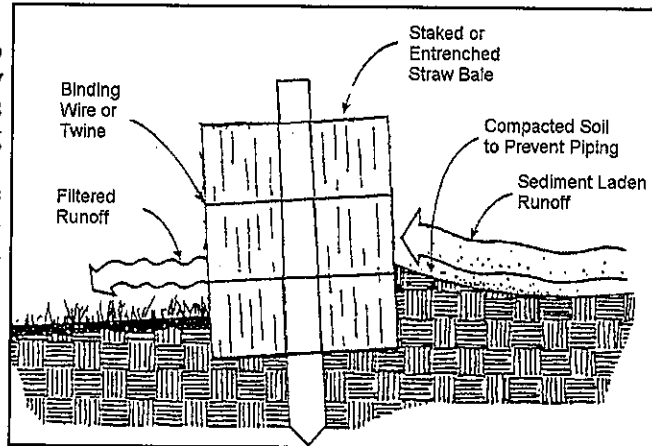

- Gaps between bales shall be wedged with straw. Loose straw scattered immediately uphill increases barrier efficiency. **Under no circumstances should straw bale barriers be constructed in live streams.** For minor dry swales, the end bale bottoms shall be higher than the middle bale top to assure runoff will not flow around the barrier. Repair damaged bales, end runs and undercutting. Remove sediment when it reaches one-half (1/2) barrier height. When upslope areas are stabilized, remove bales and grade, seed and mulch barrier line.

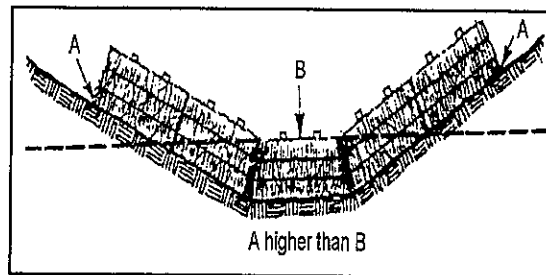

- **Storm drain inlet protection** is a sediment filter (aggregate, silt fence, straw bales, or manufactured filter) or an excavated sediment trap around a storm drain inlet. Storm sewers installed before their drainage area is stabilized can convey large amounts of sediment to streams. Straw bale and silt fence inlet protection are used for drainage areas of less than one (1) acre and slopes no greater than five percent (5%).

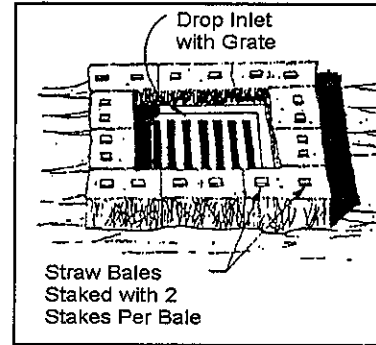
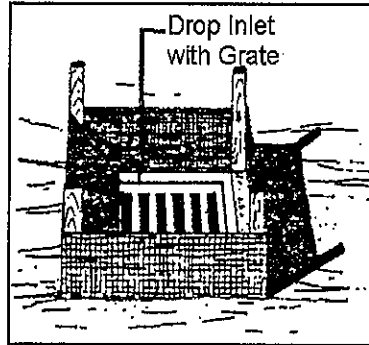

- **Sediment basins** allow sediment to settle out. Sediment basins are made by diking, excavating or a combination of the two. The "Erosion Control, Sediment Control and Stormwater Management" manual recommends a basin capacity of 134 yd³ per acre drainage area. Because of typical basin shapes and embankment side slope requirements of 2:1 or flatter, the capacity of the basin may be estimated by using the trapezoidal rule

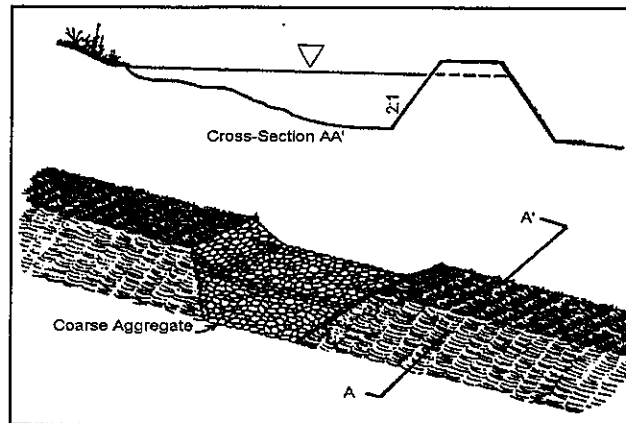

approximation of 40% x height x surface area. Sediment should be removed when the volume has been reduced to 67yd³ per acre drainage area. The length should be twice the width, with maximum surface area and outlet as far from the inlet as possible. If using a dike, it must be well compacted and vegetated, with an outlet pipe or coarse aggregate spillway. Install basins prior to construction but not in flowing streams and not in intermittent drains without a Corps of Engineers Permit. Use diversions to direct drainage to basins. Mississippi's Large Construction Storm Water General Permit requires that a sediment basin be installed in any drainage location where more than 10 acres in the upstream basin are disturbed at one time. See planning and design manual for basin design details.

- **Flocculants** may be used in order to treat turbidity in construction site storm water discharges and incorporated as a part of an overall storm water management system. If flocculant application is proposed, the SWPPP must list the proposed flocculants to be used, describe the method, frequency and location of introduction, and identify the location of BMPs where flocculated material will settle. Flocculants must meet the criteria contained in ACT8 of the Large Construction General Permit and

implemented in accordance with the manufacturer's instructions.

- **Fiber logs (also known as wattles)** are rolls made of straw or coconut fiber placed inside plastic netting. Wattles can be good for reducing slope length on steep slopes, for very low gradient sites that are small, or for preventing sediment from leaving small stockpiles. A shallow depression is scraped out where the fiber log is staked down. Wattles can be used to protect a stockpile on a hard surface where no digging can take place, in which case the fiber log is laid on the surface ensuring that all ends are abutting tightly and fastened to each other. Sandbags or concrete blocks are used on the outside to prevent movement.

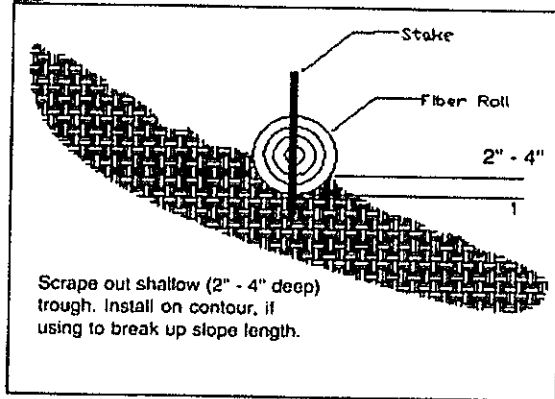

- **Slope drains** are piping or lined channels carrying storm water downslope without erosion. Runoff is directed to the drain by earthen diversion with a minimum height of 18 inches. At the inlet, the diversion and inlet cover must be six (6) inches higher than the top of the piping. The diversion and especially the inlet cover must be well compacted. Install piping hold-downs at 10-foot intervals and line the outlet area with riprap or other material to prevent scour and undermining. The maximum drainage area per drain should be five (5) acres. Permanent slope drains would be subsurface or paved flumes.

**SIZE OF SLOPE DRAIN
Maximum Drainage
Piping Diameter**

<u>Area (Acres)</u>	<u>(Inches)</u>
0.5	12
.75	15
1.5	18
2.5	21
3.5	24
5.0	30

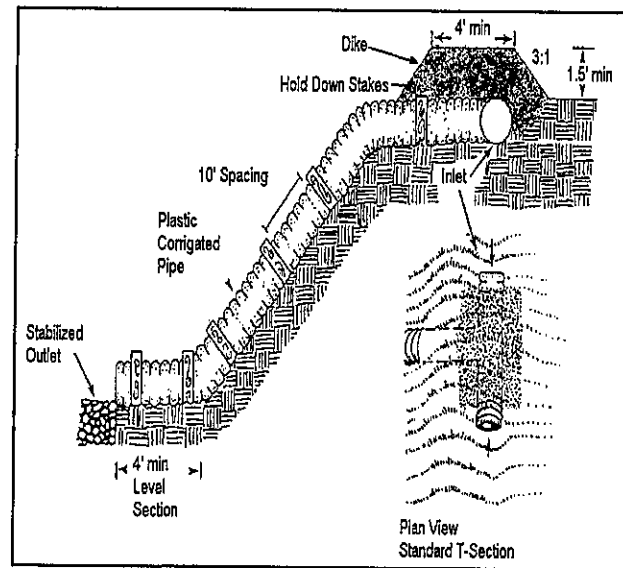

- **Slope breaks**, diversions or benches, are used to reduce the slope length of a cut or fill to minimize rill erosion and prevent gulying. Drainage area should be less than one (1) acre.

Slope Breaks	
Slopes	Spacing (ft)
Steep Slopes	
2:1	20
3:1	35
4:1	45
Gradual Slopes	
15 - 25%	50
10 - 15%	80
6 - 10%	125
3 - 6%	200
<3%	300

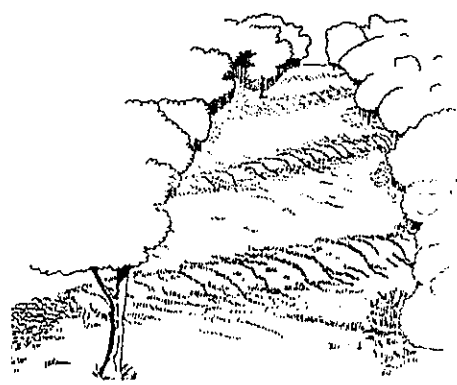

- **Riprap outlet protection** is placed at the outlet end of culverts or channels to reduce the depth, velocity and energy of water so that the flow will not erode the receiving downstream reach.

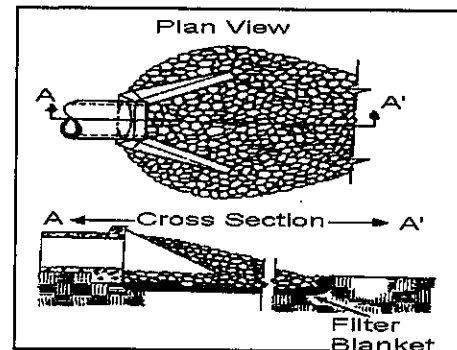

- **Check dams** are small dams constructed across swales or drainage ditches to reduce flow velocity and erosion. The purpose of a check dam is to prevent erosion of the swale or drainage ditch. They are not used in streams. Check dams can be constructed of stone, straw bales, or logs, with a maximum height of two (2) feet. **The check dam center must be at least six (6) inches lower than the outer edges to prevent erosion around the edges.**

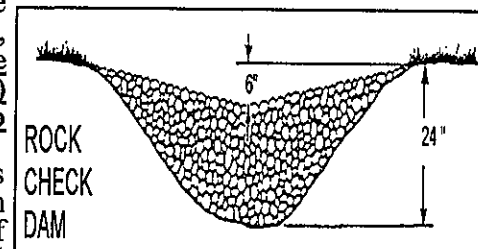

The maximum spacing between dams should be such that the toe of the upstream dam is at the same elevation as the top of the downstream dam. Sediment will accumulate and should be removed from behind the check dams when it reaches one half the dam height. Erosion around dam edges should be corrected immediately, ensuring that the dam center is six (6) inches lower than the edges. In grass-lined ditches, grass must be established prior to dam removal. The dam site should be seeded and mulched or sodded, as needed. The use of check dams should be limited to small open channels that drain 10 acres or less.

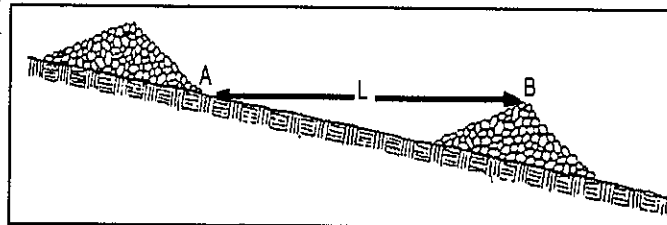

- **Construction entrance/exits** are stone stabilized site entrances which reduce sediment transferred onto public roads. Aggregate should be at least six (6) inches thick and 50 feet long. Tire washing may also be needed.

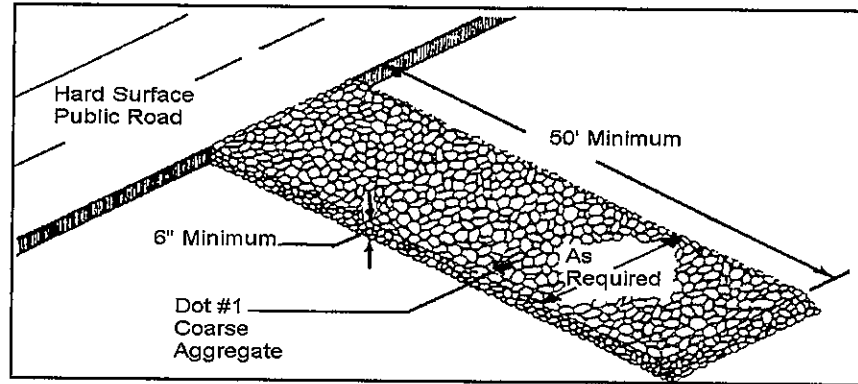

- **Level spreaders** are diversion outlets allowing the flow to disperse uniformly over surrounding vegetated areas. Spreaders should be constructed on undisturbed soil with downstream areas having established vegetation. Used to divert upslope waters around disturbed areas.

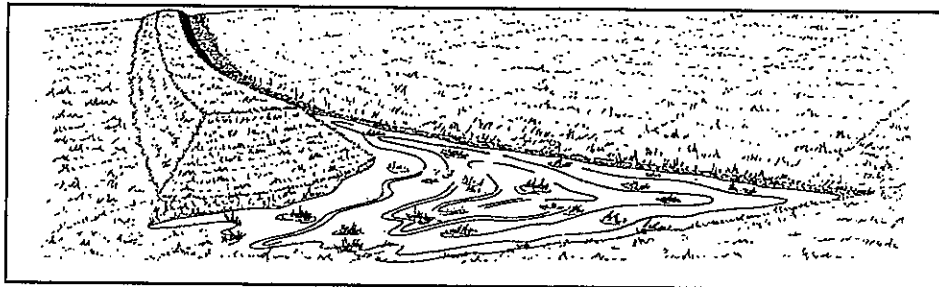

3. **Controls for individual lots in subdivisions and commercial developments.** The Large Construction Storm Water General Permit specifies that individual lots within residential and commercial developments, “that are part of a larger common plan of development or sale” are regulated regardless of size or owner. Therefore, requirements have been established for commercial and residential lots regarding storm water pollution prevention for lots and parcels that are sold by the original coverage recipient.

Commercial development: The original coverage recipient responsible for all construction activities until individual lots or parcels within the development are sold to others and the new owner submits a Large Construction Notice of Intent, SWPPP and obtains coverage. For commercial development, a SWPPP must be developed and submitted along with the LCNOI.

Residential Subdivision: The original coverage recipient is responsible for construction activities until the new owner or operator submits the Registration Form for Residential Lot Coverage and develops and implements a sediment and erosion control plan, submits a LCNOI and required documents, or applies for an individual storm water permit. Homebuilders are required to minimize off-site damage from soil erosion, sediment leaving the construction site, and poor "housekeeping" practices. Examples of individual lot sediment and erosion control plans are attached for your convenience. Sketch the controls on a copy of your site plan. Narrative notes on the site plan may also be used in addition to the erosion control symbols. In developing and implementing the plan, controls must be used from each control group (vegetative, structural, housekeeping) to prevent erosion and sediment and other pollutants from leaving the site.

4. **Housekeeping Practices.** Pollutants that may enter storm water from construction sites because of poor housekeeping may include, but are not limited to oils, grease, paints, gasoline, solvents, litter, debris, and sanitary waste.

The SWPPP should:

- designate areas for equipment maintenance and repair;
- designate areas for equipment wash off (i.e., concrete chute wash off);
- provide waste receptacles at convenient locations and provide regular collection of waste;
- provide adequately maintained sanitary facilities;
- provide protected storage areas for chemicals, paints, solvents, fertilizers, and other potentially toxic materials;
- implement spill and leak prevention practices and response procedures if spills and leaks do occur; and
- minimize the exposure of building materials, building products, construction wastes, trash and landscape materials.

5. **Post - Construction/Storm Water Management Measures.** The Storm Water Construction General Permits require that the SWPPP describe any measures that will be installed and implemented to control pollutants in storm water after construction is complete. These controls include, but are not limited to, one or more of the following:

- **Detention ponds** detain runoff in a basin for a limited time releasing it slowly, allowing sediment to drop out.

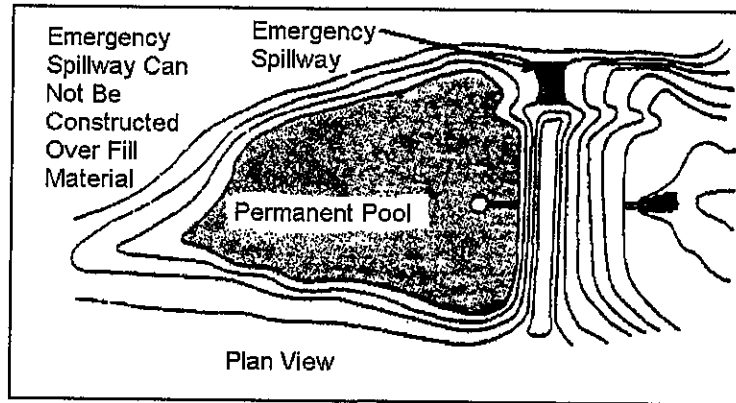

- **Retention Ponds** provides complete onsite storage and treatment of a specific volume of storm water runoff by using infiltration and evaporation. The specific volume is typically the first inch or half inch of storm water runoff containing the first flush of pollutants.

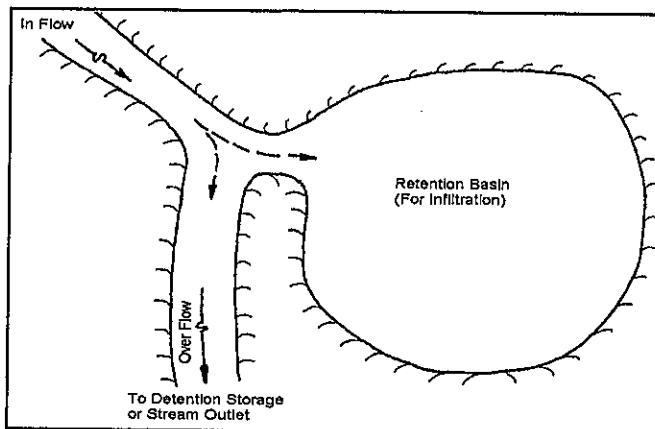

- **Constructed wetlands** are modified natural or constructed shallow basins for treatment of waters by wetland vegetation. Constructed wetlands are operated wet. They can achieve a high removal rate of sediments, BOD, organic nutrients and metals. They can also create wildlife habitat, recreation, and landscape amenities as well as corresponding higher property values.
- **Vegetated swales and natural depressions** are grass-lined, filtering sediments from the runoff and preventing erosion. Vegetated swales should have side slopes of 4:1 or flatter.
- **Velocity dissipation devices** prevent erosion from high runoff velocity, such as **riprap** placed at the discharge point.
- **Exfiltration trenches** are a feasible option where soils are permeable and the water table is well below the surface. Exfiltration trenches retain storm water for release into the soil. Storm water runoff is temporarily stored in perforated pipe or coarse aggregate and allowed to infiltrate the trench walls and, to some extent, trench bottoms. Trenches require regular maintenance to prevent clogs.

PART III

PREPARE SWPPP

1. **Write a Description of Controls.** Once you have finished selecting the vegetative and structural controls, list each control you plan to implement. There are specific controls in the construction permits that must be implemented unless infeasible.
2. **Prepare a scaled site map showing:**
 - Boundaries of property and proposed construction activities, noting any phasing of construction activities,
 - Original and proposed contours (if feasible), with steep slopes identified
 - North arrow
 - Drainage pattern arrows
 - Location of sensitive areas, such as wetlands, perennial streams and adjacent receiving water bodies, (if the receiving waterbody is not depicted on the map, the name and direction shall be listed in text form on the map)
 - Location of any storm drain inlets and any receiving MS4
 - All erosion and sediment controls (vegetative and structural)
 - Any post-construction control measures, and
 - Location of housekeeping practices

If the construction project is a linear construction project (e.g., pipeline, highway, etc.), a scaled site map is not required, however standard diagrams (e.g., cross sections showing dimensions and labeled components of erosion and sediment controls to be used must be submitted.

3. **Implementation Sequence.** Indicate the order in which activities will take place. When work is discontinued for 14 days or more in a disturbed area or completed, appropriate vegetative and structural practices must be initiated immediately. Several general implementation principles are:
 - **Install** downslope and perimeter controls before other site work. Build sediment basins before major site grading.
 - **Divert** upslope water around area before major site grading.
 - **Do not disturb** an area until it is necessary.
 - **Time** construction activities to limit impact from seasonal weather.
 - **Cover or stabilize** disturbed areas as soon as possible.
 - **Do not remove** temporary controls until after site stabilization.
4. **Inspection and Maintenance Schedules.** A description of an inspection and maintenance schedule for all disturbed areas, material storage areas, and erosion and sediment controls that were identified as part of the plan shall be included in the SWPPP. Non-functioning controls shall be repaired, replaced or supplemented with functional controls within 24 hours of discovery or as soon as field conditions allow. During permit coverage all erosion controls must be inspected at least once per week for a minimum of four (4) inspections per month and as often as necessary to ensure that appropriate erosion and sediment controls have been properly constructed and maintained and determine if additional or alternative control measures are required. The MDEQ strongly recommends that coverage recipients perform a "walk through" inspection of the construction site before anticipated storm events. Controls must be in good operating condition until the area they protect has been completely stabilized and the construction activity is complete. The SWPPP must also identify all allowable source of non-storm water discharges listed in ACT2, T-2 of the Large Construction Storm Water General Permit, except for flows from actual fire fighting activities, which are combined with storm water discharges associated with large construction activity. The inspection

information must be recorded on the forms developed and provided by the MDEQ. These forms are available on the General Permits Branch page found at:
http://www.deq.state.ms.us/MDEQ.nsf/page/epd_epdgeneral?OpenDocument

PART IV

APPLY FOR PERMIT COVERAGE

The MDEQ now has two different storm water general permits that cover construction activities in Mississippi. Construction activities that disturb one acre to less than five acres require coverage under the Small Construction General Permit. The requirements of the Small Construction General Permit are similar to the Large Construction General Permit. However, there is one fundamental difference. **The Small Construction General Permit has no submittals to the MDEQ unless specifically requested.** The owner or operator must complete the Small Construction Notice of Intent (SCNOI) and keep the form on the project site or locally available. In addition, the owner or operator must develop and implement a Storm Water Pollution Prevention Plan (SWPPP). The SWPPP must also be kept at the project site or locally available.

For projects that are considered large construction activities, the owner or operator must submit a Large Construction Notice of Intent (LCNOI) to the Office of Pollution Control (OPC) along with the SWPPP and the USGS Quad Map (or copy). The LCNOI summarizes information about you, your site, the prime contractor, and receiving water(s). The LCNOI is due at least 30 days prior to the commencement of construction. An **authorized representative**, as described in the general permit, must sign the LCNOI. If the owner signs the LCNOI and will not serve as the prime contractor, the prime contractor should sign and submit the Prime Contractors Certification form provided in the LCNOI prior to actual construction.

Operators of construction sites should keep in mind that local governments (cities, towns, counties) often have their own requirements for construction sites. Compliance with local requirements does not mean compliance with state requirements or vice versa. Forms may be found on our website at:

http://www.deq.state.ms.us/MDEQ.nsf/page/epd_epdgeneral?OpenDocument

PART V

IMPLEMENT CONTROLS

Erosion and sediment controls shall be constructed and the stabilization measures shall be applied in the order that was indicated in the implementation sequence. It is important that appropriate construction workers are aware of the SWPPP and have ready access to it. The owner or prime contractor must **inspect and maintain** controls, recording damages or deficiencies and corrective measures, and **complete monthly inspection reports** using the form provided by the MDEQ. Problems should be corrected within 24 hours or as soon as practicable after an inspection. Changes to correct deficiencies in the SWPPP should also be made as soon as practicable after the inspection. The SWPPP must accurately reflect the site and construction and be corrected if it does not.

PART VI

STABILIZE SITE & TERMINATE COVERAGE

Upon successful completion of all permanent erosion and sediment controls for a Large Construction project, the Office of Pollution Control must be notified by submission of a Request for Termination of Coverage (RFT) form. The RFT form must be fully completed by both the owner and operator and include original signatures by both parties. The RFT form is provided in the Storm Water Large Construction General Permit. If the entire RFT form is fully completed and the MDEQ on site inspection does not show any problems, a letter will be sent to the coverage recipient stating the permit has been terminated. At this point, the permittees are relieved of their responsibility. Failure to submit the RFT is a permit violation and subject to enforcement action.

SAMPLE STORM WATER POLLUTION PREVENTION PLAN (SWPPP)

Site Information

The construction of two commercial buildings and associated pavements will disturb 7.2 acres. Three-fourths of this site has a medium erosion hazard. The remainder of the site has 10 to 20 percent slopes that are highly erodible. An intermittent drain on the north end of the property drains the site to "Any-Name" Creek. "Any-Name" Creek stream is not on the 303(d) list for siltation, turbidity or habitat alterations, therefore additional controls that are warranted for a site discharging to listed receiving streams are not required.

Controls

Vegetative Controls: A 15-foot undisturbed vegetative buffer zone will be maintained around the perimeter of the site. Existing trees will be preserved where possible. All diversions will be seeded (permanent seeding) within seven calendar days of construction. Topsoil will be stockpiled for use in landscaping. Grass-lined waterways will be constructed and lined with temporary straw-net liners and will be constructed around both buildings. All 3:1 cut slopes will be roughened by disking prior to seeding. The slope on the south side of the intermittent stream will be sodded with Bermuda grass. Any disturbed areas that will be left undisturbed for 14 or more days will be seeded (temporary seeding) immediately. After final grading, all disturbed areas will be seeded (permanent seeding) immediately.

Structural Controls: A sediment basin with a surface discharge will be constructed at the end of the existing intermittent drainage to the north (drainage area: 4.8 acres). A sediment basin will be constructed at the southwest corner of the property where runoff leaves the property. Storm water will be directed to these basins with the assistance of diversions and grassed waterways. Upslope waters will be diverted around disturbed areas. A level spreader will serve as the outlet for the diversion southeast of the buildings. All cut slopes will be at or below a 3:1 grade. A construction entrance will be built and any accumulation of mud on vehicle tires will be washed, if needed, during muddy conditions. Inlet protection (silt fences) will be installed at all storm drain inlets. A silt fence will be constructed around the stockpile. The eroding natural drainage way on the north end of the site will be lined with rip rap (which is covered by a Nationwide Permit # 13 – *an individual 404 Permit is not required because the activity is less than 500 linear feet and has less than 1 cubic yard of rip rap per linear foot - no notification of Corps required.*). Riprap will be placed at all culvert outlet aprons. A sediment pit will be excavated for concrete trucks to wash the mixer chutes and a memo will be sent to the concrete supplier to use a minimum amount of water. Drivers will be instructed to return any materials to the concrete batch plant and complete final washing procedures at that location.

Housekeeping Practices. All equipment maintenance and repair will be done offsite. Trash cans will be placed at convenient locations throughout the site. The main trash collection bin will be located on the northeast corner of the site and will be picked up weekly by the city. Paints, solvents, fertilizers, or any other potentially toxic materials will not be stored onsite. Portable sanitary facilities will be provided for construction workers. There is a marked and designated area for concrete truck wash off.

Post Construction/Storm Water Management Measures: The temporary sediment basin will be converted to a detention basin after construction. Riprap will be placed at concentrated storm water discharge points to prevent erosion from high runoff velocities.

Implementation Sequence

1) build construction entrance/exit. 2) install sediment basin with needed riprap. 3) contour and riprap intermittent drainage way to the north. 4) rough grade site, construct diversions and drainage ways, stockpile topsoil and install silt fence around stockpile, install culverts with inlet/outlet protection (silt fence), level spreader and riprap. 5) plant needed temporary vegetation on disturbed areas. 6) construct buildings and parking lots. 7) finish slopes around buildings, roughen slopes and vegetate. 8) after site is stabilized, remove all temporary measures, vegetating these areas, and convert sediment basin to a detention basin.

Maintenance Plan

Check all disturbed areas, erosion and sediment controls after each significant rainfall but not less than once per week. Make needed repairs within 24 hours. Remove sediment from the basin, inlet protection devices and silt fences when accumulated sediment has reached 50 percent capacity. Replace non-functional silt fence. Maintain all vegetated areas to provide proper ground cover - reseed, fertilize, and mulch as needed.

COMMON PLAN OF DEVELOPMENT OR SALE SWPPP REQUIREMENTS FOR INDIVIDUAL LOTS IN A RESIDENTIAL SUBDIVISION

When rain falls on exposed soil it can wash away valuable topsoil. It also carries soil, nutrients and other pollutants into streets, gutters and ditches, where it then travels to lakes, rivers, streams or wetlands. Polluted runoff can cause excessive growth of aquatic weeds and algae and reduce recreational opportunities such as swimming and fishing. Sediment laden runoff can also destroy fish habitat reducing productive fishing opportunities. In addition, sediment-laden runoff can also clog pipes, ditches, streams and basins resulting in increased flooding and maintenance cost. Therefore, the homebuilder is required to minimize off-site damage from soil erosion, sediment leaving the construction site, and poor "housekeeping" practices. This requirement must be accomplished by developing and implementing a Storm Water Pollution Prevention Plan (SWPPP). Some examples of individual lot SWPPPs are attached for your convenience. Sketch the controls on a copy of your site plan. Narrative notes on the site plan may also be used in addition to the erosion control symbols.

In developing and implementing the SWPPP, controls must be used from each control group (vegetative, structural, housekeeping) to prevent erosion and sediment and other pollutants from leaving the site. Commonly used controls include:

Vegetative Controls

Temporary vegetation includes annual grasses that sprout quickly such as annual rye, browntop millet, oats, and winter wheat. These grow quickly with little care and can protect the soil from rainfall and act as a filter. They will not provide permanent cover. Permanent cover must be established as soon as possible. When a disturbed area will be left undisturbed for fourteen days or more, the appropriate temporary or permanent vegetative practices shall be implemented immediately.

Mulching is the placement of hay grass, woodchips, straw, or synthetic material on the soil to provide temporary cover to protect the soil from rain. Mulching may be the only option during the winter when seeding or sodding is not possible. Mulch must stay in place to be effective. Netting, stakes or chemical binders are used to anchor some types of mulch. Be sure to reinstall washed-out mulch and anchor if necessary until permanent cover is established.

Permanent stabilization is required as soon as possible. Silt fences, and other temporary measures must be removed following permanent stabilization. Establishing a permanent vegetative cover on disturbed areas using either sod, perennial seed, trees or shrubs is required. When a disturbed area will be left undisturbed for thirty days or more, the appropriate temporary or permanent vegetative practices shall be implemented within seven calendar days.

Vegetative buffer zones are undisturbed or planted vegetated areas that are between construction activities and water bodies, street, drainage ditch, etc. A 15-foot wide buffer is recommended.

Structural Controls

Silt fences are temporary sediment barriers made of filter fabric buried at the bottom, stretched, and supported by stakes. The silt fence slows runoff and allows it to puddle or pond, so soil and sediment can settle out before leaving the site. The bottom eight to twelve (8-12) inches of fence must either be sliced in or buried in a trench about four to six (4-6) inches deep by four to six inches wide. **Silt fences that are not buried are improperly installed. They have no useful function, are a waste of money, and may result in enforcement action.** Stakes must be on the downstream side of the fence and spaced about three (3) feet apart. Silt fence must not be installed across streams, ditches, waterways, or other concentrated flow areas. Place fences on the contour or perpendicular to the slope of the hill so that water and sediment will pond behind the fence. **Turn ends uphill** to prevent water going around the end. Install on the downslope, downhill, downstream, or low side of your lot. Keep the fence/barrier in place until grass is established.

Construction entrance/exits are stone stabilized site entrances which reduce sediment tracked onto public roads. Apply gravel or crushed rock to the driveway area and restrict traffic to this one route. Use 3 to 6 inch gravel over a geotextile fabric. At the end of each day sweep or scrape up any soil tracked onto the street. Limit "standard" vehicle access (including workers' vehicles) to only streets and roads, keep vehicles off of future yard areas; limit tracking of mud onto streets by requiring any required vehicles to use designated access drives. Streets are conduits for storm water, it is important to keep mud and sediment off the streets.

Stockpiles of sand or soil should be covered with plastic or tarps at the end of each workday, or surrounded with silt fence or haybales. Do not locate a stockpile near a street, storm drain inlet, or ditch.

Slope drains are piping or lined channels that carry storm water downslope without erosion. A good example would be a downspout extender. Extenders may be used to protect temporarily stabilized areas from roof runoff. Extenders can direct water from roof gutters to paved or grassed areas. Remove extenders following permanent stabilization.

Erosion control blankets or mats are machine-produced mats of straw or other fibers held together with netting that provide temporary or permanent stabilization in critical areas, such as slopes or channels, so that vegetation may be established.

Additional Controls: The above controls are the more common practices used at small construction sites. There are a number of other controls, techniques and manufactured product available. A few examples include hydro seeding, inlet protection devices, diversion berms, silt dikes and fiber logs. Even something as simple as a tarp or plastic may provide temporary cover for small exposed areas. You may wish to contact an erosion and sediment control specialist, local building official, or MDEQ for further information. In addition, MDEQ has several guidance manuals that may be of assistance and the internet has abundant guidance on construction BMPs.

Housekeeping Controls

Pollutants that may enter storm water from construction sites because of poor housekeeping include oils, grease, paints, gasoline, solvents, litter, debris, and sanitary waste. Good housekeeping practices include:

- Minimize the exposure of building materials, building products, construction wastes, trash and landscape materials
- Frequent cleaning of trash and debris, providing waste receptacles at convenient locations and providing regular collection of waste;
- Directing concrete trucks to the subdivision's designated wash-off area(s) or back to the Ready-Mix facility;
- Providing protected storage areas for chemicals, paints, solvents, fertilizers, and other potentially toxic materials; and
- Providing adequately maintained sanitary facilities.

In addition, you should be aware that State air regulations prohibit the open burning of residential solid waste.

EXAMPLE INDIVIDUAL LOT SITE MAPS

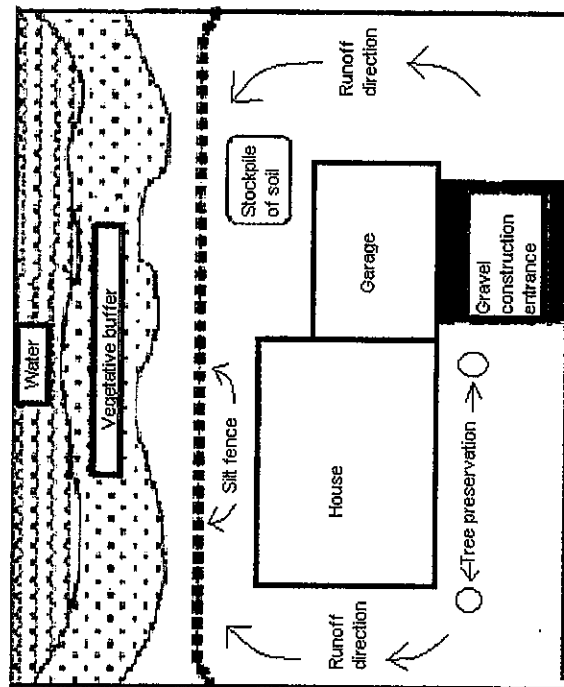
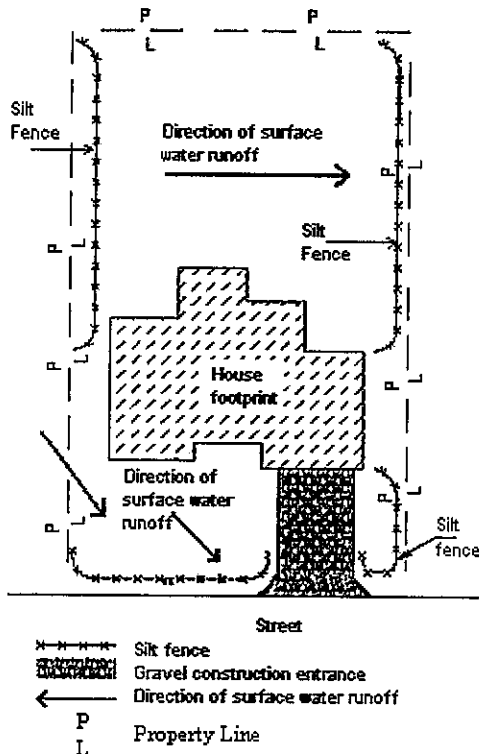
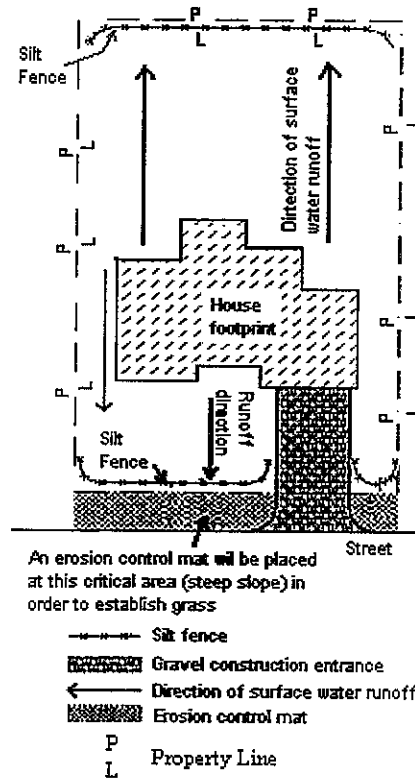
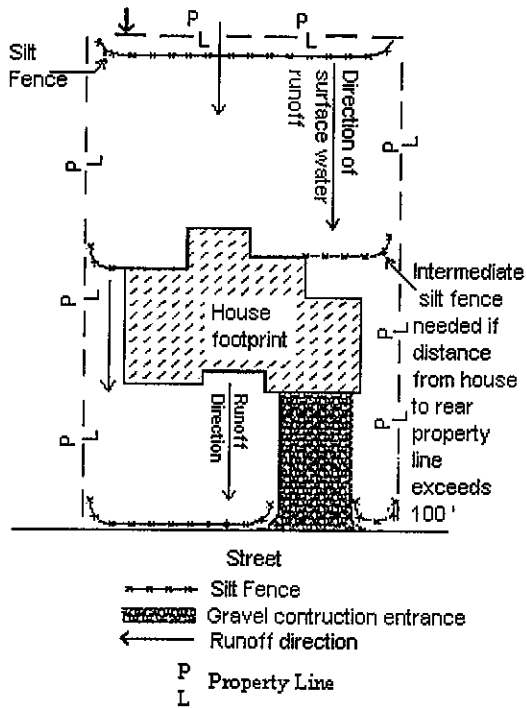

All disturbed areas will be temporarily seeded with ryegrass. After final grade has been reached, all disturbed areas will be sodded with bermuda grass.

Worksheet 1 - Checklist Sheet for Erosion and Sediment Controls

To aid in choosing all needed controls, check off practices to be used. Describe in

SWPPP and show locations on site map.

STRUCTURAL PRACTICES

- | | |
|---|---|
| <input type="checkbox"/> Check Dam | <input type="checkbox"/> Construction Entrance/Exit |
| <input type="checkbox"/> Diversion | <input type="checkbox"/> Storm Drain Inlet Protection |
| <input type="checkbox"/> Level Spreader | <input type="checkbox"/> Lined Waterway |
| <input type="checkbox"/> Slope Drains | <input type="checkbox"/> Rip-Rap Outlet Protection |
| <input type="checkbox"/> Sediment Basin | <input type="checkbox"/> Silt Fence |
| <input type="checkbox"/> Slope Breaks | <input type="checkbox"/> Straw Bale Barrier |
| <input type="checkbox"/> Other Controls _____ | |

VEGETATIVE PRACTICES

- | | |
|---|--|
| <input type="checkbox"/> Mulching | <input type="checkbox"/> Permanent Seeding |
| <input type="checkbox"/> Protection of Trees | <input type="checkbox"/> Surface Roughening |
| <input type="checkbox"/> Sod Stabilization | <input type="checkbox"/> Temporary Seeding |
| <input type="checkbox"/> Tree Preservation | <input type="checkbox"/> Tillage, with Lime and Fertilizer |
| <input type="checkbox"/> Vegetative Buffer Strips | |
| <input type="checkbox"/> Other Controls _____ | |

CONTROLS FOR INDIVIDUAL LOTS IN SUBDIVISIONS

- | | |
|--|--|
| <input type="checkbox"/> Subdivision Covenants | <input type="checkbox"/> Lot Purchase Contract |
| <input type="checkbox"/> Local Ordinance | <input type="checkbox"/> Architectural Review Requirements |
| <input type="checkbox"/> Other Controls _____ | |

HOUSEKEEPING PRACTICES

- Areas for maintenance and repair
- Storage for toxic materials
- Concrete Washout Areas
- Other Controls _____
- Waste receptacles
- Sanitary facilities

POST CONSTRUCTION CONTROL MEASURES

- Detention Basin
- Wetlands
- Vegetated Swales and Natural Depressions
- Other Controls _____
- Retention Pond
- Velocity Dissipation Devices

FREQUENTLY ASKED QUESTIONS

- Q. Are there any fees associated with CNOI applications or permit coverage?**
- A. No. The MDEQ general permits do not require a fee at this time.
- Q. What should I do if my general permit coverage expires and my project has not been completed?**
- A. If the permit is reissued or replaced with a new one before the current one expires, you will need to comply with whatever conditions the new permit requires in order to transition coverage from the old permit. This usually includes submitting a re-coverage form that will be sent to you along with a letter of instruction and a copy of the reissued general permit. The MDEQ will contact you when a new is permit issued. You do not need to do anything until you are contacted.
- Q. What is a SWPPP?**
- A. This acronym stands for Storm Water Pollution Prevention Plan. For construction activities, it is a plan which describes appropriate practices which will reduce erosion and mitigate sediment from leaving the construction site - an erosion and sediment control plan. See page 16 for instructions on preparing a SWPPP.
- Q. Where can I get assistance?**
- A. If you do not have the expertise - hire an engineer or consultant who has knowledge of erosion and sediment control. Private land owners may go to the Natural Resource Conservation Service (NRCS).
- Q. How do I terminate a project?**
- A.1. Within 30 days of final stabilization for a covered project, a completed Request for Termination (RFT) of Coverage form (provided in the Large Construction Forms Package) shall be submitted to the Permit Board. The MDEQ staff will inspect the site, and if no erosion or sediment control problems are identified and adequate permanent controls are established, the owner or operator will receive a letter of termination from the MDEQ.
- A.2. The coverage recipient of a “larger common plan of development or sale” must submit a RFT within 30 days after the following conditions are met:
- (1) Final stabilization has been achieved on all portions of the site for which the coverage recipient is responsible, and
 - (2) Other owners or operators have assumed control over all areas of the site that have not achieved final stabilization.
- A.3. The coverage recipient of a residential “larger common plan of development or sale” must submit a copy of the MDEQ Registration Form for each lot sold with the RFT.
- A.4. Residential lot owners or operators that have completed the MDEQ Registration Form are not required to submit a RFT, unless specifically requested by the MDEQ staff. The lot permit coverage is considered terminated upon successful completion of all permanent erosion and sediment controls.

Q. What is the threshold of land disturbance that will require me to obtain storm water permit coverage?

A.1. Projects that are considered to be Large Construction are: land disturbing activities of five (5) acres or greater; or for land disturbing activities that are part of a larger common plan of development or sale that will disturb five (5) or more acres.

A.2. Projects that are considered to be Small Construction are: land disturbing activities of one (1) acre to less than five (5) acres; or for land disturbing activities less than one (1) acre that are part of a larger common plan of development or sale that will disturb one (1) to less than five (5) acres.

Q. What is meant by a “larger common plan of development or sale?”

A. A “larger common plan of development or sale” means a contiguous area where multiple separate and distinct construction activities are occurring under one plan. The plan in a common plan of development or sale is broadly defined as any announcement or piece of documentation (including a sign, public notice or hearing, sales pitch, advertisement, drawing, permit application, zoning request, computer design, etc.) or physical demarcation (including boundary signs, lot stakes, surveyor markings, etc.) indicating that construction activities may occur on a specific plot.

Q. For projects such as a 100-mile pipeline project, what location should be provided on the CNOI?

A. The beginning of a linear construction project should be used as the location and all counties that the project traverses should be listed on the MDED’s CNOI Form.

Q. Is clearing of lands specifically for agricultural purposes regulated construction activity (40 CFR 122.26(b)(14)(x)) under the storm water program?

A. No. Although the clearing of land may be greater than five acres, any amount of clearing for agricultural purposes is not considered an industrial activity under the storm water regulations. Section 402(l)(1) of the 1987 Water Quality Act exempts agricultural storm water discharges from NPDES permitting requirements including storm water permitting. This exemption only applies, however, if the clearing of land is solely for agricultural purposes. For example, the clearing of land for the purpose of building a retail store would be the beginning of construction activity and require permitting.

Q. If a construction activity that disturbs less than one acre occurs at a regulated industrial activity currently covered by the State’s industrial storm water permit, does the regulated industry have to modify its pollution prevention plan to include controls for the area of construction?

A. Yes. Regulated industrial activities covered by Mississippi’s storm water industrial general permits must revise their pollution prevention plan to address all new sources of pollution and runoff including those from construction activities disturbing less than one acre, that occurred on the site of the regulated industry. If the disturbance is one (1) acres or greater then the facility should submit an NOI for coverage under the State’s construction storm water general permit.

Q. For a construction activity that uses off site “borrow pits” for excavation of fill material or sand and gravel, should the number of disturbed acres at the borrow pit be added to the number of acres at the construction site to determine the total number of disturbed acres?

A. No, off site borrow pits are not considered part of the on site construction activity. If a borrow pit is specifically used for the removal of materials such as sand, gravel, and clay, the pit is considered

a mine and is classified under SIC code 14. Such sites would be regulated as industrial activity as defined at 40 CFR 122.26(b)(14)(iii).

Q. Who must apply for permit coverage for construction activities?

A. Under the Mississippi storm water program, the owner or operator of a regulated activity or discharge must apply for storm water permit coverage. The operator of a construction activity is the party or parties that either individually or taken together meet the following two criteria: (1) they have operational control over the site specifications (including the ability to make modifications in specifications); or (2) they have the day-to-day operational control of those activities at the site necessary to ensure compliance with plan requirements and permit conditions. Usually the owner of the project initially files the CNOI and the contractor would complete and submit the "prime contractor form" when selected.

Q. Who is responsible for permit compliance?

A. The owner and the operator have joint and severable liability for permit compliance.

Q. Does construction activity encompass repaving of roads?

A. Repaving is not regulated under the large construction storm water general permit unless five or more acres of underlying and/or surrounding soil is cleared, graded or excavated as part of the repaving operation.

Q. Does construction activity encompass routine road maintenance?

A. No. Construction activity does not include routine maintenance that is performed to maintain the original line and grade, hydraulic capacity, or original purpose of the site.

Q. Would building demolition constitute a land disturbing activity and require a storm water construction permit application?

A. The definition of land disturbing activity includes but is not limited to clearing, grading and excavation. At a demolition site, disturbed areas might include where building materials, demolition equipment, or disturbed soil are situated, which may alter the surface of the land. Therefore, demolition activities that disturb five or more acres of land would be subject to storm water construction permit application requirements.

Q. Do storm water construction general permits authorize non-storm water discharges?

A. The following non-storm water discharges are authorized: discharges from fire-fighting activities, fire hydrant flushing, water used to control dust, potable water including uncontaminated water line flushing, routine external building wash down that does not use detergents, pavement wash waters where spills or leaks of toxic or hazardous materials have not occurred (unless all spilled material has been removed) and where detergents are not used, uncontaminated air conditioning or compressor condensate, uncontaminated ground water or spring water, foundation or footing drains where flows are not contaminated with process materials such as solvents, uncontaminated excavation dewatering, landscape irrigation, water used to wash vehicles, wheel wash water and other wash waters where detergents are not use. However, they must be included in the SWPPP and addressed by the appropriate BMP.

APPENDIX E: Drainage Areas & Sedimentation Basin Storage Calculations

Existing - Drainage Areas & Sedimentation Basin Storage

Drainage Area	Corresponding Sediment Basin	Total Drainage Area (ft ²)	Total Drainage Area (ac)	Required Sediment Storage Volume (ft ³)	Sediment Storage Volume Provided (ft ³)
DA-1	SB-1	414741	9.52	34276.12	36000.00
DA-3	-	174240	4.00	Not Required	
DA-4	SB-4	266105	6.11	21992.15	26807.50
DA-5	-	349800	8.03	Not Required	
DA-P1	No Discharge Pond	2301401	52.83	190198.43	2166140.00

Sediment Basin	Length (ft)	Width (ft)	Avg. Depth (ft)	Area (ft ²)	Volume (ft ³)	Required Volume (ft ³)
SB-1	200	60	3	12000	36000.00	34276.12
SB-4	320	40	2	12800	25600.00	21992.15
No Discharge Pond	-	-	4*	541535	2166140.00	190198.43

* The No Discharge Pond maintains 2' of freeboard & has an average depth of 6' for an effective depth of 4'.

Proposed - Drainage Areas & Sedimentation Basin Storage

Drainage Area	Corresponding Sediment Basin	Total Drainage Area (ft ²)	Total Drainage Area (ac)	Required Sediment Storage Volume (ft ³)	Sediment Storage Volume Provided (ft ³)
DA-1	SB-1	385358	8.85	31847.77	36000.00
DA-3	-	174240	4.00	Not Required	
DA-4	SB-4	192094	4.41	15875.54	26807.50
DA-5	-	229026	5.26	Not Required	
DA-P1	No Discharge Pond	732355	16.81	60525.21	2166140.00
DA-P2	No Discharge Pond	609059	13.98	50335.45	2166140.00
DA-OP	Overflow Pond	1245838	28.60	102961.82	340422.00

Sediment Basin	Length (ft)	Width (ft)	Avg. Depth (ft)	Area (ft ²)	Volume (ft ³)	Required Volume (ft ³)
SB-1	200	60	3	12000.00	36000.00	31847.77
SB-4	320	40	2	12800.00	25600.00	15875.54
No Discharge Pond	-	-	4*	541535.00	2166140.00	110860.66
Overflow Pond	-	-	6**	56737.00	340422.00	102961.82

* The No Discharge Pond maintains 2' of freeboard & has an average depth of 6' for an effective depth of 4'.

** The Overflow Pond maintains 2' of freeboard & has an average depth of 8' for an effective depth of 6'.

APPENDIX F: Construction Plans

CONSTRUCTION PLANS
 for
SOUTHEASTERN TIMBER PRODUCTS, LLC
ACKERMAN, MISSISSIPPI
SANITARY / WASTEWATER SYSTEM IMPROVEMENT

240 PCA ROAD
 ACKERMAN, MISSISSIPPI
 PREPARED FOR:
 SOUTHEASTERN TIMBER PRODUCTS, LLC
 AUGUST 2023

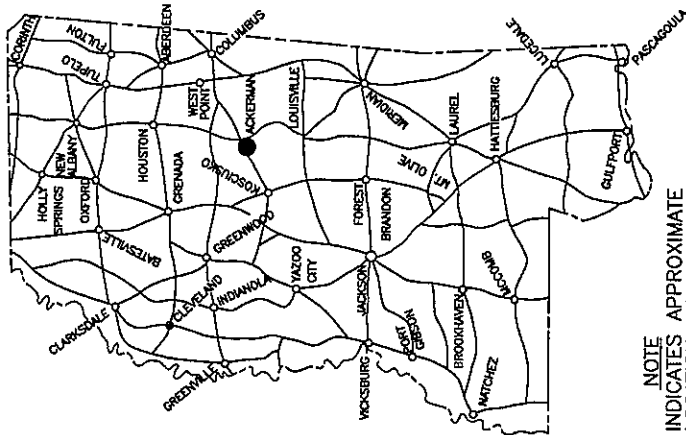

● NOTE
 INDICATES APPROXIMATE
 LOCATION OF PROJECT.

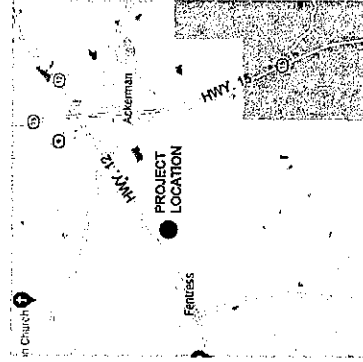

PREPARED BY:

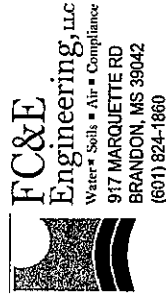

SHEET INDEX	
SHEET NO.	TITLE
Cover	Cover Sheet
C1.0	Notes
C1.1	Existing Conditions
C1.1.1	Overall Plan
C1.1.2	Erosion Control
C1.2	Hydraulic Layout
C1.3	Absorption Bed Details
C1.3.1	Absorption Bed Details
C1.4	Flumes, Manholes, & Trench Details
C1.5	Distribution Box Details
C1.5	Septic Tank Details



PROJECT # 2302
 DATE 09/07/2003
 DRAWN BY JMG
 CHECKED BY M.F.
 SCALE 1" = 30'

NO.	DATE	DESCRIPTION

CONSTRUCTION PLANS FOR
 SOUTHEASTERN TIMBER PRODUCTS, LLC
 ACKERMAN, MISSISSIPPI
 SANITARY / WASTEWATER SYSTEM
 IMPROVEMENT



C1.1

EXISTING
 CONDITIONS

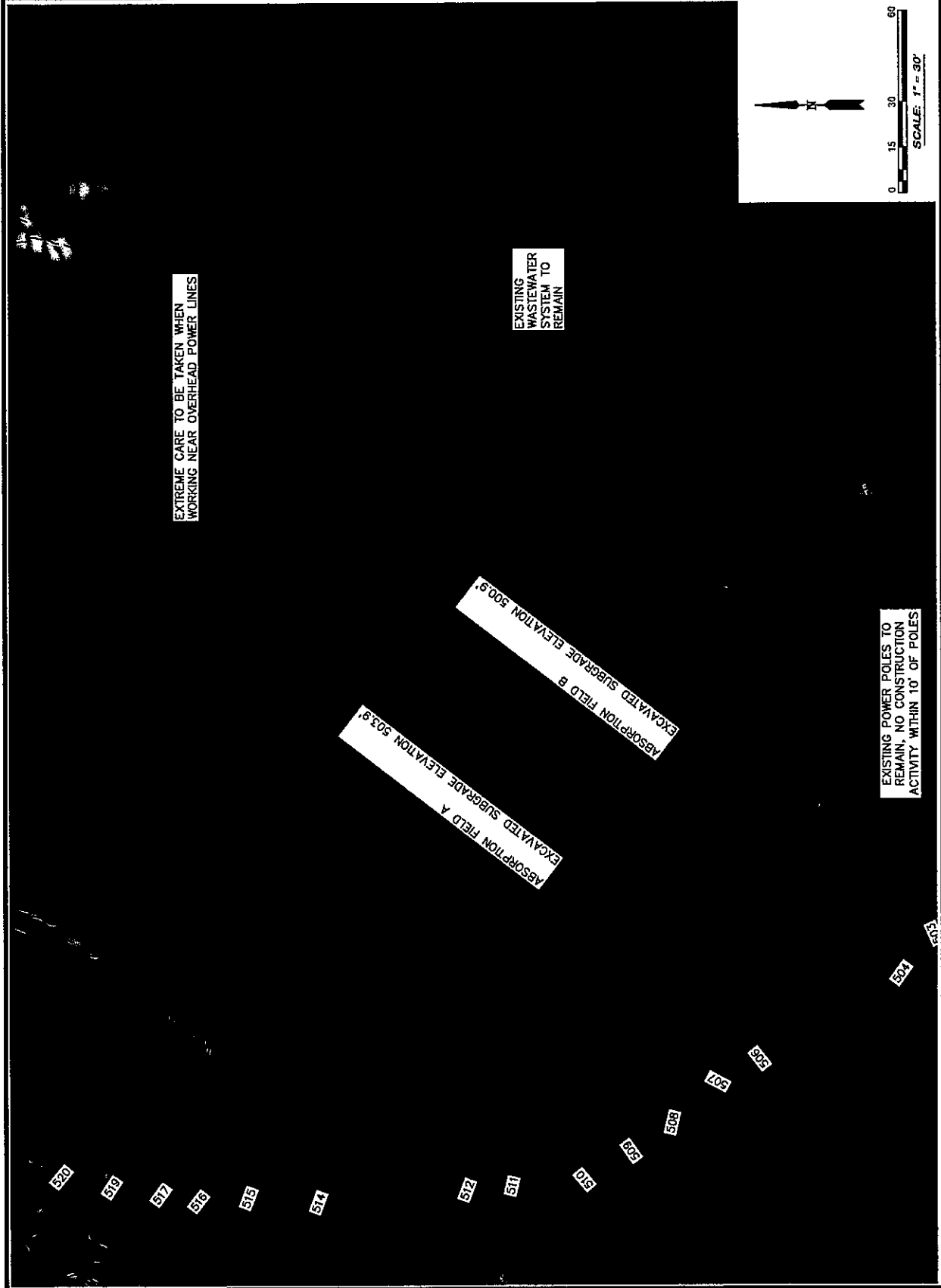

FC&E
 Engineering, Inc.
 1000 Highway 101
 Mandeville, LA 70471
 (504) 835-1800

PROJECT # 2090
 DATE 04/07/2023
 DRAWN BY ZM
 CHECKED BY JLF
 SCALE 1" = 30'

NO.	DATE	REVISION

CONSTRUCTION PLANS FOR
 SOUTHEASTERN TIMBER PRODUCTS, LLC
 ACKERMAN, MISSISSIPPI
 SANITARY / WASTEWATER SYSTEM
 IMPROVEMENT



C1.11

OVERALL PLAN

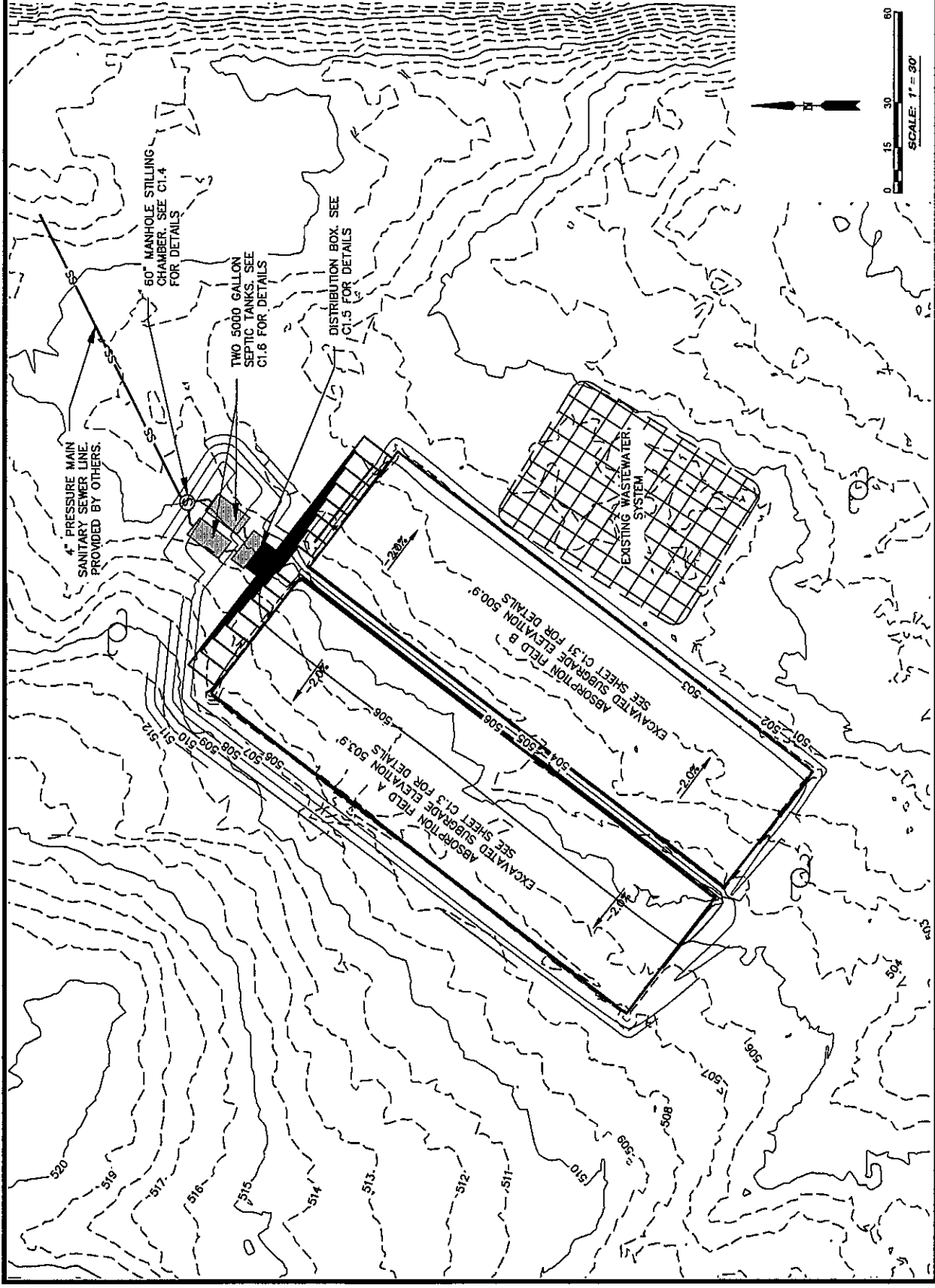



PROJECT # 2340
DATE 08/07/2003
DRAWN BY JAW
CHECKED BY JAW
SCALE 1" = 40'

NO.	DESCRIPTION	DATE	BY

CONSTRUCTION PLANS FOR
SOUTHEASTERN TIMBER PRODUCTS, LLC
ACKERMAN, MISSISSIPPI
SANITARY / WASTEWATER SYSTEM
IMPROVEMENT



C1.12
EROSION
CONTROL
PLAN

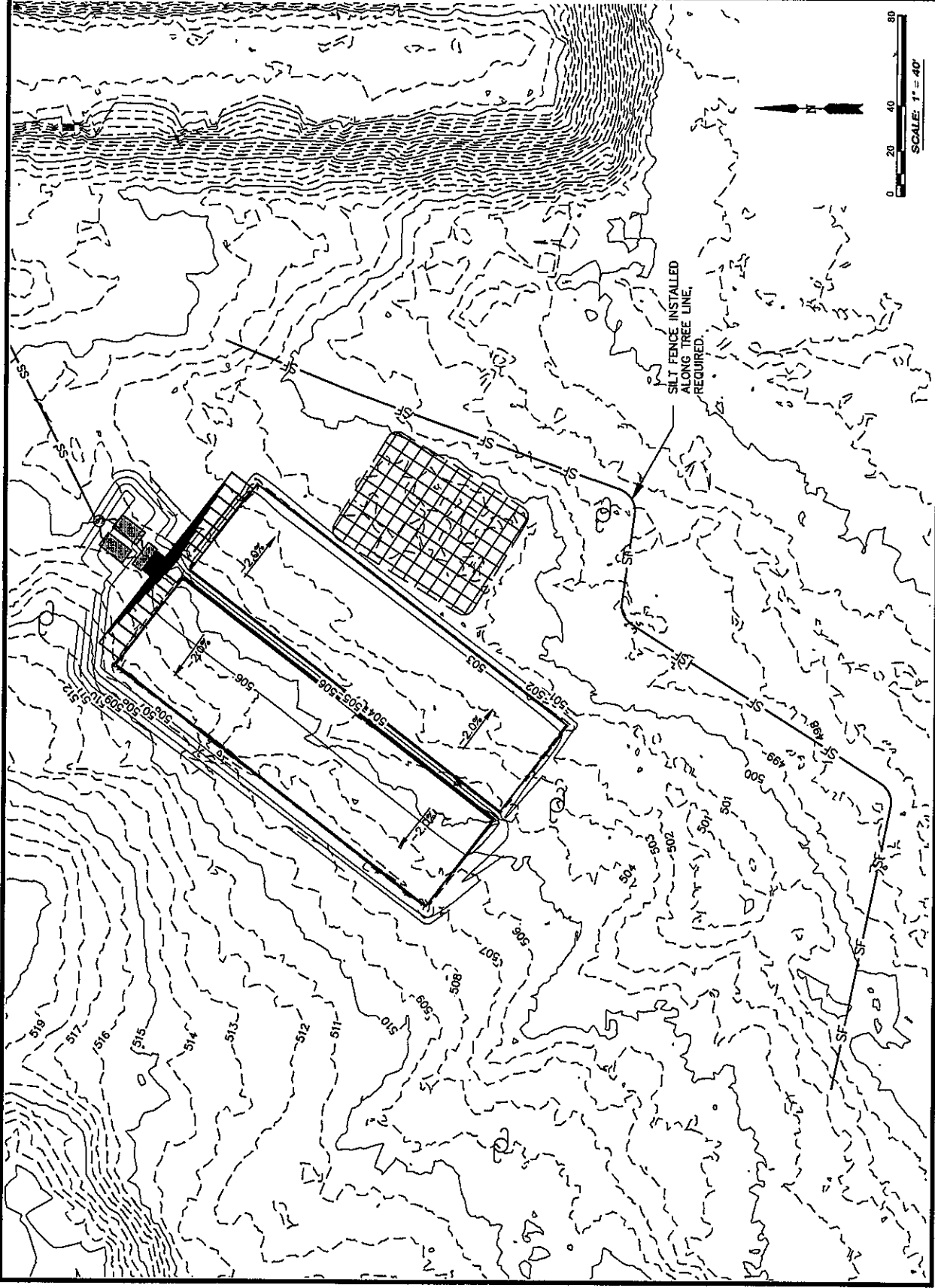



PROJECT #	2010
DATE	02/28/2013
DRAWN BY	JAM
CHECKED BY	MLT
SCALE	N.T.S.

REVISION	NO.	DATE	DESCRIPTION

CONSTRUCTION PLANS FOR
 SOUTHEASTERN TIMBER PRODUCTS, LLC
 ACKERMAN, MISSISSIPPI
 SANITARY / WASTEWATER SYSTEM IMPROVEMENT



C1.2

HYDRAULIC LAYOUT

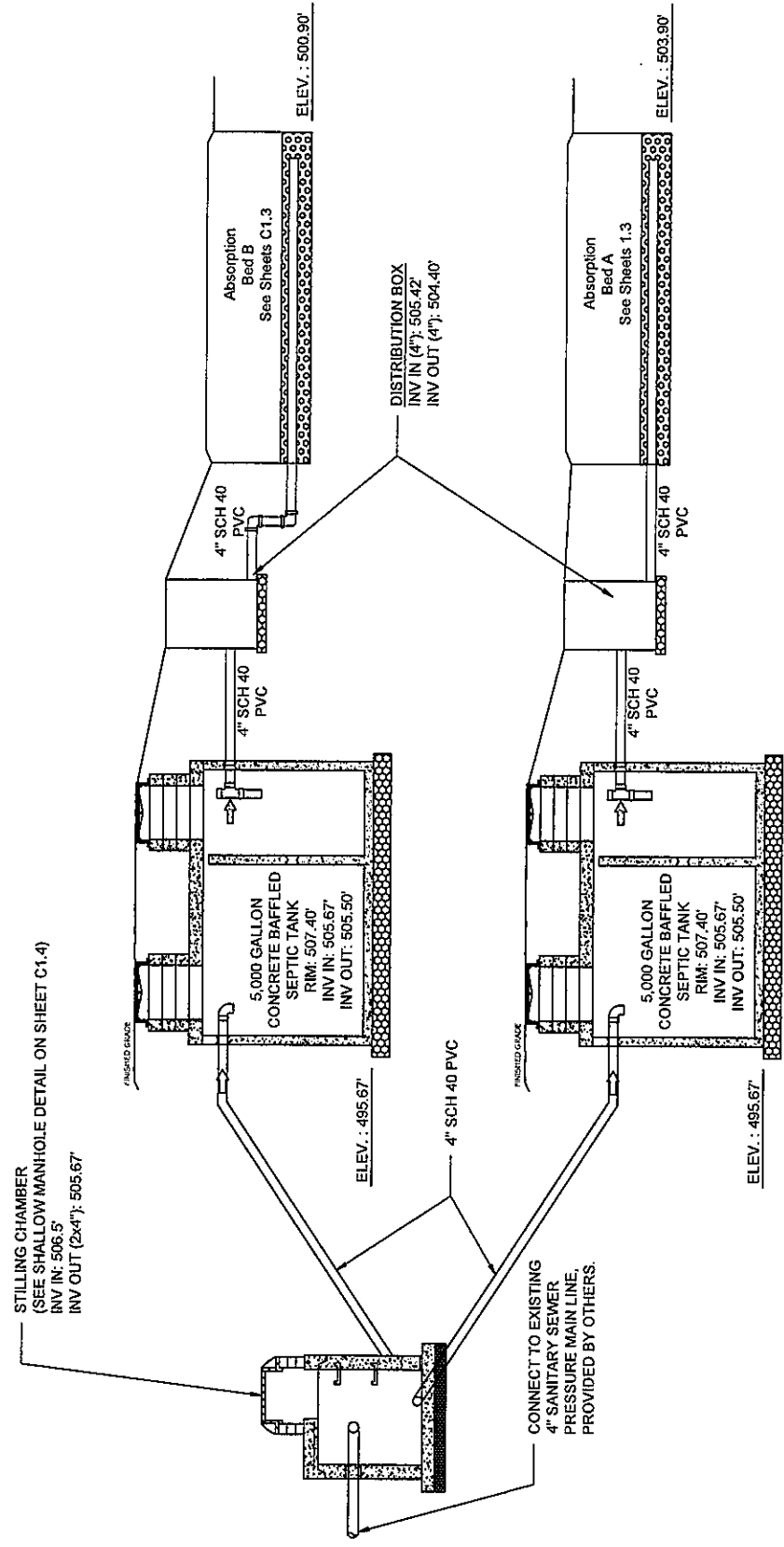

SANITARY SYSTEM HYDRAULIC LAYOUT
 NOT TO SCALE

PROJECT #	2300
DATE	06/29/2005
DRAWN BY	ZMF
CHECKED BY	NLF
SCALE	N.T.S.

NO.	DATE	DESCRIPTION

**CONSTRUCTION PLANS FOR
SOUTHEASTERN TIMBER PRODUCTS, LLC
ACKERMAN, MISSISSIPPI
SANITARY / WASTEWATER SYSTEM IMPROVEMENT**



C1.31

**ABSORPTION BED
DETAILS**

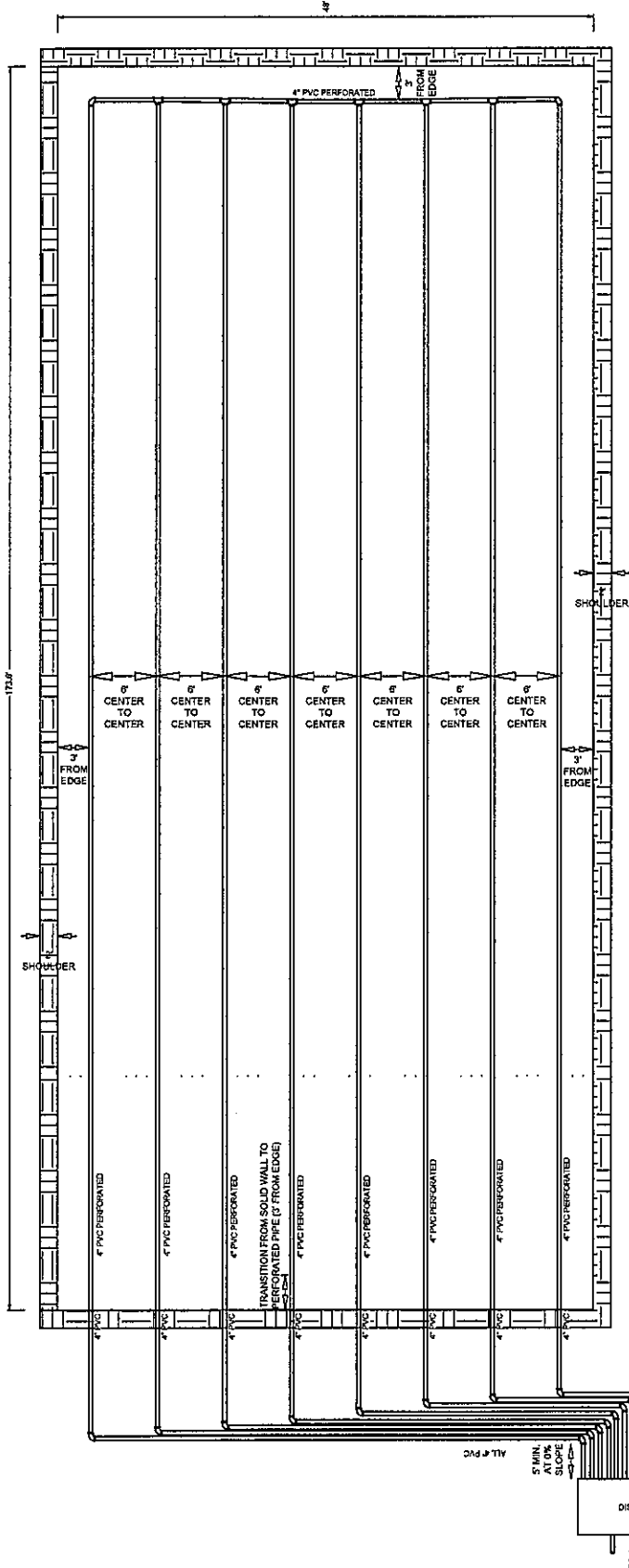

ABSORPTION FIELD B PLAN VIEW
NOT TO SCALE

NOTE: ALL PVC LINES CONNECTIONS FROM DISTRIBUTION BOX TO BE INSTALLED AND PRESURE COMPLETED LEVEL DISTRIBUTION BOX, REQUIRED.

- NOTES:**
- 1) The absorption field shall be 48" wide by 173.6' long and 2' deep at its shallowest depth. Six (6) inches of clean wash gravel (0.5" to 2.5" range) shall be placed in the bottom of the excavated field. The piping network constructed of 4" diameter Schedule 40 PVC perforated pipe shall be placed on the top of the initial six inches of gravel. An additional six (6) inches of clean wash gravel (0.5" to 2.5" range) shall be placed on top of the lower level of gravel so that at least two (2) inches of gravel is above the top of the perforated pipe. A layer of non-woven Geotextile filter cloth shall cover the entire gravelled area. Filter cloth to be approved by submittal to the Engineer. The remaining depth (of least 1") shall be covered with excavated material from the bed area and lightly compacted to original compaction levels. Topsoil shall be placed over the absorption beds and seeded with grass. Ensure that the entire absorption bed area is slightly mounded to allow for settling and a maximum of 2% slope is achieved for positive drainage of storm water away from the other Absorption bed.
 - 2) Distribution lines shall be spaced 6 feet center to center. Distribution lines shall be located 3 feet from each side walls.
 - 3) The bottom of the bed shall have a grade from level to no greater than two inches of fall over 173.6 feet. Bottom of bed shall be at elevations as indicated on Absorption Bed Detail Sheets.
 - 4) Invert of all pipes coming from the distribution box and pipes in the absorption bed shall be at elevations as indicated on Sheet C1.2.
 - 5) Bed shall not be excavated when the soil is wet enough to smear or compact easily.
 - 6) Contractor shall use care when excavating bed to prevent equipment from compacting native soil within the bed area.
 - 7) Contractor shall use light equipment during backfilling to prevent damage to bed. Equipment on the bed area shall be kept to a minimum.
 - 8) Adjacent area will require grading to direct surface water flow away from absorption bed. See Sheet C1.11.
 - 9) Absorption Bed Edge shall be placed at least 10' from tree line.

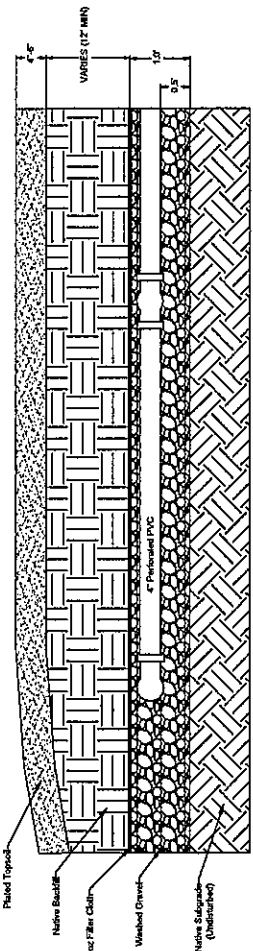

ABSORPTION BED CROSS SECTION
NOT TO SCALE

PROJECT #	5200
DATE	08/28/2003
DRAWN BY	ZJM
CHECKED BY	WJ
SCALE	N.T.S.
DESCRIPTION	
DATE	
REV	

**CONSTRUCTION PLANS FOR
 SOUTHEASTERN TIMBER PRODUCTS,
 ACKERMAN, MISSISSIPPI
 SANITARY / WASTEWATER SYSTEM IMPROVEMENT**



C1.4

**FLUME, MANHOLE,
 & TRENCH
 DETAILS**

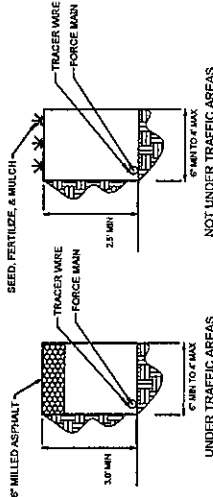

NOTES:
 1) CONCRETE THRUST BLOCKS SHALL BE INSTALLED FOR FORCE MAINS AT THE TEES.
 2) TRENCH SHALL BE FILLED WITH EXCAVATED MATERIAL AND LIGHTLY COMPACTED TO NATURAL COMPACTION LEVELS. ENSURE THAT THE ENTIRE AREA IS SLIGHTLY MONROD TO ALLOW FOR SETTLING.
 3) FINISH AND INSTALL A COATED, SOLID COPPER TRACER WIRE ON ALL SEWER LINES UNLESS IN CASING. COLOR CODE SHALL BE GREEN FOR ALL SEWER LINES. THE TRENCH ALONGSIDE THE PIPE. WIRE COLOR WILL BE GREEN FOR ALL SEWER LINES. WIRE SHOULD BE CONTINUOUS AND DAYLIGHT ABOVEGROUND.

FORCE MAIN TRENCH DETAIL

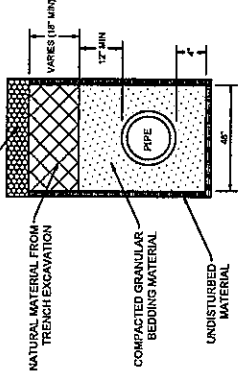

PIPE BEDDING DETAIL WHEN UNDER TRAFFIC AREAS

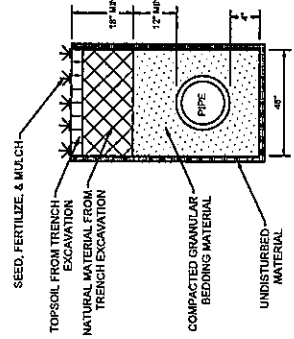

PIPE BEDDING DETAIL WHEN NOT UNDER STREET OR STRUCTURE

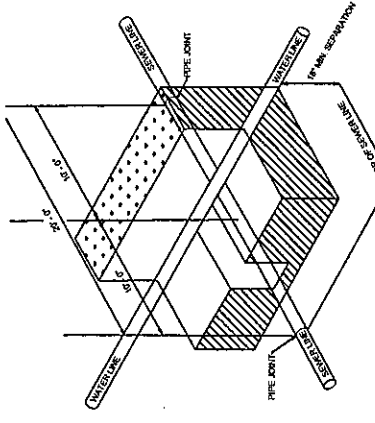

NOTES:
 1. IT IS ESSENTIAL TO MAINTAIN ADEQUATE CLEARANCE BETWEEN WATER SUPPLY AND WASTEWATER LINES. A MINIMUM SEPARATION OF TEN (10) FEET HORIZONTALLY AND/OR EIGHTEN (18) INCHES VERTICALLY BELOW SHALL BE MAINTAINED.
 2. THE SEWER LINES SHALL BE INSTALLED AS DIRECTED BY THE ENGINEER. SHALL BE TAKEN BY THE CONTRACTOR TO PREVENT CONTAMINATION OF WATERWORKS FACILITIES. THE WATER LINE SHALL ALWAYS BE AT A HIGHER ELEVATION THAN THE SEWER LINE.

WASTEWATER AND POTABLE WATER SEPARATION DETAIL

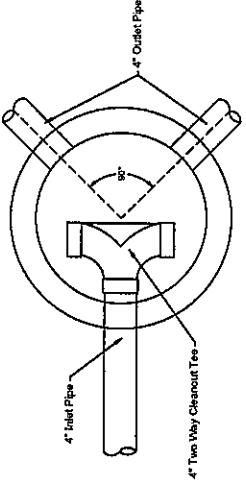

2" TEE DETAIL - PLAN VIEW

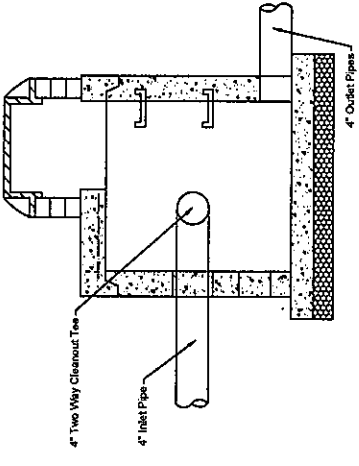

4" TEE DETAIL - ELEVATION VIEW

THRUST BLOCKING DIMENSIONS

CL. OF PIPE	TEETH	a	b	c	d	e	f	g	h	i	BEAD BENTS	w
24" F	12	1.5	1.5	1.5	1.5	1.5	1.5	1.5	1.5	1.5	1.5	1.5
18" F	9	1.5	1.5	1.5	1.5	1.5	1.5	1.5	1.5	1.5	1.5	1.5
12" F	6	1.5	1.5	1.5	1.5	1.5	1.5	1.5	1.5	1.5	1.5	1.5
6" F	3	1.5	1.5	1.5	1.5	1.5	1.5	1.5	1.5	1.5	1.5	1.5
4" F	2	1.5	1.5	1.5	1.5	1.5	1.5	1.5	1.5	1.5	1.5	1.5

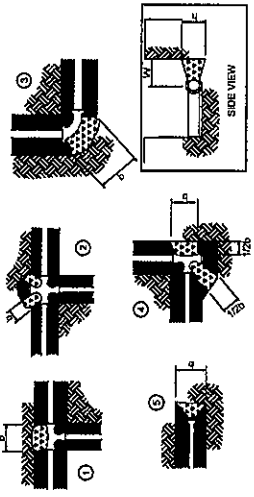

NOTE:
 THRUST BLOCKING DIMENSIONS BASED ON SOIL BEARING PRESSURE OF 1,500 PSF. SAFETY FACTOR OF 2.0. DIMENSIONS VARY IN THE FIELD ENGINEER SHALL MODIFY DIMENSIONS BASED ON SPECIFIC SOIL CONDITIONS.

① TEE
 ② CROSS USED AS TEE
 ③ 90 DEG BEND, 45 DEG BEND, 22 1/2 DEG BEND
 ④ TEE USED AS ELBOW
 ⑤ HEAD END

THRUST BLOCK DETAIL

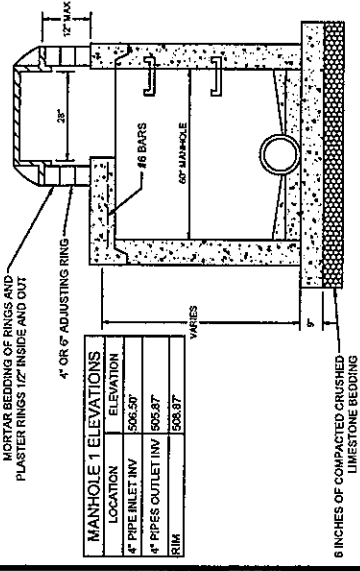

SHALLOW PRECAST CONCRETE MANHOLE (STILLING CHAMBER)

NOTES:
 1) INSTALL FLEXIBLE PIPE CONNECTIONS AT ALL PIPE OPENINGS
 2) GROUT CAVITY AROUND PIPES TO 1/2 PIPE SECTION AND TO VALVE. UNIFORM SMOOTH OR BRUSHED FINISH
 3) INTERIOR OF MANHOLE SHALL BE COATED WITH A FULL GRAIN VULCANIZING RUBBER SYSTEM.
 4) INSTALL TEE AT 4" PRESSURE MAIN OUTLET TO REDUCE INCOMING WATER ENERGY.

MANHOLE 1 ELEVATIONS

LOCATION	ELEVATION
4" PIPE INLET INV	506.57
4" PIPE OUTLET INV	505.97
RIM	505.37

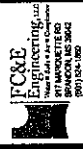

PROJECT #	2200
DATE	08/01/2023
DESIGN BY	ZML
CHECKED BY	ML
SCALE	AS SHOWN

REVISION	NO.	DESCRIPTION

CONSTRUCTION PLANS FOR
SOUTHEASTERN TIMBER PRODUCTS, LLC
ACKERMAN, MISSISSIPPI
SANITARY / WASTEWATER SYSTEM IMPROVEMENT



C1.5

DISTRIBUTION BOX
DETAILS

DISTRIBUTION BOX DETAILS

NOTES:

- 1) All walls are 4 inch concrete.
- 2) Inlet hole diameter shall accommodate a 4 inch schedule 40 pvc pipe.
- 3) Holes in baffle wall shall be 4 inch diameter.
- 4) Discharge outlet diameter shall accommodate a 4 inch pvc pipe.
- 5) Distribution box shall be placed level within 0.1 inches on top of 6 inches of compacted crushed limestone bedding.
- 6) 24 inch diameter risers shall extend 6 inches from top of distribution box. Each riser shall have a water tight removable lid.
- 7) Water balance test to be conducted with Engineer present to confirm flow from inlets evenly balanced between all outlets, Required.

PLAN VIEW

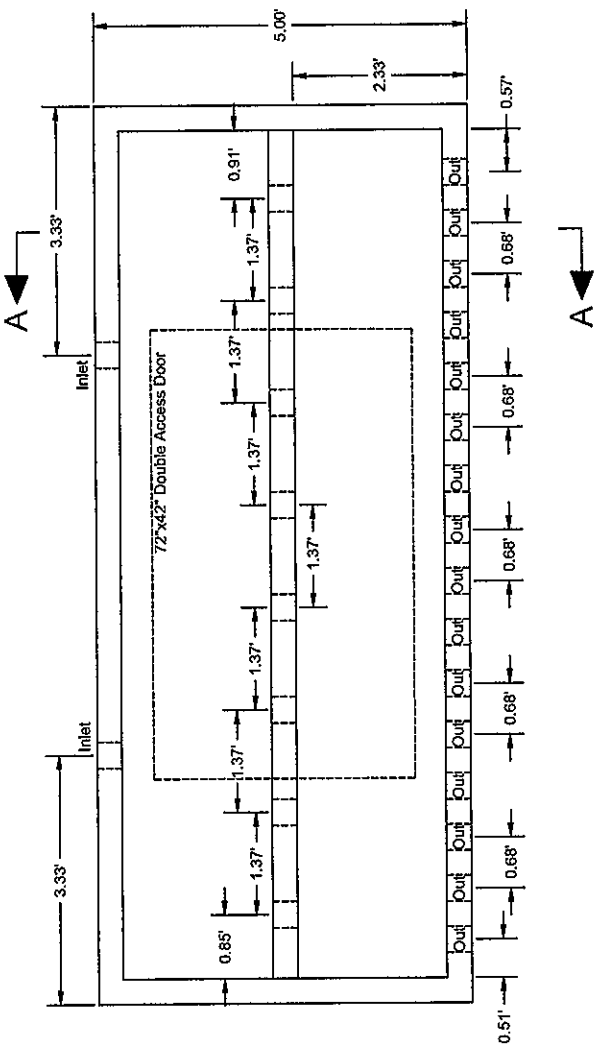

ELEVATION VIEW (OUTLET SIDE)

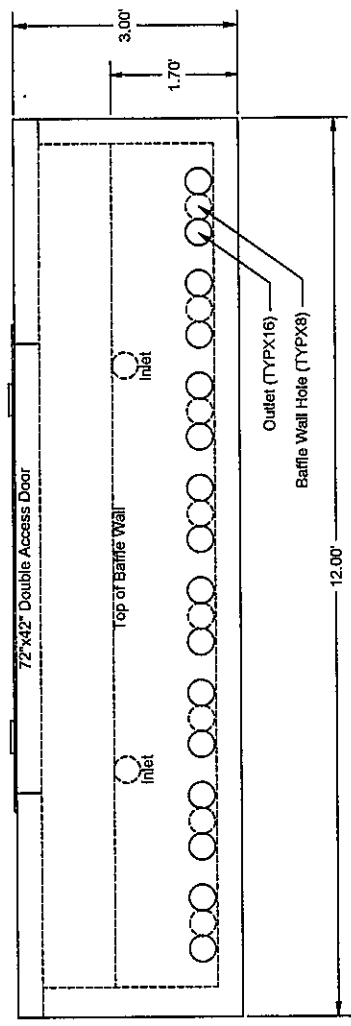

SECTION VIEW (A-A)

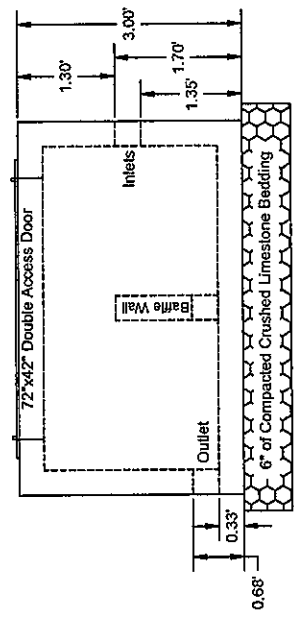

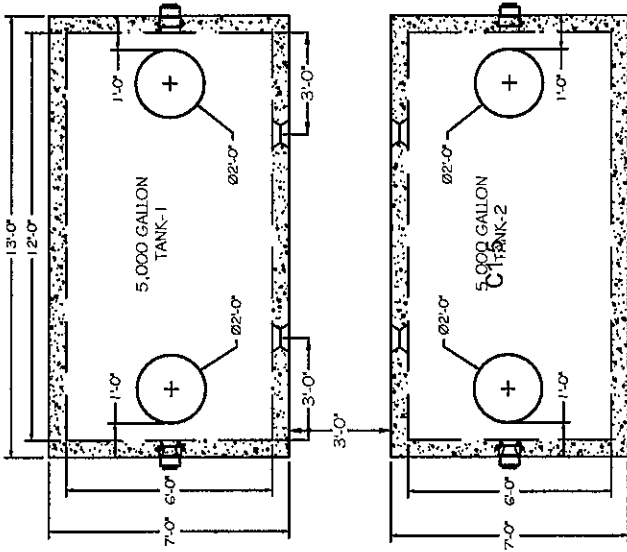

PLAN VIEW

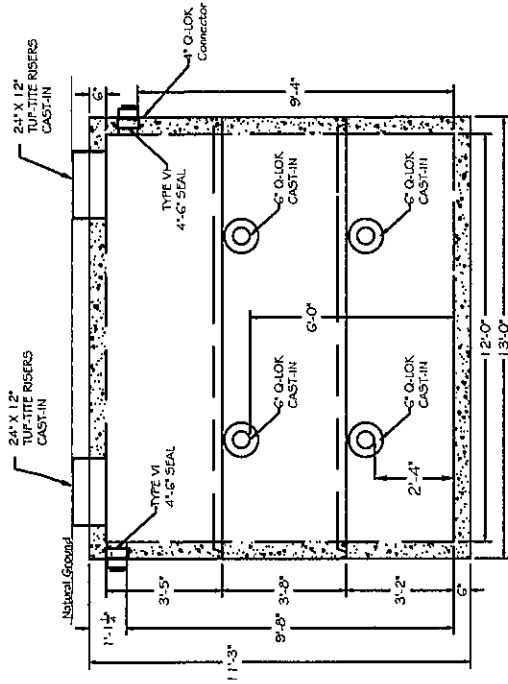

ELEVATION VIEW

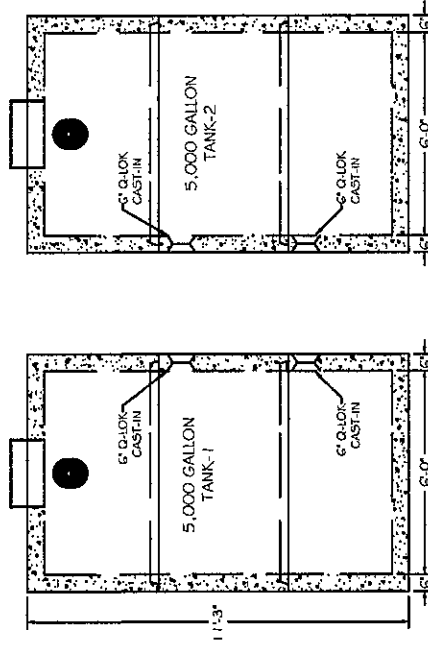

END VIEW



C1.6
SEPTIC TANK
DETAILS

SPECIFICATION: CONCRETE: 5,000 PSI CONCRETE, 28 DAYS DESIGN: MEET OR EXCEED H-20 LOAD RATING (CONCRETE GRADE RINGS/TRAFFIC RATED RING & COVERS TO BE USED IF UNIT IS INSTALLED IN TRAFFIC AREA.) PIPE CONNECTORS: MEETS OR EXCEEDS ASTM C-923, ASTM C-1644.06, AND ASTM 1227 JOINT BUTYL SEALANT: MEETS OR EXCEEDS C990 SPECIFICATIONS INTERIOR AND EXTERIOR COATINGS AVAILABLE UPON REQUEST	ESTIMATE WEIGHTS / SECTION: BOTTOM SECTION: 16,800 LBS MID SECTION: 11,500 LBS TOP SECTION: 17,200 LBS	Tank Type: 2 - 5,000 GALLON SINGLE COMP TANK	 LEE'S PRECAST CONCRETE, INC.
	DATE: 08-29-23 DRAWN BY: Allen Lee	nPCA CERTIFIED PLANT COPYRIGHT 2023 LEE'S PRECAST	



PROJECT # 2300
 DATE: 11/05/2003
 DRAWN BY: JWC
 CHECKED BY: CPC
 SCALE: 1" = 30'

NO.	DATE	DESCRIPTION

CONSTRUCTION PLANS FOR
 SOUTHEASTERN TIMBER PRODUCTS, LLC
 ACKERMAN, MISSISSIPPI
 EMERGENCY SPILLWAY

2.0
 OVERALL PLAN

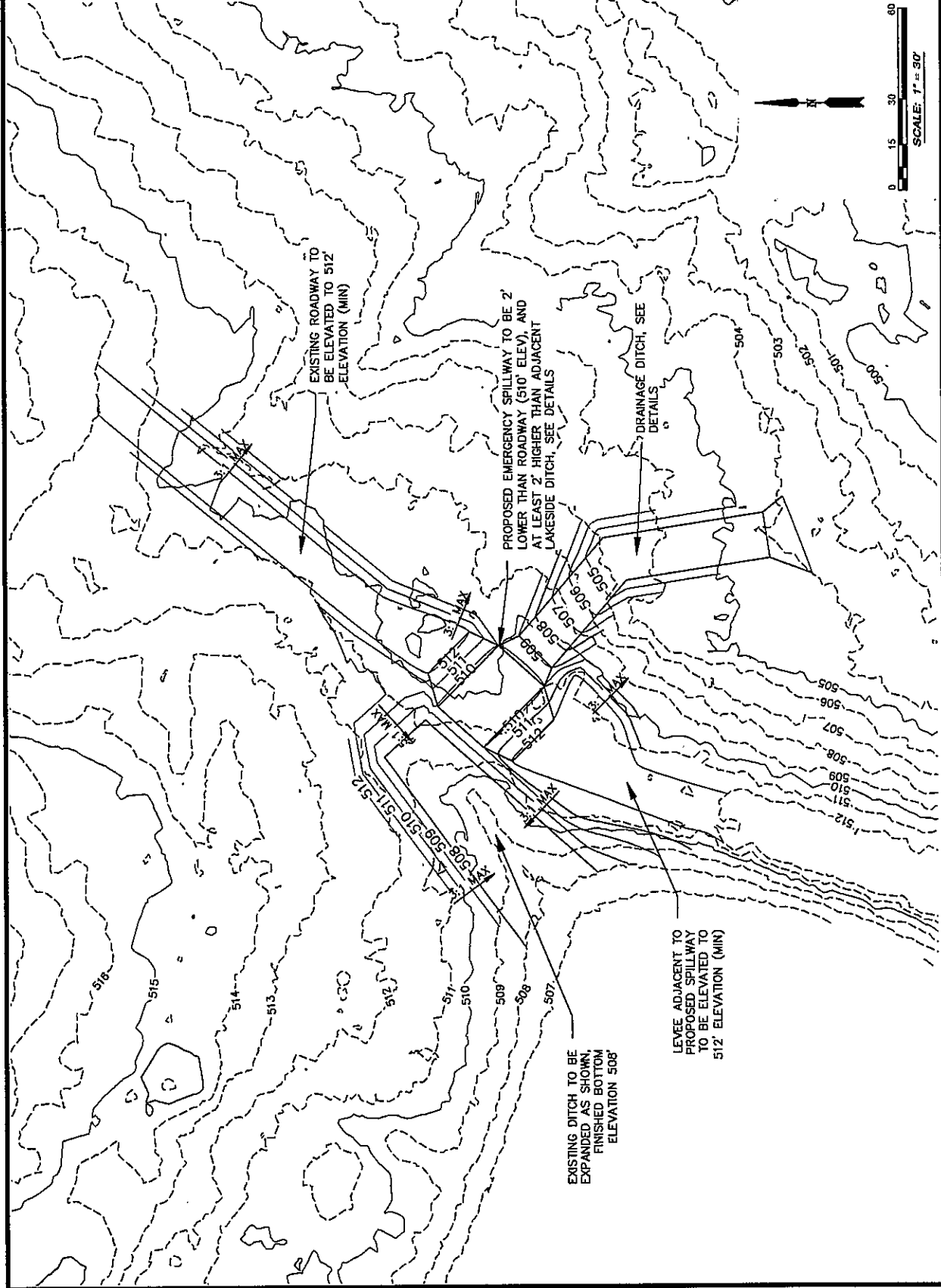



PROJECT #	2300
DATE	11/03/2023
DRAWN BY	ZM
CHECKED BY	CF
SCALE	MKS

REVISION	DATE	DESCRIPTION

CONSTRUCTION PLANS FOR
SOUTHEASTERN TIMBER PRODUCTS, LLC
ACKERMAN, MISSISSIPPI
EMERGENCY SPILLWAY

3.0

DETAILS

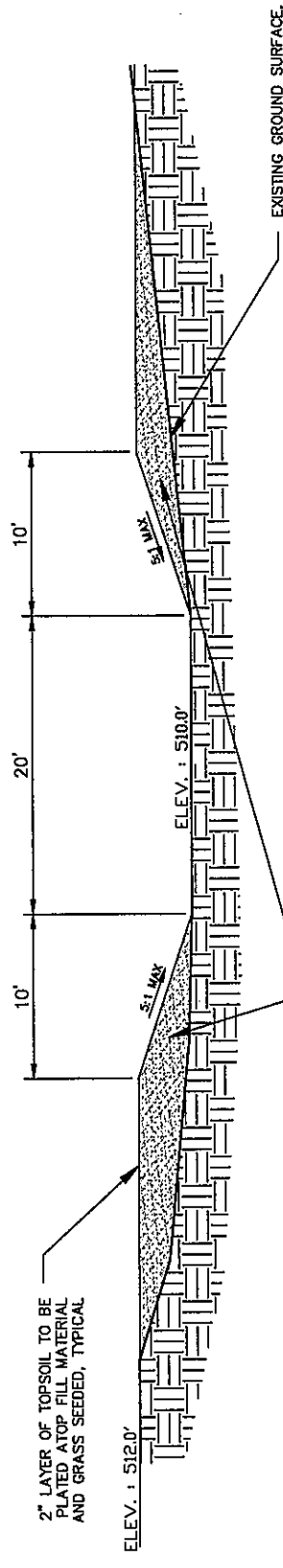

EMERGENCY SPILLWAY TYPICAL SECTION
NOT TO SCALE

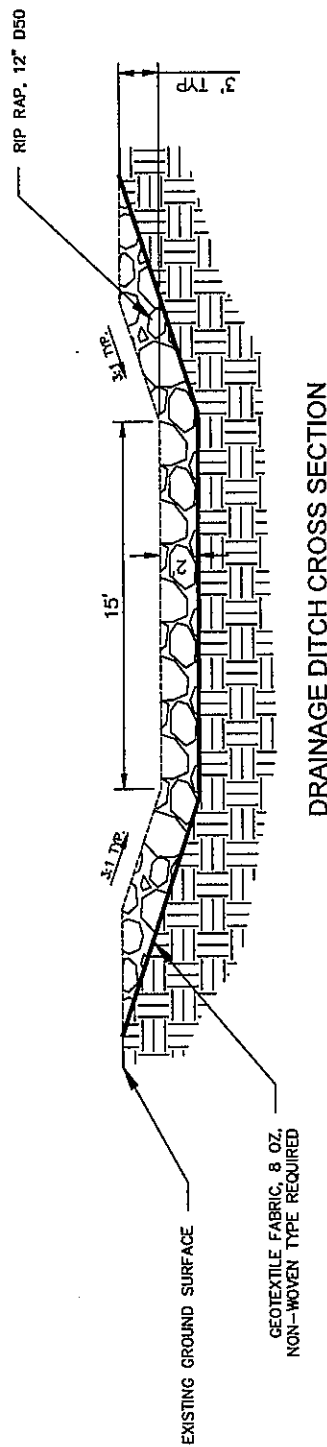

DRAINAGE DITCH CROSS SECTION
NOT TO SCALE

2" LAYER OF TOPSOIL TO BE PLATED ATOP FILL MATERIAL AND GRASS SEEDS, TYPICAL

ADDITIONAL FILL TO ELEVATE ROADWAY AND DAM EMBANKMENT. SEE FILL SPECIFICATION NOTES, THIS SHEET

EXISTING GROUND SURFACE, TOP OF SURFACE TO BE RIPPED/SCARIFIED BEFORE ADDING FILL MATERIAL

GEOTEXTILE FABRIC, 8 OZ. NON-WOVEN TYPE REQUIRED

- FILL SPECIFICATIONS
1. SELECT FILL FOR LEVEE MATERIAL SHALL CONSIST OF NON-ORGANIC AND DEBRIS-FREE SOILS CLASSIFIED AS SANDY OR SILTY CLAY (CL). SELECT FILL SHALL HAVE A LIQUID LIMIT LESS THAN 40 AND A PLASTICITY INDEX GREATER THAN 10. HORIZONTAL LOOSE LETTS HAVING A LESS THICKNESS NO GREATER THAN 9 INCHES AND COMPACTED TO NOT LESS THAN 95 PERCENT OF THE STANDARD PROCTOR MAXIMUM DRY DENSITY (ASTM D698).
 2. THE MOISTURE CONTENT OF THE SELECT FILL MATERIALS SHOULD BE WITHIN 3 PERCENT OF THE STANDARD PROCTOR MAXIMUM MOISTURE CONTENT AS DETERMINED BY THE STANDARD PROCTOR TESTS AND LABORATORY CLASSIFICATION TESTS SHALL BE PERFORMED ON SAMPLES OF SELECT FILL PRIOR TO PLACEMENT AND APPROVED IN ADVANCE BY THE ENGINEER.