



AI: 88858

Rec'd via email:
05/20/2025

MSR323088

MISSISSIPPI DEPARTMENT OF ENVIRONMENTAL QUALITY

**MINING NOTICE OF INTENT (MNOI)
FOR COVERAGE UNDER
MINING STORM WATER, DEWATERING AND NO DISCHARGE
GENERAL PERMIT MSR32 3088
(Number to be assigned by State)**

File at least 30 days prior to the commencement of mining; 15 days if a Storm Water Pollution Prevention Plan (SWPPP) is already on file and mine dewatering is not proposed. Lateral expansion of an existing mine that has general permit coverage requires the submittal of the Major Modification Form, not a new MNOI. However, modification of the existing SWPPP to include the expansion is required. Discharge of storm water or impounded water associated with mining or the operation of a wastewater recirculation system with no discharge without written notification of coverage from MDEQ is a violation of State Law.

If the company seeking coverage is a corporation, a limited liability company, a partnership, or a business trust, attach proof of its registration with the Mississippi Secretary of State and/or its Certificate of Good Standing. This registration or Certificate of Good Standing must be dated within twelve (12) months of the date of the submittal of this coverage form. Coverage will be issued in the company name as it is registered with the Mississippi Secretary of State.

Please indicate the activities to be covered by this MNOI (check all that apply).

- Storm Water Discharges Associated with Mining
- Mine Dewatering
- Wastewater Recirculation System with No Discharge

The appropriate section of the MNOI must be completed if the applicant proposes to discharge storm water, discharge impounded mine water (dewatering) and/or operate a wastewater recirculation system with no discharge.

A site-specific Storm Water Pollution Prevention Plan (SWPPP) developed in accordance with ACT5 of the General Permit and a United States Geological Survey (USGS) quadrangle map or photocopy, indicating the site location and outfalls must be included with the MNOI submittal. The name of the quadrangle map must be shown on all copies. Quadrangle maps can be obtained from the MDEQ, Office of Geology at 601-961-5523. Additional submittals may include the following (check all that apply).

- Section 404 Documentation
- Notice of Exempt Operations Form
- Dam/Reservoir Safety Permit or Written Authorization

ALL INFORMATION MUST BE COMPLETED (indicate "N/A" where not applicable)

O.C

MSR32 9064

(NUMBER TO BE ASSIGNED BY STATE)

APPLICANT IS THE: OWNER OPERATOR

OWNER CONTACT INFORMATION

OWNER CONTACT PERSON: Terry Thornton
OWNER COMPANY LEGAL NAME: Thornton Construction Co., Inc.
OWNER STREET OR P. O. BOX: 115 Bragg St.
OWNER CITY: Brandon STATE: MS ZIP: 39047
OWNER PHONE #: (601) 331-6393 OWNER EMAIL: terry@thorntonms.com

OPERATOR CONTACT INFORMATION

OPERATOR CONTACT PERSON: same as owner
OPERATOR COMPANY LEGAL NAME: _____
OPERATOR STREET OR P. O. BOX: _____
OPERATOR CITY: _____ STATE: _____ ZIP: _____
OPERATOR PHONE #: (____) _____ OPERATOR EMAIL: _____

MINE INFORMATION

MINE NAME: GFP Mine
MINE SITE ADDRESS (If the physical address is not available, please indicate nearest named road.)
Street: Grants Ferry Parkway
City: Brandon State: Mississippi County: Rankin Zip: 39042
NE _____ /4 OF SE _____ /4 OF SECTION 3, TOWNSHIP 5N, RANGE 3E
MINE SITE TRIBAL LAND ID (N/A if not applicable): N/A
ATTACH A USGS QUAD MAP, EXTENDING ½ MILE BEYOND FACILITY, OUTLINING THE MINE BOUNDARIES
(Maps can be obtained from the Mississippi Office of Geology. For information call 601-961-5523).
LATITUDE: 32 degrees 18 minutes 17.36 seconds LONGITUDE: 89 degrees 58 minutes 24.30 seconds
LAT & LONG DATA SOURCE (GPS (Please GPS Entrance Gate) or Map Interpolation): Google Earth
TOTAL ACREAGE: 33 MATERIAL TO BE MINED: Dirt
WILL HYDRAULIC DREDGING BE USED? YES NO
WASHING OF SAND/GRAVEL? YES NO

ESTIMATED START DATE: 2025-04
YYYY-MM-DD
SIC CODE 6519

ESTIMATED END DATE: 2027-12
YYYY-MM-DD
NAICS CODE 531190

RECEIVING STREAM INFORMATION

NEAREST NAMED RECEIVING STREAM: Terrapin Skin Creek

IS RECEIVING STREAM ON MISSISSIPPI'S 303(D) LIST OF IMPAIRED WATER BODIES? (The 303(d) list of impaired waters and TMDL stream segments may be found of MDEQ's website: http://www.deq.state.ms.us/MDEQ.nsf/page/TWB_Total_Maximum_Daily_Load_Section) YES NO

HAS A TMDL BEEN ESTABLISHED FOR THE RECEIVING STREAM SEGMENT? YES NO

COMPLETE IF STORM WATER DISCHARGE IS PROPOSED

ATTACH A STORM WATER POLLUTION PREVENTION PLAN (SEE PERMIT FOR REQUIREMENTS)

IDENTIFY THE ASSOCIATION OR GENERIC SWPPP ON FILE AT MDEQ: SWPPP Attached

COMPLETE IF WASTEWATER RECIRCULATION SYSTEM WITH NO DISCHARGE IS PROPOSED

DISTANCE BETWEEN RECIRCULATION POND(S) AND PROPERTY LINE: _____ (FT)
(MUST BE AT LEAST 150 FEET)

NUMBER OF RECIRCULATION POND(S): _____

STORAGE CAPACITY OF EACH RECIRCULATION POND(S): _____ (FT³)

COMPLETE IF MINE DEWATERING IS PROPOSED

ESTIMATED DEWATERING VOLUME: _____ (GAL/DAY)

NAME AND ADDRESS OF THE RECIPIENT OF THE DISCHARGE MONITORING REPORTS (DMRs), IF DIFFERENT FROM SIGNATORY: _____

DOCUMENTATION OF COMPLIANCE WITH OTHER REGULATIONS/REQUIREMENTS
Coverage under this general permit will not be granted until all other required MDEQ permits and approvals are addressed.

WILL THE CONSTRUCTION OR OPERATION OF THIS MINE INVOLVE THE RE-ROUTING, FILLING OR CROSSING OF A WATER CONVEYANCE OF ANY KIND? YES NO

If yes, contact the U.S. Army Corps of Engineers' Regulatory Branch for permitting requirements. If the mine requires a Corps of Engineers Section 404 permit, provide appropriate documentation with this MNOI that:

- The mine has been approved by individual permit, or
- The work will be covered by a nationwide permit and NO NOTIFICATION to the Corps is required, or
- The work will be covered by a nationwide or general permit and NOTIFICATION to the Corps is required.

LIST ANY NPDES PERMIT NO(s) N/A GEOLOGY APPLICATION/PERMIT NO. N/A

LIST OTHER GEOLOGY PERMIT NUMBERS THAT APPLY TO COVERAGE AREA N/A

IS THE MINE LESS THAN 4 ACRES AND GREATER THAN 1320 FEET FROM ANOTHER MINE?

- YES A "Notice of Exempt Operations" Form must be included with the MNOI or proof of prior submission, if previously submitted to the Office of Geology.
- NO A "Notice of Intent to Mine Class I or Class II Materials" Form must be filed before coverage will be granted under the Mining General Permit. For information on Office of Geology requirements, call 601-961-5515.

LIST ANY LOCAL STORM WATER ORDINANCES WITH WHICH THE OPERATIONS MUST COMPLY AND SUBMIT ANY ASSOCIATED APPROVAL DOCUMENTATION. City of Brandon Ordinances

IF IMPOUNDMENTS WILL BE CONSTRUCTED ABOVE NATURAL SURFACE ELEVATIONS, INDICATE WHICH, IF ANY, OF THE FOLLOWING APPLY.

- The impoundment will be constructed with a peripheral dam or levee 8 feet or greater in height, measured from the lowest elevation of its toe.
- The impoundment will have a maximum storage volume greater than 25 acre-feet.
- The impoundment will impound a watercourse with a continuous flow.
- The impoundment has the potential to threaten downstream lives or man-made structures.

If any of the impoundments meet any of the above criteria, the applicant will be required to obtain written authorization from MDEQ, Dam Safety Division before coverage will be granted under the Mining General Permit.

I certify under penalty of law that this document and all attachments were prepared under my direction or supervision in accordance with a system designed to assure that qualified personnel properly gathered and evaluated the information submitted. Based on my inquiry of the person or persons who manage the system, or those persons directly responsible for gathering the information, the information submitted is, to the best of my knowledge and belief, true, accurate and complete. I am aware that there are significant penalties for submitting false information, including the possibility of fine and imprisonment for knowing violations.

 3/4/2025
Authorized Signature¹ Date
Terry Thornton President
Printed Name Title

¹This application shall be signed according to the General Permit, Act 15, T-4 as follows:

- For a corporation, by a responsible corporate officer.
- For a partnership, by a general partner.
- For a sole proprietorship, by the proprietor.
- For a municipal, state or other public facility, by either a principal executive officer, the mayor, or ranking elected official.
- Duly Authorized Representative

Please submit this form to: Chief, Environmental Permits Division
MDEQ, Office of Pollution Control
P.O. Box 2261
Jackson, Mississippi 39225

Storm Water Pollution Prevention Plan

For

GFP MINE

Located in
Rankin County, Mississippi



CIVIL CONSULTING ENGINEERING ♦ LAND SURVEYING ♦ UAV MAPPING

www.benchmarkms.net

Site Information

The Grants Ferry Mine is located on Grants Ferry Road in Rankin County, MS. Dirt will be mined from this location and sold to contractors for construction projects in the area. The mine permit area is 31 acres, a mining permit is being submitted to the Office of Geology for approval.

According to the SOIL SURVEY OF RANKING COUNTY, MISSISSIPPI the soil on the site is of 41C2 – Providence silt loam, 5 to 8 percent slopes, moderately eroded, moderately well drained. 65D – Smithdale – Providence complex, 8 to 17 percent slopes, well drained. The topography is hilly, characterized by steep side slopes that are dissected by numerous short drainageways. This site drains to Terrapin Skin Creek.

Vegetative Controls

Topsoil will be stockpiled on site as needed for reclamation. Contractor will be allowed to stockpile other soils for mixing purposes. Silt fencing shall be placed around any stockpiles that are at a grade where runoff may leave the project site. Any disturbed areas that will drain off of project site that are thought to remain undisturbed for thirty or more days will be seeded with permanent or temporary seeding immediately (within seven calendar days).

Structural Controls

Upslope waters will be diverted around disturbed areas if encountered. Silt fence or brush barriers will be installed along the toe of all slopes where the grade will direct storm water runoff away from the project site. Additional fencing and brush barriers will be added as required to control sediment.

Housekeeping Practices

An equipment/materials staging area will be constructed, location to be decided by the contractor. A suitable container for trash will be provided. Trash receptacles will be collected regularly by the applicant. Portable sanitary facilities will be provided for the construction workers. An existing access drive will be utilized for construction access to the site. All major equipment maintenance and repair will be done offsite. In the event that minor equipment maintenance and repair is required onsite, it will be performed in the equipment/materials staging area. Refueling of equipment will take place in the equipment/materials staging area. Portable sanitary facilities will be inspected by the contractor weekly and emptied or replaced as needed. The equipment/materials staging area will be inspected by the contractor weekly and after storm events; perimeter controls, containment structures and covers will be repaired or replaced as needed.

Post Construction/Storm Water Management Measures

Hay bales, wattles or rip-rap will be placed at concentrated storm water discharge points to prevent erosion from high velocities until permanent ground cover is established should there be any such situations, however we do not anticipate this situation at this time. Silt fence will be placed as necessary to impede silt laden runoff from leaving the site.

Implementation Sequence

1. Install sanitary sewer facilities and trash containers.
2. Set up equipment and materials staging area for project.
3. Install silt fence & brush barriers along downstream end of area to be disturbed.
4. Begin mining & grading operations.
5. Stabilize the project site with permanent seed and mulch.
6. Remove all temporary erosion control measures once site is stabilized with 90% vegetative cover.

Maintenance Plan

All erosion control and outfall/discharge points are to be inspected a minimum of once per month and after rain events. Make needed repairs within 24 hours or as soon as conditions allow. Remove sediment from the silt fences when accumulated sediment has reached 50% capacity. Replace non-functional silt fence. Maintain all vegetated areas to provide proper ground cover – reseed, fertilize and mulch as needed. Remove all erosion control measures once contributing area is stabilized.

Custom Soil Resource Report Soil Map



Map Scale: 1:3,500 if printed on A landscape (11" x 8.5") sheet.

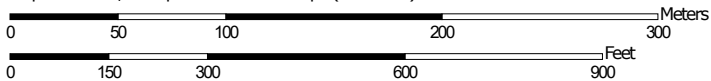

Map projection: Web Mercator Corner coordinates: WGS84 Edge tics: UTM Zone 16N WGS84

MAP LEGEND

Area of Interest (AOI)

 Area of Interest (AOI)

Soils

 Soil Map Unit Polygons

 Soil Map Unit Lines

 Soil Map Unit Points

Special Point Features





-  Blowout
-  Borrow Pit
-  Clay Spot
-  Closed Depression
-  Gravel Pit
-  Gravelly Spot
-  Landfill
-  Lava Flow
-  Marsh or swamp
-  Mine or Quarry
-  Miscellaneous Water
-  Perennial Water
-  Rock Outcrop
-  Saline Spot
-  Sandy Spot
-  Severely Eroded Spot
-  Sinkhole
-  Slide or Slip
-  Sodic Spot

-  Spoil Area
-  Stony Spot
-  Very Stony Spot
-  Wet Spot
-  Other
-  Special Line Features

Water Features

 Streams and Canals

Transportation

-  Rails
-  Interstate Highways
-  US Routes
-  Major Roads
-  Local Roads

Background

 Aerial Photography

MAP INFORMATION

The soil surveys that comprise your AOI were mapped at 1:20,000.

Warning: Soil Map may not be valid at this scale.

Enlargement of maps beyond the scale of mapping can cause misunderstanding of the detail of mapping and accuracy of soil line placement. The maps do not show the small areas of contrasting soils that could have been shown at a more detailed scale.

Please rely on the bar scale on each map sheet for map measurements.

Source of Map: Natural Resources Conservation Service
 Web Soil Survey URL:
 Coordinate System: Web Mercator (EPSG:3857)

Maps from the Web Soil Survey are based on the Web Mercator projection, which preserves direction and shape but distorts distance and area. A projection that preserves area, such as the Albers equal-area conic projection, should be used if more accurate calculations of distance or area are required.

This product is generated from the USDA-NRCS certified data as of the version date(s) listed below.

Soil Survey Area: Rankin County, Mississippi
 Survey Area Data: Version 20, Sep 6, 2024

Soil map units are labeled (as space allows) for map scales 1:50,000 or larger.

Date(s) aerial images were photographed: Nov 8, 2021—Nov 29, 2021

The orthophoto or other base map on which the soil lines were compiled and digitized probably differs from the background imagery displayed on these maps. As a result, some minor shifting of map unit boundaries may be evident.

Map Unit Legend

Map Unit Symbol	Map Unit Name	Acres in AOI	Percent of AOI
41C2	Providence silt loam, 5 to 8 percent slopes, moderately eroded	9.4	30.6%
65D	Smithdale-Providence complex, 8 to 17 percent slopes	21.3	69.4%
Totals for Area of Interest		30.7	100.0%

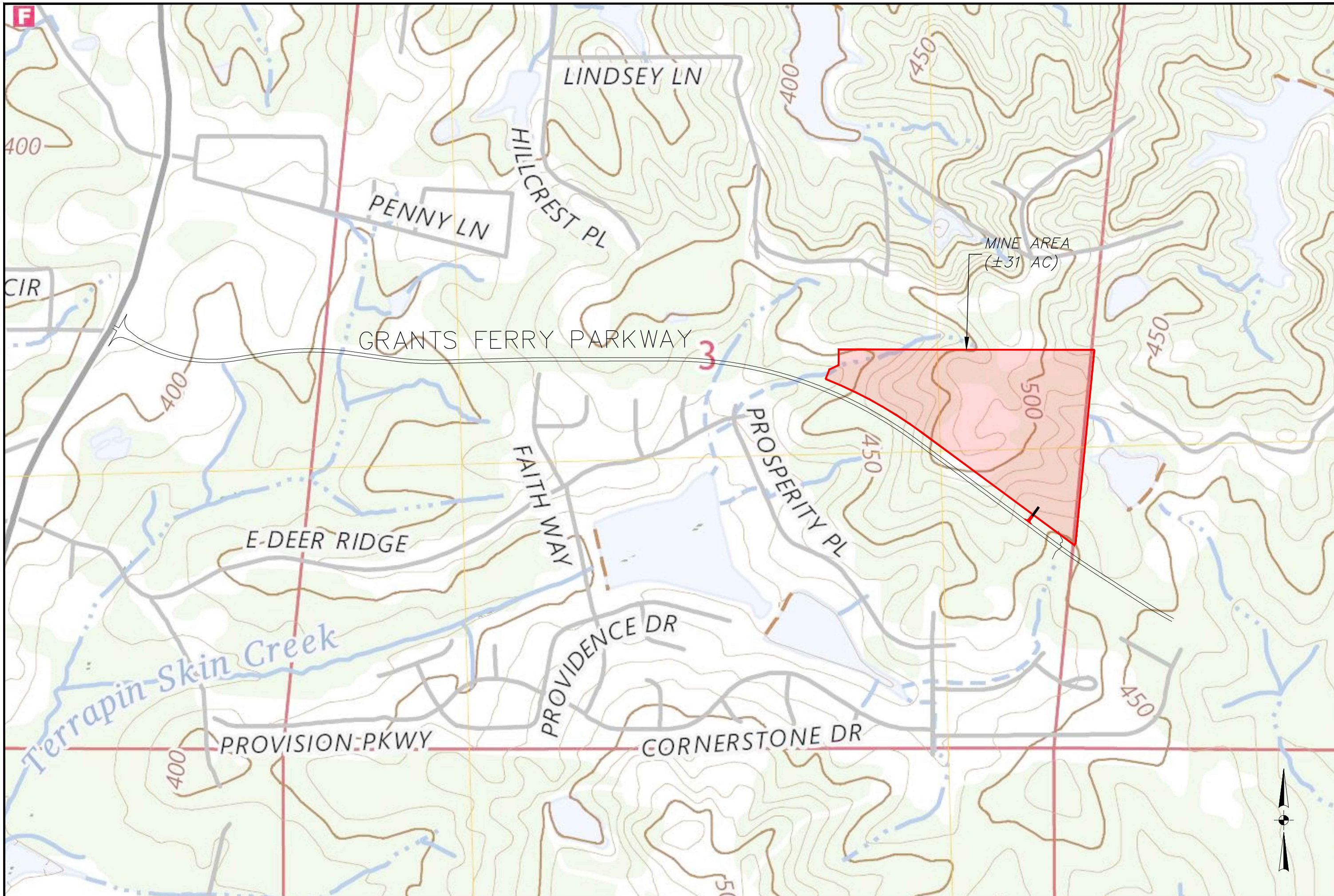

DATE: 12/20/24	DRAWN: WCG	REVISIONS:
CHECKED: GAB	SCALE: NTS	
REF: C/L	EG SURFACE:	
	FG SURFACE:	







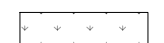

PROJECT LOCATION: GRANTS FERRY ROAD RANKIN COUNTY, MS
CLIENT: THORNTON CONSTRUCTION CO., INC. 115 BRAGG ST., BRANDON, MS 39047-8575

PROJECT: GFP MINE
SHEET CONTENTS: QUAD MAP

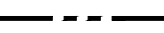
SHEET NUMBER 1 of 3
PROJECT NUMBER B-10417

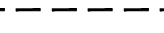
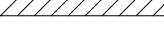

LEGEND

-  GRASSING REQ'D.
-  PROPOSED LAKE
-  MINING PERMIT AREA
-  SILT FENCE REQ'D.
-  BRUSH BARRIER REQ'D.
-  APPROX. RIDGELINE
-  BUFFER ZONE REQ'D.
-  EX. PERENNIAL STREAM
-  EX. INTERMITTENT STREAM
-  EX. WETLAND
-  EX. DRAIN PATH

CONSTRUCTION SEQUENCE & EROSION CONTROL SEQUENCE SCHEDULE

THE SCHEDULE LAID OUT BELOW IS TO PROVIDE CLARIFICATION TO THE CONTRACTOR ON THE INTENDED ORDER OF CONSTRUCTION IN CONJUNCTION WITH THE REQUIRED EROSION CONTROL MEASURES OF THIS PROJECT AS SHOWN ON THIS SHEET AND OTHER CONTRACT DOCUMENTS.

1. INSTALL SANITARY SEWER FACILITIES AND TRASH CONTAINERS.
2. SET UP EQUIPMENT AND MATERIALS STAGING AREA FOR PROJECT.
3. INSTALL SILT FENCE & BRUSH BARRIERS ALONG THE DOWNSTREAM BOUNDARY OF ANY AREAS THAT ARE TO BE GRADED OR MINED.
4. BEGIN MINING & GRADING OPERATIONS.
5. STABILIZE THE PROJECT SITE WITH PERMANENT SEED AND MULCH IN AREAS THAT ARE GRADED OR MINED.
6. REMOVE ALL TEMPORARY EROSION CONTROL MEASURES ONCE SITE IS STABILIZED WITH 90% VEGETATIVE COVER.

NOTES:

1. IT IS THE INTENT OF THIS PLAN THAT THE CONTRACTOR SHALL INSTALL SILT FENCING, BRUSH BARRIERS, OR OTHER MDEQ ACCEPTED BMP'S (OR A COMBINATION OF SUCH) ON THE DOWNSTREAM PERIMETER OF ANY AREAS THAT ARE TO BE CLEARED/GRUBBED OR MINED PRIOR TO BEGINNING WORK TO CONTROL EROSION AND SILT RUNOFF PER MDEQ REQUIREMENTS.
2. TOPSOIL AND GRASSING WILL BE REQUIRED IN THE EXCAVATED AREA AS PART OF THE RECLAMATION PLAN.
3. TOPSOIL STOCKPILE LOCATIONS WILL BE DETERMINED BY THE CONTRACTOR.
4. SILT FENCE SHALL SURROUND EACH TOPSOIL STOCKPILE LOCATION.
5. EQUIPMENT STAGING AREA WILL BE DETERMINED THE CONTRACTOR.
6. NOT ALL EROSION CONTROL ITEMS REQUIRED AT ONCE, ONLY IN AREAS THAT IS BEING DISTURBED AT THAT TIME.
7. PROPOSED LAKE SHOWN SHALL BE CONSIDERED APPROXIMATE, SIZE AND SHAPE SUBJECT TO CHANGE.

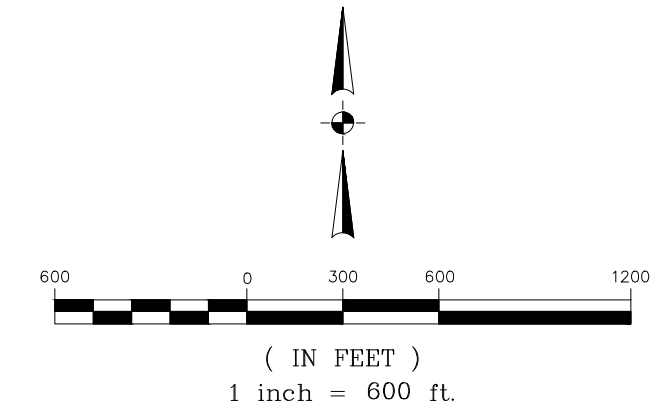



BENCHMARK
ENGINEERING & SURVEYING, LLC
CIVIL • STRUCTURAL • PLANNING • SURVEYING • UAV MAPPING
BRANDON | FLOWOOD | MADISON
www.benchmark.net
EST. 2004

DATE: 12/20/24	DRAWN: WCG	REVISIONS:	SCALE: 600
CHECKED: CBA	PROJECT LOCATION:	REF. C/L:	EG SURFACE:
EG SURFACE:	GRANTS FERRY ROAD	EG SURFACE:	EG SURFACE:
EG SURFACE:	RANKIN COUNTY, MS	EG SURFACE:	EG SURFACE:
EG SURFACE:	CLIENT:	EG SURFACE:	EG SURFACE:
EG SURFACE:	THORNTON CONSTRUCTION CO., INC.	EG SURFACE:	EG SURFACE:
EG SURFACE:	P.O. BOX 2235, CLINTON, MS 39060-2235	EG SURFACE:	EG SURFACE:

PROJECT: **GFP MINE**

SHEET CONTENTS: **EROSION CONTROL PLAN**

SHEET NUMBER

2 of 3

PROJECT NUMBER

B-10417

DATE: 12/20/24	DRAWN: CBA
CHECKED: GAB	SCALE:
REF: C/L	EG SURFACE:
	FG SURFACE:

PROJECT LOCATION:
 GRANT'S FERRY ROAD
 RANKIN COUNTY, MS
 CLIENT:
 THORNTON CONSTRUCTION CO., INC.
 115 BRAGG ST., BRANDON, MS 39047-8575

PROJECT:
GFP MINE
 SHEET CONTENTS:
EROSION CONTROL DETAILS

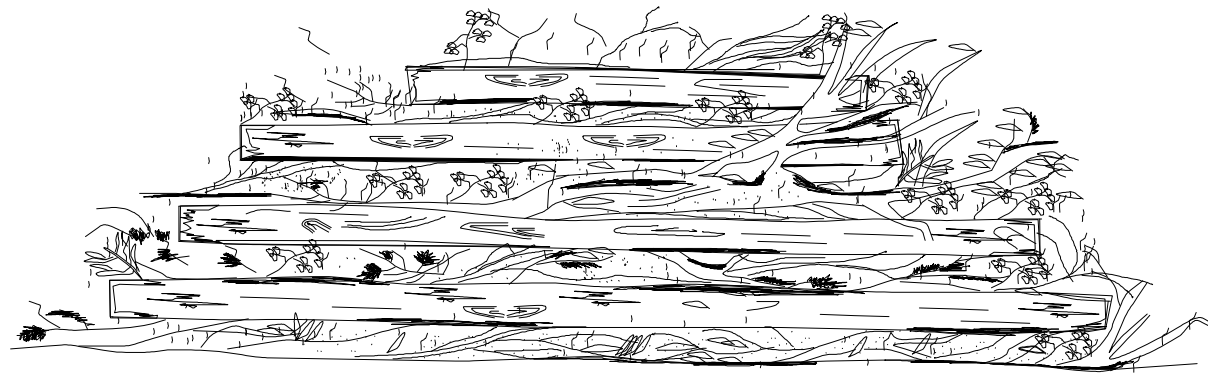

FRONT ELEVATION

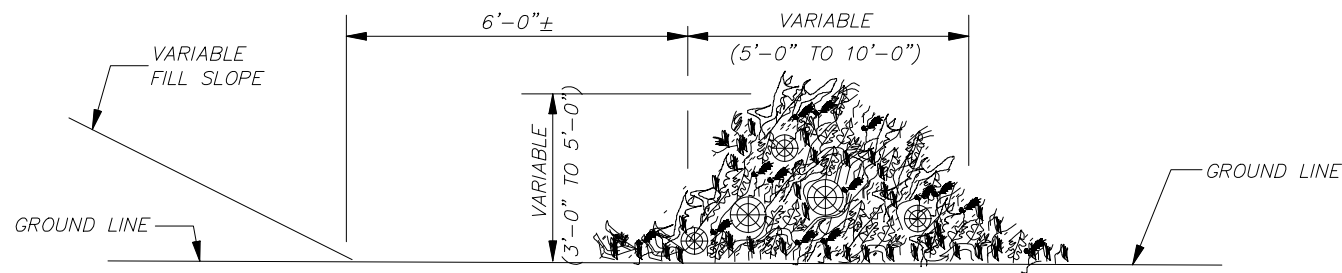

SIDE ELEVATION

NOTES:

- BRUSH BARRIER TO BE USED WHERE NATURAL GROUND COVER IS LEVEL OR SLOPING AWAY FROM PROJECT.
- PLACE BRUSH, LOG AND TREE LAPS APPROXIMATELY PARALLEL TO TOE OF FILL SLOPE WITH SOME OF THE HEAVIER MATERIALS BEING PLACED ON TOP TO PROPERLY SECURE THE BARRIER AS DETAILED AT LOCATIONS SHOWN ON THE PLANS OR AS DIRECTED BY THE ENGINEER.
- TO ALLOW WATER TO FLOW THROUGH THE BRUSH BARRIER, INTERMINGLE THE BRUSH, LOG AND TREE LAPS SO AS NOT TO FORM A SOLID DAM.

TEMPORARY BRUSH BARRIER

N.T.S.

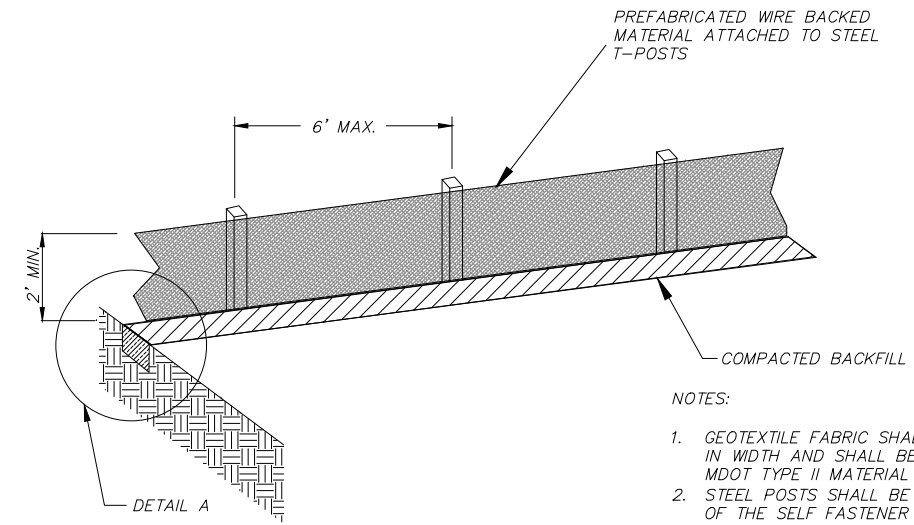

SILT FENCE DETAIL

NOTES:

- GEOTEXTILE FABRIC SHALL BE A MINIMUM OF 36" IN WIDTH AND SHALL BE WIRE BACKED OR MEET MDOT TYPE II MATERIAL REQUIREMENTS.
- STEEL POSTS SHALL BE 4' (MIN.) IN HEIGHT AND OF THE SELF FASTENER ANGLE STEEL TYPE.
- FENCE SHALL BE FASTENED WITH NOT LESS THAN 9 GAGE STAPLES 1" LONG FOR WOODEN POSTS AND 3/4" FOR WOODEN STAKES.
- ALLOW A 6" OVERLAP OF FABRIC AT JOINTS.

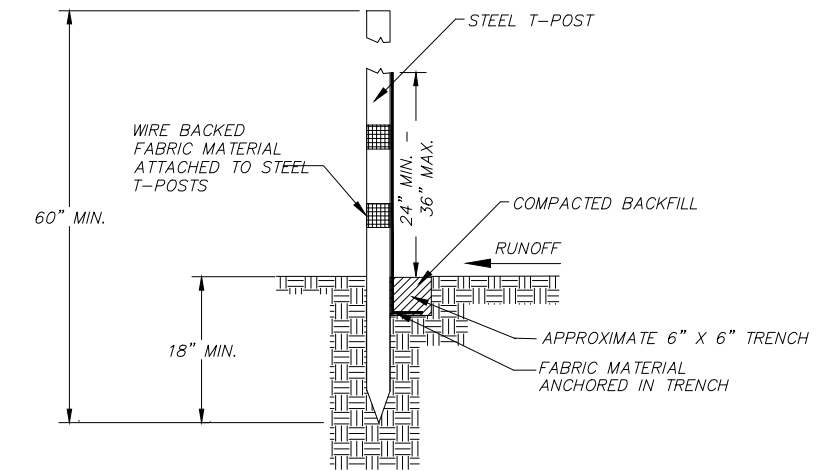

SILT FENCE DETAILS

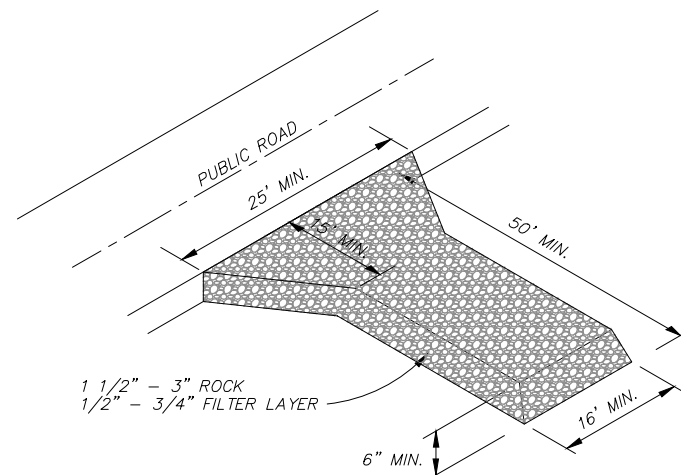

NOTES:

- VEHICLE TRACKING MAT SHALL BE LOCATED AT EVERY ENTRANCE/EXIT TO THE CONSTRUCTION SITE.
- VEHICLE TRACKING MAT SHALL BE MAINTAINED BY CONTRACTOR AS NEEDED TO PREVENT ANY MATERIAL FROM BEING TRACKED ONTO PUBLIC ROAD.
- SEDIMENT AND OTHER MATERIAL SPILLED, DROPPED OR TRACKED ONTO PUBLIC ROAD SHALL BE IMMEDIATELY REMOVED BY CONTRACTOR.

TEMPORARY CONSTRUCTION ENTRANCE DETAIL