



MISSISSIPPI DEPARTMENT OF
ENVIRONMENTAL QUALITY

LARGE CONSTRUCTION NOTICE OF INTENT (LCNOI) FOR COVERAGE UNDER THE LARGE CONSTRUCTION STORM WATER GENERAL NPDES PERMIT

INSTRUCTIONS

The Large Construction Notice of Intent (LCNOI) is for coverage under the Large Construction General Permit for land disturbing activities of five (5) acres or greater; or for land disturbing activities, which are part of a larger common plan of development or sale that are initially less than five (5) acres but will ultimately disturb five (5) or more acres. Applicant must be the owner or operator. For construction activities, the operator is typically the prime contractor. The owner(s) of the property and the prime contractor associated with regulated construction activity on the property have joint and severable responsibility for compliance with the Large Construction Storm Water General Permit MSR10.

If the company seeking coverage is a corporation, a limited liability company, a partnership, or a business trust, attach proof of its registration with the Mississippi Secretary of State and/or its Certificate of Good Standing. This registration or Certificate of Good Standing must be dated within twelve (12) months of the date of the submittal of this coverage form. Coverage will be issued in the company name as it is registered with the Mississippi Secretary of State.

Completed LCNOIs should be filed at least thirty (30) days prior to the commencement of construction. Discharge of storm water from large construction activities without written notification of coverage is a violation of state law.

Submittals with this LCNOI must include:

- A site-specific Storm Water Pollution Prevention Plan (SWPPP) developed in accordance with ACT5 of the General Permit
- A detailed site-specific scaled drawing showing the property layout and the features outlined in ACT5 of the General Permit
- A United States Geological Survey (USGS) quadrangle map or photocopy, extending at least one-half mile beyond the facility property boundaries with the site location and outfalls outlined or highlighted. The name of the quadrangle map must be shown on all copies. Quadrangle maps can be obtained from the MDEQ, Office of Geology at 601-961-5523.

Additional submittals may include the following, if applicable:

- Appropriate Section 404 documentation from U.S. Army Corps of Engineers
- Appropriate documentation concerning future disposal of sanitary sewage and sewage collection system construction
- Appropriate documentation from the MDEQ Office of Land & Water concerning dam construction and low flow requirements
- Approval from County Utility Authority in Hancock, Harrison, Jackson, Pearl River and Stone Counties
- Antidegradation report for disturbance within Waters of the State

ALL QUESTIONS MUST BE ANSWERED (Answer "NA" if the question is not applicable)

MSR10 9908 _____

(NUMBER TO BE ASSIGNED BY STATE)

APPLICANT IS THE: OWNER PRIME CONTRACTOR

OWNER CONTACT INFORMATION

OWNER CONTACT PERSON: Rodney Grogan
 OWNER COMPANY LEGAL NAME: MMC Materials, Inc.
 OWNER STREET OR P.O. BOX: 133 New Ragsdale Road
 OWNER CITY: Madison STATE: Mississippi ZIP: 39110
 OWNER PHONE #: (601) 898-4000 OWNER EMAIL: rgrogan@mmcmaterials.com

PREPARER CONTACT INFORMATION

IF NOI WAS PREPARED BY SOMEONE OTHER THAN THE APPLICANT

CONTACT PERSON: Zach Byrd
 COMPANY LEGAL NAME: Wages Civil, LLC
 STREET OR P.O. BOX: 276 Nissan Parkway Building B Suite 300
 CITY: Canton STATE: MS ZIP: 39046
 PHONE # () 601-559-4571 EMAIL: zbyrd@wagescivil.com

PRIME CONTRACTOR CONTACT INFORMATION

PRIME CONTRACTOR CONTACT PERSON: _____
 PRIME CONTRACTOR COMPANY LEGAL NAME: _____
 PRIME CONTRACTOR STREET OR P.O. BOX: _____
 PRIME CONTRACTOR CITY: _____ STATE: _____ ZIP: _____
 PRIME CONTRACTOR PHONE #: () _____ PRIME CONTRACTOR EMAIL: _____

FACILITY SITE INFORMATION

FACILITY SITE NAME: MMC Training Center
 FACILITY SITE ADDRESS (If the physical address is not available, please indicate the nearest named road. For linear projects indicate the beginning of the project and identify all counties the project traverses.)
 STREET: Cloverleaf Dr
 CITY: Canton STATE: MS COUNTY: Madison ZIP: 39046
 FACILITY SITE TRIBAL LAND ID (N/A If not applicable): N/A
 LATITUDE: 32 degrees 33 minutes 07 seconds LONGITUDE: 90 degrees 04 minutes 58 seconds
 LAT & LONG DATA SOURCE (GPS (Please GPS Project Entrance/Start Point) or Map Interpolation): GOOGLE EARTH
 TOTAL ACREAGE THAT WILL BE DISTURBED ¹: 17.55

IS THIS PART OF A LARGER COMMON PLAN OF DEVELOPMENT? YES NO

IF YES, NAME OF LARGER COMMON PLAN OF DEVELOPMENT: _____
 AND PERMIT COVERAGE NUMBER: MSR10_ _ _ _ _

ESTIMATED CONSTRUCTION PROJECT START DATE: 2026-7-26
 YYYY-MM-DD

ESTIMATED CONSTRUCTION PROJECT END DATE: 2027-02-27
 YYYY-MM-DD

DESCRIPTION OF CONSTRUCTION ACTIVITY: _____

PROPOSED DESCRIPTION OF PROPERTY USE AFTER CONSTRUCTION HAS BEEN COMPLETED:
 Training center for MMC Materials

SIC Code: 8 2 9 9 NAICS Code 6 1 1 4 3 0⁺

NEAREST NAMED RECEIVING STREAM: Bear Creek

IS RECEIVING STREAM ON MISSISSIPPI'S 303(d) LIST OF IMPAIRED WATER BODIES? (The 303(d) list of impaired waters and TMDL stream segments may be found on MDEQ's web site: http://www.deq.state.ms.us/MDEQ.nsf/page/TWB_Total_Maximum_Daily_Load_Section) YES NO

HAS A TMDL BEEN ESTABLISHED FOR THE RECEIVING STREAM SEGMENT? YES NO

FOR WHICH POLLUTANT:

ARE THERE RECREATIONAL STREAMS, PRIVATE/PUBLIC PONDS OR LAKES WITHIN 1/2 MILE DOWNSTREAM OF PROJECT BOUNDARY THAT MAY BE IMPACTED BY THE CONSTRUCTION ACTIVITY? YES NO

EXISTING DATA DESCRIBING THE SOIL (for linear projects please describe in SWPPP): _____

WILL FLOCCULANTS BE USED TO TREAT TURBIDITY IN STORM WATER? YES NO

IF YES, INDICATE THE TYPE OF FLOCCULANT. ANIONIC POLYACRYLAMIDE (PAM)
 OTHER _____

IF YES, DOES THE SWPPP DESCRIBE THE METHOD OF INTRODUCTION, THE LOCATION OF INTRODUCTION AND THE LOCATION OF WHERE FLOCCULATED MATERIAL WILL SETTLE?

IS A SDS SHEET INCLUDED FOR THE FLOCCULATE? YES NO

WILL THERE BE A 50 FT BUFFER BETWEEN THE PROJECT DISTURBANCE AND THE WATERS OF THE STATE? YES NO

IF NOT, PROVIDE EQUIVALENT CONTROL MEASURES IN THE SWPPP.

¹Acreage for subdivision development includes areas disturbed by construction of roads, utilities and drainage. Additionally, a housesite of at least 10,000 ft² per lot (entire lot, if smaller) shall be included in calculating acreage disturbed.

DOCUMENTATION OF COMPLIANCE WITH OTHER REGULATIONS/REQUIREMENTS
 COVERAGE UNDER THIS PERMIT WILL NOT BE GRANTED UNTIL ALL OTHER REQUIRED
 MDEQ PERMITS AND APPROVALS ARE SATISFACTORILY ADDRESSED

IS LCNOI FOR A FACILITY THAT WILL REQUIRE OTHER PERMITS? YES NO

IF YES, CHECK ALL THAT APPLY: AIR HAZARDOUS WASTE PRETREATMENT
 WATER STATE OPERATING INDIVIDUAL NPDES OTHER: _____

IS THE PROJECT REROUTING, FILLING OR CROSSING A WATER CONVEYANCE OF ANY KIND? (If yes, contact the U.S. Army Corps of Engineers' Regulatory Branch for permitting requirements.) YES NO

IF THE PROJECT REQUIRES A CORPS OF ENGINEER SECTION 404 PERMIT, PROVIDE APPROPRIATE DOCUMENTATION THAT:

- The project has been approved by individual permit, or
- The work will be covered by a nationwide permit and NO NOTIFICATION to the Corps is required, or
- The work will be covered by a nationwide or general permit and NOTIFICATION to the Corps is required

IS THE PROJECT REROUTING, FILLING OR CROSSING A STATE WATER CONVEYANCE OF ANY KIND? (If yes, please provide an antidegradation report.) YES NO

IS A LAKE REQUIRING THE CONSTRUCTION OF A DAM BEING PROPOSED? (If yes, provide appropriate approval documentation from MDEQ Office of Land and Water, Dam Safety.) YES NO

IF THE PROJECT IS A SUBDIVISION OR A COMMERCIAL DEVELOPMENT, HOW WILL SANITARY SEWAGE BE DISPOSED? Check one of the following and attach the pertinent documents.

- Existing Municipal or Commercial System. Please attach plans and specifications for the collection system and the associated "Information Regarding Proposed Wastewater Projects" form or approval from County Utility Authority in Hancock, Harrison, Jackson, Pearl River and Stone Counties. If the plans and specifications can not be provided at the time of LCNOI submittal, MDEQ will accept written acknowledgement from official(s) responsible for wastewater collection and treatment that the flows generated from the proposed project can and will be transported and treated properly. The letter must include the estimated flow.
- Collection and Treatment System will be Constructed. Please attach a copy of the cover of the NPDES discharge permit from MDEQ or indicate the date the application was submitted to MDEQ (Date: _____.)
- Individual Onsite Wastewater Disposal Systems for Subdivisions Less than 35 Lots. Please attach a copy of the Letter of General Acceptance from the Mississippi State Department of Health or certification from a registered professional engineer that the platted lots should support individual onsite wastewater disposal systems.
- Individual Onsite Wastewater Disposal Systems for Subdivisions Greater than 35 Lots. A determination of the feasibility of installing a central sewage collection and treatment system must be made by MDEQ. A copy of the response from MDEQ concerning the feasibility study must be attached. If a central collection and wastewater system is not feasible, then please attach a copy of the Letter of General Acceptance from the State Department of Health or certification from a registered professional engineer that the platted lots should support individual onsite wastewater disposal systems.

INDICATE ANY LOCAL STORM WATER ORDINANCE (I.E. MS4) WITH WHICH THE PROJECT MUST COMPLY:

I certify under penalty of law that this document and all attachments were prepared under my direction or supervision in accordance with a system designed to assure that qualified personnel properly gathered and evaluated the information submitted. Based on my inquiry of the person or persons who manage the system, or those persons directly responsible for gathering the information, the information submitted is, to the best of my knowledge and belief, true, accurate and complete. I am aware that there are significant penalties for submitting false information, including the possibility of fine and imprisonment for knowing violations.

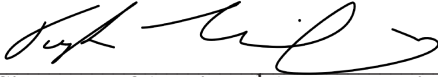

Signature of Applicant¹ (owner or prime contractor)

5/14/2026

Date Signed

Taylor Wilson

Printed Name¹

Director of Training Academy

Title

¹This application shall be signed as follows:

- For a corporation, by a responsible corporate officer.
- For a partnership, by a general partner.
- For a sole proprietorship, by the proprietor.

For a municipal, state or other public facility, by principal executive officer, mayor, or ranking elected official

Please submit the LCNOI form to:

Chief, Environmental Permits Division
MS Department of Environmental Quality, Office of Pollution Control
P.O. Box 2261
Jackson, Mississippi 39225

Electronically:

<https://www.mdeq.ms.gov/construction-stormwater/>

Revised 3/23/22

STORM WATER POLLUTION PREVENTION PLAN

MMC TRAINING CENTER

DFA/BOB, MADISON COUNTY, MS
CLOVERLEAF DR
CANTON, MS 39046

CONSULTING ENGINEER:

CHAD A. WAGES, P.E.
WAGES CIVIL
276 NISSAN PARKWAY
CANTON, MISSISSIPPI 39046

PHONE: (601) 391-4012
EMAIL: CHAD@WAGESCIVIL.COM

JUNE 4th, 2026

STORM WATER POLLUTION PREVENTION PLAN

MMC TRAINING CENTER

CANTON, MISSISSIPPI

Project Information

The MMC Training Center project is an industrial development spanning approximately 93 acres in Canton, Mississippi. Of the total site area, approximately 4.8 acres will be disturbed to accommodate the construction and associated infrastructure.

The facility will serve as a key training hub for MMC's operations, providing a dedicated environment for workforce development, skills training, and operational readiness. The training center is designed to support MMC's personnel with the resources and infrastructure necessary to maintain a highly capable and efficient workforce across their regional and national operations.

The development will include extensive civil engineering efforts, such as site grading, stormwater management, erosion and sediment control, and the installation of utility services to support the training center operations. Roadway improvements, internal access roads, and parking lot construction will be integral to optimizing vehicle and freight movement throughout the site.

Site Information

The project site is located at the intersections of Cloverleaf Dr, New Ragsdale Rd, and Nissan Dr in Canton, Mississippi. Currently undeveloped and grassed, the site features gentle slopes ranging from 0% to 8%. According to the USGS Web Soil Survey, approximately 30% of the site contains soils with hydric ratings, indicating areas with potential drainage challenges. Additionally, the site has poor soil conditions overall, necessitating careful management of existing materials to achieve a balanced earthwork plan. Onsite soils will be utilized where possible to meet the required volume of suitable fill material for grading and stabilization, minimizing the need for importing additional dirt.

Adjacent Property

The property is primarily bordered by Cloverleaf Dr, New Ragsdale Rd, and Nissan Dr, with the adjacent property to the east being a corporate office and maintenance facility of MMC Materials, Inc.

Soils

The soils are mapped in the soil survey as:

- 33.8% Ariel silt loam.
- 9.9% Gillsburg silt loam.
- 21.5% Grenada silt loam with 2 to 5 percent slopes and eroded.
- 31.7% Loring silt loam with 2 to 5 percent slopes and moderately eroded.
- 3.5% Oaklimer silt loam with 0 to 2 percent slopes and occasionally flooded.

Receiving Waters

Receiving Water	Basin	Waterbody ID	TMDL	Evaluated Cause
Bear Creek	Big Black River Basin	MS431BE	Yes	Nutrients and Organic Enrichment / Low DO / Biological Impairment due to Sediment

This project will prevent the discharge of sediment and pollutants to the Maximum Extent Practicable (MEP) through the implementation of structural and non-structural Best Management Practices (BMPs) described throughout this report, thereby minimizing impacts to receiving waters with established TMDLs.

The property has been fully delineated, and it has been determined that the proposed project will not require a permit from the U.S. Army Corps of Engineers (USACE), as no loss of wetlands or "waters of the United States" is expected to result from the planned activities.

Vegetative Controls

1. Temporary Vegetation

Disturbed areas where construction activities will be undisturbed for fourteen days or more will require temporary vegetative practices to be implemented within seven calendar days.

2. Permanent Stabilization

Permanent stabilization shall be initiated immediately upon final grading of disturbed areas. Final stabilization is achieved when at least 70% uniform perennial vegetative cover is established on all unpaved and disturbed areas. Silt fence and other temporary erosion control measures will be removed only after this level of vegetative cover has been established.

3. Vegetative Buffer Zones

Vegetative buffer zones must remain undisturbed between land-disturbing activities and perennial water bodies. A minimum buffer zone of 150 feet is recommended. If this distance cannot be maintained, additional protective measures shall be implemented.

Seeding Chart for the State of Mississippi

Volume 1 Erosion and Sediment Control Practices: Table PS-1

Species	Seeding Rates/Ac	Planting Time	Fertilization Rate/ Acre	Method of Establishment	Zone of Adaptability	Native/ Introduced
Common Bermuda	15 lbs. alone 10 lbs. mix	3/1 – 7/15 9/1 - 11/30	600 lbs. 13-13-13	Seed or Sod	All	Introduced *Potential for invasiveness
Bahia	40 lbs. alone 30 lbs. mix	3/1 – 7/15 9/1 - 11/30	600 lbs. 13-13-13	Seed	Central and South	Introduced
Fescue	40 lbs. alone 30 lbs. mix	9/1 - 11/30	600 lbs. 13-13-13	Seed	North and Central	Native
Saint Augustine	--	3/1 – 7/15	600 lbs. 13-13-13	Sod Only	All	Native
Centipede	4 lbs. alone 2.5 lbs. mix	3/1 – 7/15	600 lbs. 13-13-13	Seed or Sod	All	Introduced
Carpet Grass	15 lbs. alone 10 lbs. mix	3/1 – 7/15	600 lbs. 13-13-13	Seed or Sod	All	Native
Zoysia Grass	--	3/1 – 7/15	600 lbs. 13-13-13	Sod Only	All	Introduced
Creeping Red Fescue	30 lbs. alone 22.5 lbs. mix	9/1 - 11/30	600 lbs. 13-13-13	Seed	All	Native
Weeping Lovegrass	10 lbs. alone 5 lbs. mix		600 lbs. 13-13-13	Seed	All	Introduced
*Wheat	90 lbs. alone	9/1 - 11/30	600 lbs. 13-13-13	Seed	All	Native
*Ryegrass	30 lbs.	9/1 - 11/30	600 lbs. 13-13-13	Seed	All	Native
*White Clover	5 lbs.	9/1 - 11/30	400 lbs. 13-13-13	Seed	All	Introduced
*Crimson Clover	15 lbs.	9/1 - 11/30	400 lbs. 13-13-13	Seed	All	Introduced
Sericea Lespedeza	40 lbs.	3/1 – 7/15 9/1 - 11/30	400 lbs. 13-13-13	Seed	All	Introduced

*Hairy Vetch	30 lbs.	9/1 - 11/30	400 lbs. 13-13-13	Seed	All	Introduced
*Browntop Millet	15 lbs. alone 10 lbs. mix	4/1 - 8/30	600 lbs. 13-13-13	Seed	All	Introduced

* Note of Annuals: For permanent seeding, annuals can only be used in a mixture with perennials.

* Desired pH range for all species is 6.0 – 7.0.

Structural Controls

1. Limestone Construction Entrance

A temporary limestone construction entrance will be installed at all points where construction traffic enters or exits the site onto paved roads.

2. Silt Fence

Silt fencing will be installed around the perimeter of the construction area to prevent sediment transport from the site. Additional silt fencing will be strategically placed at the base of slopes and other critical locations as necessary, based on site conditions and ongoing construction activities.

3. Straw Wattles

Straw wattles shall be installed along the flowlines of existing and proposed drainage swales to reduce sediment transport along said swales.

4. Straw Bale Barriers

Straw bale barriers will be installed around proposed and existing inlets impacted by construction activities to prevent sediment entry. These barriers will be supplemented with silt fencing in areas where additional sediment control is required, ensuring effective protection of drainage systems.

5. Diversions

Temporary erosion control measures, such as erosion control blankets, will be installed across the site to stabilize cut and fill slopes with gradients of 3:1 or steeper. These measures will be implemented as necessary during and after final grading to prevent erosion and maintain slope integrity.

6. Sedimentation Basins

Sedimentation basins will be installed at drainage points along the boundaries of land-disturbing activities to capture stormwater runoff and allow sediment settlement before discharge. Diversion swales will direct runoff to these basins, which will use Faircloth skimmers for enhanced sediment removal. For drainage points affecting 10 or more disturbed acres, basins will provide 3,600 cubic feet of storage per acre drained, designed to handle a minimum 2-year, 24-hour storm event. If flocculants are used, basins will be located downstream and include baffles to improve sediment removal and reduce turbidity.

Non-storm Water Discharges

Allowed	Prohibited
Discharge from actual fire hydrant activities	Wastewater from washout of concrete
Fire hydrant flushing	Fuels, oils, or other pollutants used in vehicle and equipment operation and maintenance
Water used for dust control	
Potable water sources including uncontaminated water line flushing	Wastewater from washout and cleanout of stucco, paint, form release oils, curing compounds and other construction materials
Routine external building wash down that does not use detergents	
Pavement wash waters where spills or leaks of toxic or hazardous materials have not occurred and where detergents are not used	

Uncontaminated air conditioning or compressor condensate	Soaps or solvents used in vehicle and equipment washing
Uncontaminated ground water or spring water	
Foundation or footing drains where flows are not contaminated	Wastewater from sanitary facilities, including portable toilets
Uncontaminated excavation dewatering	
Landscape irrigation	
Water used to wash vehicles, wheel wash water and other wash waters where detergents are not used.	

Housekeeping Practices

The owner or contractor is responsible for maintaining effective housekeeping practices throughout the duration of the project until all construction activities are concluded. These practices must be implemented in a manner that prevents pollutants—such as oils, grease, paints, gasoline, solvents, litter, debris, and sanitary waste—from entering the stormwater system at any point during construction. Effective housekeeping includes, but is not limited to, measures such as:

1. Designated areas for on-site equipment repairs and maintenance should be established as soon as construction activities begin. These areas must be clearly identified. Any pollutants, such as oils or chemicals, that are spilled or released onto the ground must be promptly cleaned up and properly disposed of to prevent contamination of the site.
2. The contractor is responsible for storing materials, including chemicals and other toxic substances, in designated protected areas when not in use or during rainfall. These materials must be kept in their original containers, and any spills must be cleaned up and disposed of immediately. Additionally, building supplies should be stored in designated laydown areas to ensure organization and reduce environmental risks.
3. Designated areas for concrete chute wash-off will be established as soon as concrete construction activities commence. These areas should be identified clearly on-site, ensuring that runoff from concrete washing is contained and managed properly to prevent contamination.
4. Waste receptacles shall be placed at convenient locations throughout the site. These include separate bins for general waste, construction debris, and recyclables. Waste shall be collected regularly to maintain site cleanliness and minimize the risk of environmental contamination.
5. Adequately maintained sanitary facilities shall be provided for all personnel working on-site. These facilities shall be regularly serviced and stocked with necessary supplies to ensure proper hygiene and waste disposal.
6. Spill prevention and response procedures shall be implemented for all hazardous materials stored on-site. Spill kits and absorbent materials shall be kept in easily accessible locations. In the event of a spill or leak, immediate action shall be taken to contain and clean up the material, ensuring minimal environmental impact.
7. Measures shall be put in place to minimize the exposure of construction materials, building products, waste, and landscaping materials to the elements. These materials shall be stored in designated areas, properly covered to prevent wind or water dispersion. Regular inspections shall ensure that all materials are stored securely and are not subject to weather-related exposure.

8. Remove sediment tracked from the site onto paved roads, sidewalks, or other paved areas outside the site no later than the end of the next workday. Use sweeping, shoveling, vacuuming, or other equally effective methods to clear the sediment.

Maintenance Plan

The owner or contractor is responsible for onsite maintenance to ensure that all vegetation, erosion, and sediment controls are regularly inspected, maintained, and repaired to prevent environmental degradation and comply with project requirements. Inspections will be performed weekly, ensuring a minimum of four inspections per month. In accordance with Act 5, T-16 of the Mississippi Construction General Permit, all erosion and sediment controls, as well as all outfalls and discharge points, shall also be inspected within 24 hours of any rainfall event that produces a discharge from the site. Regular documentation and follow-up will help identify issues early and ensure that protective measures remain effective throughout the project's duration.

1. **Vegetation Maintenance Procedures**

Vegetation shall be monitored and maintained regularly to prevent erosion and ensure soil stabilization. This includes:

- Ensuring proper germination and growth of vegetative cover on disturbed areas.
- Re-seeding areas as necessary to restore coverage, particularly after heavy rainfall or erosion events.
- Applying mulch or hydroseeding, as needed, to protect soil and promote growth.

2. **Erosion and Sediment Control Maintenance**

Erosion and sediment control measures such as silt fences, sediment basins, diversion swales, and straw bale barriers shall be maintained to ensure they function effectively:

- Inspecting and repairing silt fences and barriers to ensure they remain intact and properly installed.
- Regularly inspect and clear sediment from diversion swales and drainage ditches, checking for obstructions or damage.
- Ensuring erosion control blankets or mats are properly placed and maintained on slopes and exposed areas.

3. **Documentation and Reporting**

Detailed records will be kept for each inspection, including:

- Daily rain gauge log recorded weekly.
- Date and time of inspection.
- Areas inspected and specific conditions noted.
- Actions taken to address any issues.

- Any follow-up actions required for ongoing maintenance.

Reports will be submitted to the project manager and/or contractor and retained for project records to demonstrate compliance with environmental regulations.

Implementation Sequence

1. **Mark Limits of Disturbance:** Clearly stake or flag the limits of disturbance, ensuring they remain visible throughout the construction process.
2. **Install Perimeter Sediment Controls:** Install sediment control BMPs around the planned construction area and down-gradient to manage runoff. Start with the minimum area necessary to set up these perimeter controls, understanding that work may occur in phases.
3. **Set Up Construction Exit:** Install the stabilized construction exit and, if applicable, set up the project job trailer.
4. **Install Additional BMPs and Begin Grading:** Install remaining BMPs along runoff flow paths and begin grading operations on-site.
5. **Roadway and Building Pad Construction:** Begin constructing roadways and building pads. Create temporary impoundments to function as sediment basins until permanent spillways are installed. Stabilize disturbed areas immediately after grading activities, particularly those inactive for 14 days or more, implementing stabilization practices within 7 days.
6. **Stabilize Final Graded Areas:** Immediately stabilize areas that will be permanently vegetated once they reach final grade.
7. **Install Storm Sewers and Utilities:** Begin installation of storm sewers and utilities as part of the site development.
8. **Erosion Control at Storm Outfalls:** Install riprap or other erosion control BMPs at stormwater outfall locations as each outfall structure is completed.
9. **Install Inlet Protection:** Install inlet protection devices at each storm sewer inlet during construction.
10. **Prepare Roadways for Paving:** Complete the necessary preparation for roadway paving.
11. **Pave Roadways:** Lay down the binder course of hot-mixed asphalt or as specified by the engineer.
12. **Final Grading and Permanent Stabilization:** Complete final grading and apply permanent stabilization measures across the site, including ponds and disturbed areas.
13. **Obtain Concurrence from Owner's Representative:** Verify that the site has been fully stabilized and that construction activities are complete. Upon confirmation:
 - a. Remove all temporary erosion and sediment control BMPs

b. Stabilize areas disturbed during the removal of these BMPs.

14. **Final Inspections and Permit Termination:** Continue inspections and provide reports until the owner's representative confirms the site is ready to terminate stormwater permit coverage.

Staff Training Requirements

Before construction activities begin, each operator or group of operators must establish a "stormwater team" responsible for ensuring compliance with the permit's requirements. The team should include personnel who understand their specific roles, including:

1. **Design, Installation, and Maintenance of Stormwater Controls:** Personnel responsible for the design, installation, maintenance, and/or repair of stormwater controls, including pollution prevention measures.
2. **Chemical Application and Storage:** Personnel in charge of applying and storing treatment chemicals.
3. **Inspections:** Personnel tasked with conducting inspections in compliance with ACT6, S-5.
4. **Corrective Actions:** Personnel responsible for implementing corrective actions as specified in ACT6, S-2.

The permittee must ensure that all site activities comply with the permit requirements. While formal training for subcontractors or outside service providers is not required, the permittee must ensure these personnel understand any relevant permit requirements related to their work. At a minimum, members of the stormwater team must be trained on:

1. **Deadlines:** The timelines for the installation, maintenance, removal of stormwater controls, and stabilization.
2. **Location and Maintenance:** The location of stormwater controls on-site and how to maintain them.
3. **Pollution Prevention:** Procedures for adhering to pollution prevention requirements.
4. **Inspections and Corrective Actions:** The process for conducting inspections, documenting findings, and taking corrective actions when necessary.

Each team member must have ready access to a copy of relevant portions of the permit, the most current SWPPP, and other necessary documents.

Staff Training Requirements

Training conducted to fulfill the requirements of this ACT must be properly documented. Training records should include the employee's name, the date of training, a brief description of the training content, and the employee's signature to confirm receipt of the training. Documentation of staff training related to this permit may be recorded using the Employee Training Log available on the MDEQ website at www.mdeq.ms.gov/construction-stormwater/. Alternatively, the permittee may use a different form, provided it

captures all the required information. Training records must be kept on-site with the SWPPP and be available for inspection by MDEQ personnel upon request.

Post Construction Plan

Upon the completion of the construction phase, the post construction storm water management plan will be implemented by the owners. The post construction storm water management plan will include the conversion of the sediment basin to regional detention dry basin. The basin has been designed based upon the MDEQ Specific Design Criteria for dry detention basin. Maintenance of the basin will be the responsibility of the owner.

Hydric Rating by Map Unit—Madison County, Mississippi
(b)

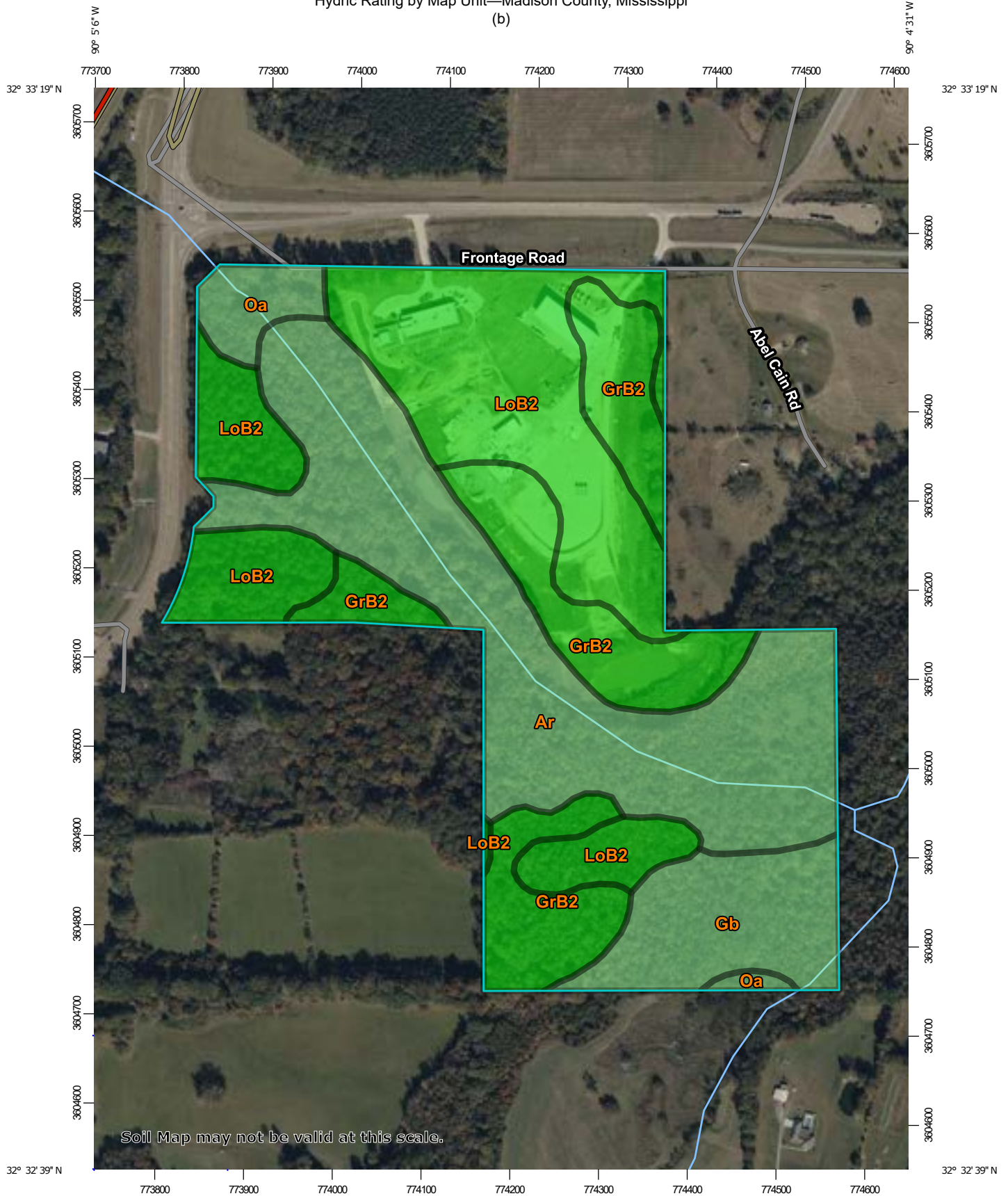

Soil Map may not be valid at this scale.

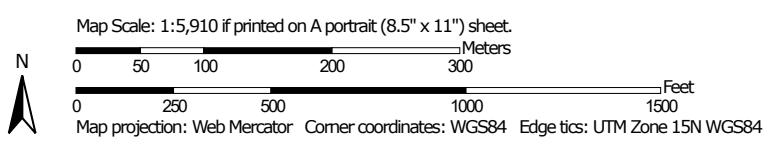







MAP LEGEND

Area of Interest (AOI)







 Area of Interest (AOI)

Soils







Soil Rating Polygons

 Hydric (100%)
 Hydric (66 to 99%)
 Hydric (33 to 65%)
 Hydric (1 to 32%)
 Not Hydric (0%)
 Not rated or not available

Soil Rating Lines

 Hydric (100%)
 Hydric (66 to 99%)
 Hydric (33 to 65%)
 Hydric (1 to 32%)
 Not Hydric (0%)
 Not rated or not available





Soil Rating Points

 Hydric (100%)
 Hydric (66 to 99%)
 Hydric (33 to 65%)
 Hydric (1 to 32%)
 Not Hydric (0%)
 Not rated or not available

Water Features

 Streams and Canals

Transportation

 Rails
 Interstate Highways
 US Routes
 Major Roads
 Local Roads

Background

 Aerial Photography

MAP INFORMATION

The soil surveys that comprise your AOI were mapped at 1:20,000.

Warning: Soil Map may not be valid at this scale.

Enlargement of maps beyond the scale of mapping can cause misunderstanding of the detail of mapping and accuracy of soil line placement. The maps do not show the small areas of contrasting soils that could have been shown at a more detailed scale.

Please rely on the bar scale on each map sheet for map measurements.

Source of Map: Natural Resources Conservation Service
 Web Soil Survey URL:
 Coordinate System: Web Mercator (EPSG:3857)

Maps from the Web Soil Survey are based on the Web Mercator projection, which preserves direction and shape but distorts distance and area. A projection that preserves area, such as the Albers equal-area conic projection, should be used if more accurate calculations of distance or area are required.

This product is generated from the USDA-NRCS certified data as of the version date(s) listed below.

Soil Survey Area: Madison County, Mississippi
 Survey Area Data: Version 20, Sep 8, 2025

Soil map units are labeled (as space allows) for map scales 1:50,000 or larger.

Date(s) aerial images were photographed: Nov 8, 2021—Nov 29, 2021

The orthophoto or other base map on which the soil lines were compiled and digitized probably differs from the background imagery displayed on these maps. As a result, some minor shifting of map unit boundaries may be evident.



Hydric Rating by Map Unit

Map unit symbol	Map unit name	Rating	Acres in AOI	Percent of AOI
Ar	Ariel silt loam	10	31.4	33.8%
Gb	Gillsburg silt loam	10	9.2	9.9%
GrB2	Grenada silt loam, 2 to 5 percent slopes, eroded	0	19.6	21.1%
LoB2	Loring silt loam, 2 to 5 percent slopes, moderately eroded, central	0	29.4	31.7%
Oa	Oaklimeter silt loam, 0 to 2 percent slopes, occasionally flooded, north	2	3.2	3.5%
Totals for Area of Interest			92.9	100.0%



Description

This rating indicates the percentage of map units that meets the criteria for hydric soils. Map units are composed of one or more map unit components or soil types, each of which is rated as hydric soil or not hydric. Map units that are made up dominantly of hydric soils may have small areas of minor nonhydric components in the higher positions on the landform, and map units that are made up dominantly of nonhydric soils may have small areas of minor hydric components in the lower positions on the landform. Each map unit is rated based on its respective components and the percentage of each component within the map unit.

The thematic map is color coded based on the composition of hydric components. The five color classes are separated as 100 percent hydric components, 66 to 99 percent hydric components, 33 to 65 percent hydric components, 1 to 32 percent hydric components, and less than one percent hydric components.

In Web Soil Survey, the Summary by Map Unit table that is displayed below the map pane contains a column named 'Rating'. In this column the percentage of each map unit that is classified as hydric is displayed.

Hydric soils are defined by the National Technical Committee for Hydric Soils (NTCHS) as soils that formed under conditions of saturation, flooding, or ponding long enough during the growing season to develop anaerobic conditions in the upper part (Federal Register, 1994). Under natural conditions, these soils are either saturated or inundated long enough during the growing season to support the growth and reproduction of hydrophytic vegetation.

The NTCHS definition identifies general soil properties that are associated with wetness. In order to determine whether a specific soil is a hydric soil or nonhydric soil, however, more specific information, such as information about the depth and duration of the water table, is needed. Thus, criteria that identify those estimated soil properties unique to hydric soils have been established (Federal Register, 2002). These criteria are used to identify map unit components that normally are associated with wetlands. The criteria used are selected estimated soil properties that are described in "Soil Taxonomy" (Soil Survey Staff, 1999) and "Keys to Soil Taxonomy" (Soil Survey Staff, 2006) and in the "Soil Survey Manual" (Soil Survey Division Staff, 1993).

If soils are wet enough for a long enough period of time to be considered hydric, they should exhibit certain properties that can be easily observed in the field. These visible properties are indicators of hydric soils. The indicators used to make onsite determinations of hydric soils are specified in "Field Indicators of Hydric Soils in the United States" (Hurt and Vasilas, 2006).

References:

Federal Register. July 13, 1994. Changes in hydric soils of the United States.

Federal Register. September 18, 2002. Hydric soils of the United States.



Hurt, G.W., and L.M. Vasilas, editors. Version 6.0, 2006. Field indicators of hydric soils in the United States.

Soil Survey Division Staff. 1993. Soil survey manual. Soil Conservation Service. U.S. Department of Agriculture Handbook 18.

Soil Survey Staff. 1999. Soil taxonomy: A basic system of soil classification for making and interpreting soil surveys. 2nd edition. Natural Resources Conservation Service. U.S. Department of Agriculture Handbook 436.

Soil Survey Staff. 2006. Keys to soil taxonomy. 10th edition. U.S. Department of Agriculture, Natural Resources Conservation Service.

Rating Options

Aggregation Method: Percent Present

Component Percent Cutoff: None Specified

Tie-break Rule: Lower





U.S. DEPARTMENT OF THE INTERIOR
U.S. GEOLOGICAL SURVEY



7.5-MINUTE TOPO QUADRANGLE
MISSOURI - EASTON EXTENT
7.5-MINUTE TOPO

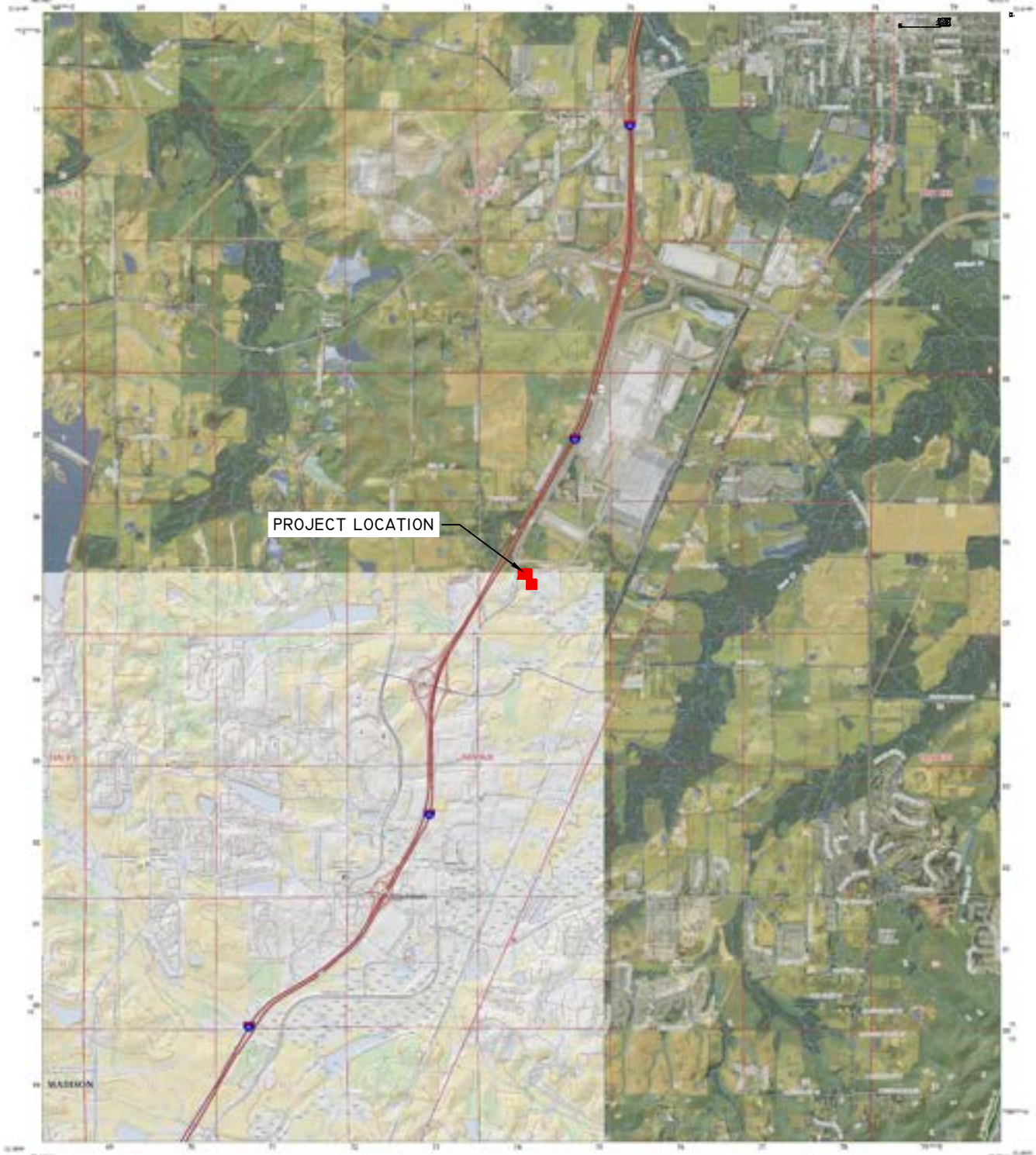

Produced by the United States Geological Survey
 Topographic Data File (TDF) - 2011
 The data in this file were derived from the National
 Map Accuracy Act of 1966. The data were derived from
 the National Map Accuracy Act of 1966. The data were
 derived from the National Map Accuracy Act of 1966.
 The data in this file were derived from the National
 Map Accuracy Act of 1966. The data were derived from
 the National Map Accuracy Act of 1966. The data were
 derived from the National Map Accuracy Act of 1966.

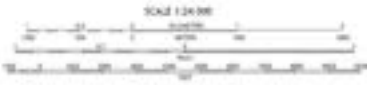

Map Legend
 Road Centerline
 Road Right-of-Way
 Road Left-of-Way
 Project Location
 Contour Interval
 Spot Elevation

7.5-MINUTE TOPO, MI
 2011

**PRELIMINARY CONSTRUCTION PLANS
MMC TRAINING CENTER
WAGES CIVIL PROJECT NUMBER 121-001-25**

JUNE 2026

OWNER INFORMATION

COMPANY: MMC MATERIALS, INC.
OWNER NAME: RODNEY GROGAN
EMAIL: RGROGAN@MMCMATERIALS.COM
PHONE: (601) 898-4000

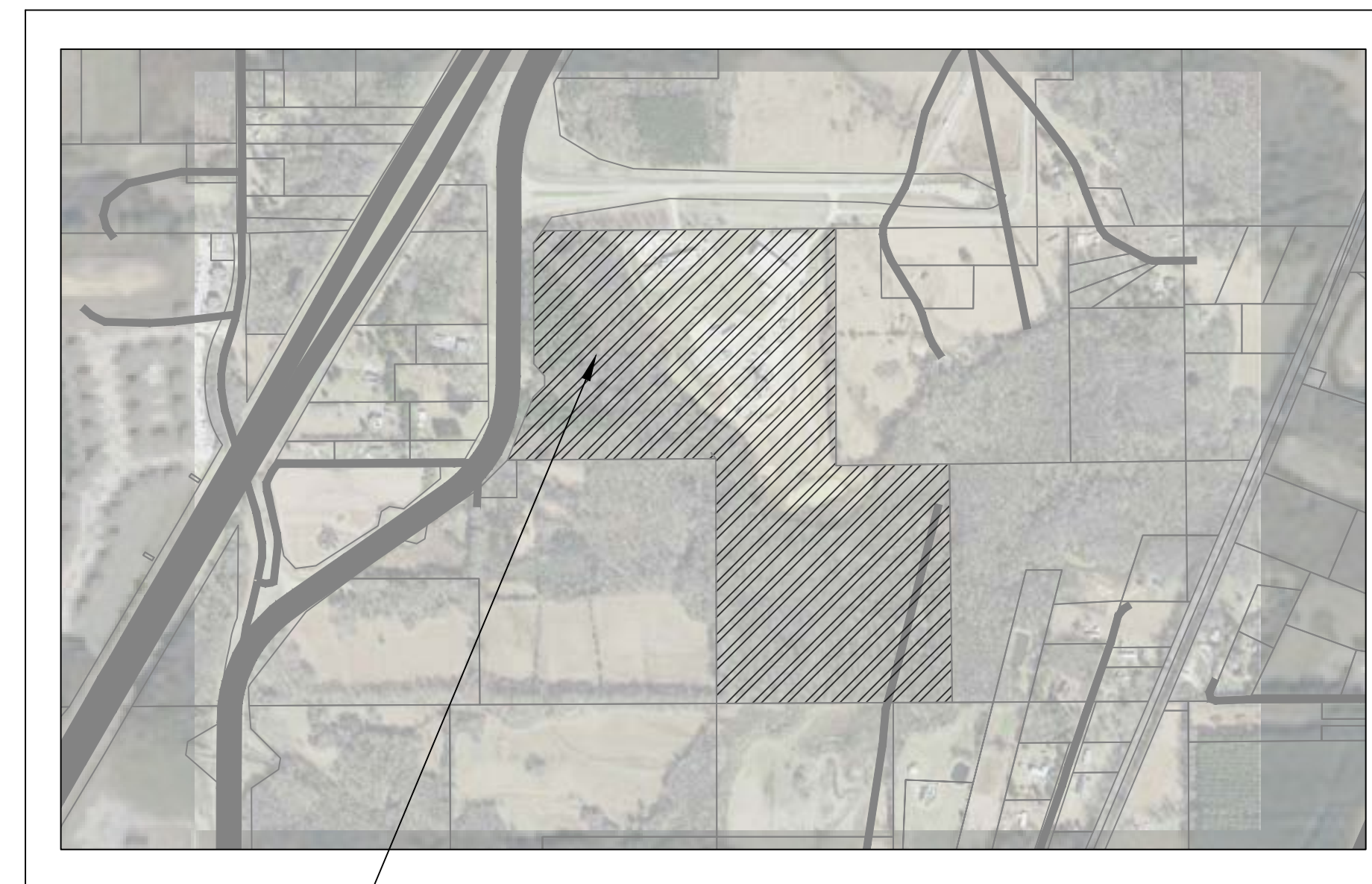

PROJECT LOCATION

VICINITY MAP

SCALE: 1"=800'

INDEX:

SHEET NO.	DESCRIPTION
C100	COVER
C101	GENERAL NOTES
C102	EXISTING CONDITIONS & AERIAL
C103	EROSION CONTROL PLAN
C104	SITE PLAN
C105	GRADING PLAN
C201	DETAILS
C202	DETAILS

PREPARED BY

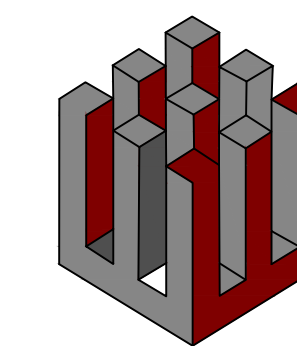

WAGES CIVIL, LLC
ENGINEERING • CONSULTING • ECONOMIC DEVELOPMENT

276 NISSAN PARKWAY (BUILDING B SUITE 300)
CANTON, MISSISSIPPI 39046
PHONE: 601-259-3662
EMAIL: CHAD@WAGESCIVIL.COM

PRELIMINARY Date: XX/XX/XXXX

Chad Wages
Mississippi License No. 12971

UTILITY & EMERGENCY CONTACT INFORMATION

WATER, SEWER, GAS & ECLECTIC

CANTON MUNICIPAL UTILITIES
 CUSTOMER SERVICE
 127 WEST PEACE STREET
 CANTON, MISSISSIPPI 39046
 601-859-2474

PLANNING & DEVELOPMENT

CANTON BUILDING & DEVELOPMENT
 226 EAST PEACE STREET
 CANTON, MS 39046
 601-859-4331
 WBURWELL@CANTONMS.GOV

FIRE DEPARTMENT

CANTON FIRE DEPARTMENT
 3393 N. LIBERTY STREET
 CANTON, MS 39046
 601-859-3112
 CFDCHIEF@CANTONMS.GOV

POLICE DEPARTMENT

CANTON POLICE DEPARTMENT
 200 PARK DRIVE
 CANTON, MS 39046
 601-859-2121
 CPDCHIEF@CANTONMS.GOV

MISSISSIPPI 811

MISSISSIPPI 811, INC
 200 COUNTRY PLACE PARKWAY
 PEARL, MISSISSIPPI 39208

LOCATE REQUEST: (800)-227-6477 OR 811



GENERAL NOTES & CONSTRUCTION SPECIFICATIONS

GENERAL NOTES:

- IT SHALL BE THE RESPONSIBILITY OF THE CONTRACTOR TO PROTECT EXISTING STRUCTURES AND SITE IMPROVEMENTS SUCH AS PIPES, INLETS, APRONS, PAVEMENTS, BRIDGES, ETC. FROM DAMAGE WHICH MIGHT OCCUR DURING CONSTRUCTION, EXTREME CARE SHOULD BE EXERCISED IN UNDERCUT AREAS AND THE UNDERCUT DEPTH MAY BE ADJUSTED AT CROSS DRAINS, AS DIRECTED BY THE ENGINEER. THE CONTRACTOR SHALL REPLACE OR REPAIR, AS DIRECTED BY THE ENGINEER, ANY STRUCTURES DAMAGED DURING THE LIFE OF THE CONTRACT. NO PAYMENT WILL BE MADE FOR REPLACEMENT OR REPAIR OF DAMAGED ITEMS.
- VOIDS CREATED BY THE REMOVAL OF POSTS, CONCRETE ANCHORS, FOOTINGS, ETC. SHALL BE BACK FILLED AND TAMPED IN ACCORDANCE WITH SECTION 203 OF THE MISSISSIPPI DEPARTMENT OF TRANSPORTATION STANDARD SPECIFICATIONS FOR ROAD AND BRIDGES CONSTRUCTION.
- EXISTING UNDERGROUND UTILITY LINES ARE SHOWN ON THE DRAWINGS BASED UPON THE BEST INFORMATION AVAILABLE TO THE ENGINEER. THE ENGINEER CANNOT AND DOES NOT WARRANT THAT THIS INFORMATION IS COMPLETE OR ACCURATE. THE CONTRACTOR MUST COORDINATE DIRECTLY WITH THE INVOLVED UTILITY OWNERS TO HAVE UNDERGROUND UTILITY LINES FIELD LOCATED IN ADVANCE OF CONSTRUCTION. -- MS ONE CALL 811 OR 800-227-6477
- CONTRACTOR SHALL EXERCISE EXTREME CAUTION DURING EXCAVATION AND TRENCHING OPERATIONS. IT SHALL BE THE CONTRACTOR'S RESPONSIBILITY TO PLACE WHAT BRACING, SHORING OR GROUND SUPPORT SYSTEM THAT IS DEEMED NECESSARY TO PREVENT A FAILURE AND PROTECT THE PERSONS WORKING NEAR THE EXCAVATION, THE PUBLIC THAT MAY BE ABOVE THE EXCAVATION, OR ANY STRUCTURE ADJACENT TO THE EXCAVATION. ALL COSTS FOR ANY PROTECTIVE MEASURES, INCLUDING THE MATERIALS AND LABOR FOR DESIGNING, DRAFTING AND CONSTRUCTING THE FACILITY, SHALL BE INCLUDED IN THE PRICE BID FOR CONTRACT ITEMS.
- UTILITY LINES OR SERVICE LINES ENCOUNTERED DURING CONSTRUCTION, WHETHER SHOWN ON THE DRAWINGS OR NOT, SHALL BE PROTECTED BY THE CONTRACTOR AND REPAIRS NECESSARY DUE TO DAMAGE TO SOME BY THE CONTRACTOR SHALL BE AT NO ADDITIONAL COST TO THE OWNER.
- EXISTING PAVEMENTS OF PUBLIC ROADWAYS SHALL BE PATCHED IN ACCORDANCE TO CANTON COUNTY STANDARDS WHEREVER UTILITY INSTALLATION REQUIRES REMOVAL OF THE EXISTING PAVEMENT. COORDINATE PAVEMENT TRENCHING LOCATIONS WITH ENGINEER.
- PROVIDE A SMOOTH TRANSITION BETWEEN EXISTING PAVEMENT AND NEW PAVEMENT. SLIGHT FIELD ADJUSTMENT OF FINAL GRADES MAY BE NECESSARY.
- THE CONTRACTOR SHALL PAVE IN THE DIRECTION OF TRAFFIC.
- CONTRACTOR RESPONSIBLE FOR EROSION CONTROL. CONTRACTOR SHALL SEED, FERTILIZE, AND MULCH AREAS WHERE EXISTING VEGETATION HAS BEEN DISTURBED AS A RESULT OF CONSTRUCTION ACTIVITIES.
- CONTRACTOR RESPONSIBLE FOR LAYOUT OF SITE IMPROVEMENTS AND CONSTRUCTION STAKING. CONTRACTOR RESPONSIBLE FOR ESTABLISHING SURVEY CONTROL. COST OF LAYOUT & CONSTRUCTION STAKING SHALL BE AN ABSORBED ITEM OF WORK.
- CONTRACTOR RESPONSIBLE FOR TRAFFIC CONTROL. THE CONTRACTOR SHALL MAINTAIN THROUGH TRAFFIC ALONG EXISTING ROADS FOR THE LENGTH OF THE CONTRACT PERIOD. ALL TRAFFIC CONTROL SHALL BE IN ACCORDANCE WITH THE REQUIREMENTS OF THE MANUAL OF UNIFORM TRAFFIC CONTROL DEVICES, LATEST EDITION(S).
- CONTRACTOR SHALL PREVENT TRACKING OF MUD, SEDIMENTS, VEGETATIVE MATERIALS, AND DEBRIS ONTO PUBLIC ROADWAYS. CONTRACTOR SHALL REMOVE MUD, SEDIMENTS, VEGETATIVE MATERIALS, AND DEBRIS FROM PUBLIC ROADWAYS AT NO ADDITIONAL COST TO OWNER.
- SPECIFICATIONS: MISSISSIPPI STANDARD SPECIFICATIONS FOR STATE AID ROAD AND BRIDGE CONSTRUCTION, 2024 EDITION.

DEMOLITION:

- THE CONTRACTOR SHALL CONFIRM THE DEMOLITION LIMITS WITH THE PROJECT REPRESENTATIVE PRIOR TO BEGINNING WORK.
- THE CONTRACTOR SHALL COORDINATE DEMOLITION PHASING WITH THE PROJECT REPRESENTATIVE BEFORE CONSTRUCTION BEGINS. ANY DISRUPTIONS TO EXISTING UTILITY SERVICES OR TRAFFIC PATTERNS SHALL BE MINIMIZED AND MAY ONLY OCCUR WITH PRIOR APPROVAL FROM THE ENGINEER AND THE COUNTY ENGINEER.
- ALL VOIDS OR CAVITIES CREATED BY STRUCTURE REMOVAL SHALL BE PROPERLY BACKFILLED AND COMPACTED TO THE SATISFACTION OF THE ENGINEER.
- THE CONTRACTOR SHALL IMPLEMENT DUST CONTROL MEASURES, INCLUDING WATER SPRINKLING OR OTHER APPROVED METHODS, TO LIMIT DUST AND DEBRIS GENERATED BY DEMOLITION ACTIVITIES.
- THE CONTRACTOR SHALL PROTECT ALL SURVEY CONTROL POINTS THROUGHOUT DEMOLITION OPERATIONS. ANY DISTURBED OR DAMAGED CONTROL POINTS SHALL BE REPLACED AT THE CONTRACTOR'S EXPENSE.

EROSION CONTROL:

- DURING CONSTRUCTION, EROSION CONTROL PRACTICES SHALL BE INSTALLED AND MAINTAINED TO MINIMIZE SOIL LOSS AND PREVENT SEDIMENT FROM LEAVING THE CONSTRUCTION SITE.
- ALL EROSION AND SEDIMENT CONTROL MEASURES SHALL BE PROPERLY SELECTED, INSTALLED, AND MAINTAINED IN ACCORDANCE WITH MANUFACTURER RECOMMENDATIONS AND ACCEPTED ENGINEERING PRACTICES.
- CONTROLS MUST SLOW STORMWATER RUNOFF ENOUGH TO PREVENT RILL AND GULLY FORMATION. IF INSPECTIONS SHOW A CONTROL IS NOT FUNCTIONING PROPERLY, THE CONTRACTOR SHALL REPAIR, REPLACE, OR MODIFY IT AS NEEDED.
- SEEDING SHOULD NOT BE DELAYED INTO PERIODS OF DROUGHT OR WINTER UNLESS PROTECTIVE COVER IS PROVIDED.
- ANY SEDIMENT THAT LEAVES THE CONSTRUCTION SITE AND ACCUMULATES OFFSITE (SUCH AS IN STREETS OR DRAINAGE WAYS) SHALL BE PROMPTLY REMOVED TO AVOID IMPACTS TO STORM SEWERS, STREAMS, OR PUBLIC SAFETY. NO STREAM REMEDIATION WORK SHALL BEGIN WITHOUT PRIOR APPROVAL FROM MDEQ. SEDIMENT REMOVAL FROM PRIVATE PROPERTY MUST BE COORDINATED DIRECTLY WITH THE LANDOWNER.
- SEDIMENT SHALL BE REMOVED FROM TRAPS, FENCES, PONDS, AND OTHER MEASURES AS NEEDED AND ALWAYS WHEN STORAGE CAPACITY HAS BEEN REDUCED BY 50%.
- CONSTRUCTION DEBRIS, LITTER, AND CHEMICALS MUST BE COLLECTED AND PROPERLY DISPOSED OF BEFORE STORM EVENTS OR BEFORE WIND OR RUNOFF CAN CARRY THEM OFF SITE. MATERIALS USED FOR EROSION AND SEDIMENT CONTROL MUST ALSO BE DISPOSED OF PROPERLY ONCE NO LONGER NEEDED.
- OFFSITE MATERIAL STORAGE AREAS (INCLUDING OVERBURDEN AND SOIL STOCKPILES) ARE CONSIDERED PART OF THE PROJECT AND MUST COMPLY WITH THE SWPPP.
- EXISTING VEGETATION SHALL NOT BE REMOVED MORE THAN 10 DAYS PRIOR TO GRADING UNLESS TEMPORARY COVER SUCH AS SEEDING OR MULCH IS PROVIDED.
- CLEARING AND GRUBBING SHALL BE LIMITED TO THE MINIMUM AREA NECESSARY FOR GRADING AND EQUIPMENT ACCESS.
- CONSTRUCTION ACTIVITIES SHALL BE PHASED AND SEQUENCED TO MINIMIZE THE AMOUNT OF TIME SOIL IS LEFT EXPOSED.
- EROSION PREVENTION AND SEDIMENT CONTROL MEASURES MUST BE IN PLACE AND FUNCTIONAL BEFORE EARTHWORK BEGINS AND MAINTAINED THROUGHOUT CONSTRUCTION. TEMPORARY MEASURES MAY BE REMOVED DURING WORK BUT SHALL BE REINSTALLED AT THE END OF EACH WORKDAY.

LEGEND

	PROPERTY LINE
	RIGHT-OF-WAY
	EASEMENT
	FENCE
	ROAD CENTERLINE
	RETAINING WALL
	HEAVY DUTY SILT FENCE
	LIMITS OF DISTURBANCE
	SANITARY SEWER
	WATER LINE
	FORCEMAIN
	GAS LINE
	STORM PIPE
	OVERHEAD ELECTRICAL
	UNDERGROUND ELECTRICAL
	FIBER OPTICS
	GAS LINE
	FIRE HYDRANT

GRADING:

- THE CONTRACTOR SHALL TAKE NECESSARY MEASURES TO ACHIEVE PERMANENT SOIL STABILIZATION.
- VERIFY EXISTING GRADES AND DIMENSIONS IN THE FIELD BEFORE BEGINNING WORK. REPORT ANY DISCREPANCIES TO THE ENGINEER.
- ADJUST CASTINGS OF NEW AND EXISTING STRUCTURES TO MATCH PROPOSED FINISHED GRADES.
- PROPOSED CONTOUR LINES AND SPOT ELEVATIONS REPRESENT THE INTENDED GRADING DESIGN. CONTACT THE ENGINEER IF DISCREPANCIES OR CONFLICTS IN GRADING ARE ENCOUNTERED.
- ALL EARTHWORK, INCLUDING SUBGRADE PREPARATION AND FILL PLACEMENT, SHALL BE MONITORED AND APPROVED BY A GEOTECHNICAL ENGINEER OR THEIR REPRESENTATIVE.
- THE CONTRACTOR IS RESPONSIBLE FOR VERIFYING SITE SUBSURFACE CONDITIONS. NO GUARANTEE OF SOIL CONDITIONS IS IMPLIED BY THE GRADING PLAN.
- COMPACTION OF FILL AROUND AND ABOVE PIPES, STRUCTURES, AND OTHER BURIED FEATURES SHALL BE SUFFICIENT TO PREVENT SETTLEMENT. ANY SETTLEMENT OCCURRING DURING THE WARRANTY PERIOD SHALL BE REPAIRED BY THE CONTRACTOR AT NO ADDITIONAL COST.
- DISTURBANCE OF EXISTING VEGETATION SHALL BE LIMITED TO AREAS NECESSARY FOR GRADING AND CONSTRUCTION.
- STRIP AND STOCKPILE TOPSOIL FROM CUT AND FILL AREAS. REPLACE A MINIMUM OF 6 INCHES OF TOPSOIL ON DISTURBED AREAS UPON COMPLETION OF GRADING. PROVIDE ADDITIONAL TOPSOIL IF REQUIRED.
- DRAINAGE STRUCTURES SHALL BE CONSTRUCTED TO MATCH ELEVATIONS SHOWN ON THE PLANS. GRATES SHALL FOLLOW ROADWAY SLOPE FOR PROPER DRAINAGE.
- POSITIVE DRAINAGE SHALL BE MAINTAINED AT ALL TIMES DURING AND AFTER CONSTRUCTION. SOFT OR UNSUITABLE SOILS SHALL BE UNDERCUT AND REPLACED WITH APPROVED MATERIAL.
- ALL FILL MATERIALS SHALL BE APPROVED BY THE GEOTECHNICAL ENGINEER AND PLACED IN CONTROLLED LIFTS WITH PROPER COMPACTION.
- SEDIMENT COLLECTED FROM EROSION AND SEDIMENT CONTROL MEASURES SHALL BE DISPOSED OF AT AN APPROVED LOCATION AND MANAGED TO PREVENT ADDITIONAL RUNOFF OR CONTAMINATION.
- STOCKPILED SOILS AND MATERIALS SHALL BE STABILIZED TO PREVENT SEDIMENT FROM LEAVING THE SITE.
- THE CONTRACTOR SHALL BE RESPONSIBLE FOR PROPERLY DISPOSING OF EXCESS MATERIALS AND IMPORTING SUITABLE FILL, AS REQUIRED, AT NO ADDITIONAL COST TO THE OWNER.

PRELIMINARY CONSTRUCTION PLANS

MMC TRAINING CENTER

P:\016/4/2026 2:49 PM

SAVE5/7/2026 3:10 PM

C:\Users\ZoeByrd\OneDrive\Files\MMC Training Center\Project Files\Civil\CAD\SHEET_2-GN.dwg

C:\Users\ZoeByrd\OneDrive\Files\MMC Training Center\Project Files\Civil\CAD\SHEET_2-GN.dwg

NOTICE TO DRAWING HOLDER
 WAGES CIVIL, LLC, HERINAFTER REFERRED TO AS ENGINEER, HAS PREPARED & FURNISHED THIS DRAWING TO THE OWNER FOR USE ON THIS PROJECT ONLY. THIS DRAWING SHOULD NOT BE USED ON EXTENSIONS OF THIS PROJECT OR ON ANY OTHER PROJECT. ANY REUSE OF THIS DRAWING WITHOUT WRITTEN VERIFICATION OR ADAPTATION BY THE ENGINEER SHALL BE AT THE REUSER'S SOLE RISK AND THE REUSER SHALL INDEMNIFY & HOLD HARMLESS THE ENGINEER FROM ALL CLAIMS, DAMAGES, LOSSES & EXPENSES INCLUDING ATTORNEY'S FEES ARISING OUT OF OR RESULTING THEREFROM.

REVISIONS				DRAWING INFORMATION	
NO.	DATE	BY	DESCRIPTION	W-C PROJECT NO.:	SCALE:
				121-001-25	AS NOTED
					SURVEYED BY: N/A
					DSGN: JW DATE: 5.8.2026
					DRWN: JW DATE: 5.8.2026
					CHKD: CW DATE: 5.8.2026

MMC TRAINING CENTER
 MADISON COUNTY, MISSISSIPPI



GENERAL NOTES

PROJECT NUMBER: **121-001-25**
 DRAWING NUMBER: **C101**

STAMP

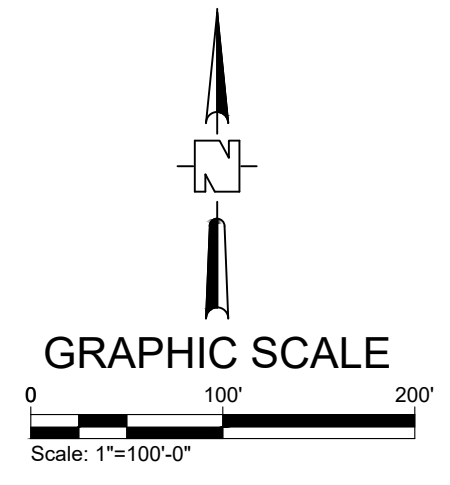

C:\Users\zooibryd\OneDrive\Documents\Wages Civil\WCT121-001-25 MMC Training Center\Project Files\Civil\CAD\SHEET_3-PRE_DEV.dwg
 SWE6/4/2026 2:49 PM
 PLOT6/4/2026 2:50 PM

NOTICE TO DRAWING HOLDER

WAGES CIVIL, LLC, HEREINAFTER REFERRED TO AS ENGINEER, HAS PREPARED & FURNISHED THIS DRAWING TO THE OWNER FOR USE ON THIS PROJECT ONLY. THIS DRAWING SHOULD NOT BE USED ON EXTENSIONS OF THIS PROJECT OR ON ANY OTHER PROJECT. ANY REUSE OF THIS DRAWING WITHOUT WRITTEN VERIFICATION OR ADAPTATION BY THE ENGINEER SHALL BE AT THE REUSER'S SOLE RISK AND THE REUSER SHALL INDEMNIFY & HOLD HARMLESS THE ENGINEER FROM ALL CLAIMS, DAMAGES, LOSSES & EXPENSES INCLUDING ATTORNEY'S FEES ARISING OUT OF OR RESULTING THEREFROM.

REVISIONS			DRAWING INFORMATION	
NO.	DATE	BY	DESCRIPTION	W-C PROJECT NO.: 121-001-25
				SCALE: AS NOTED
				SURVEYED BY: N/A
				DSGN: JW DATE: 5.8.2026
				DRWN: JW DATE: 5.8.2026
				CHKD: CW DATE: 5.8.2026

MMC TRAINING CENTER
MADISON COUNTY, MISSISSIPPI

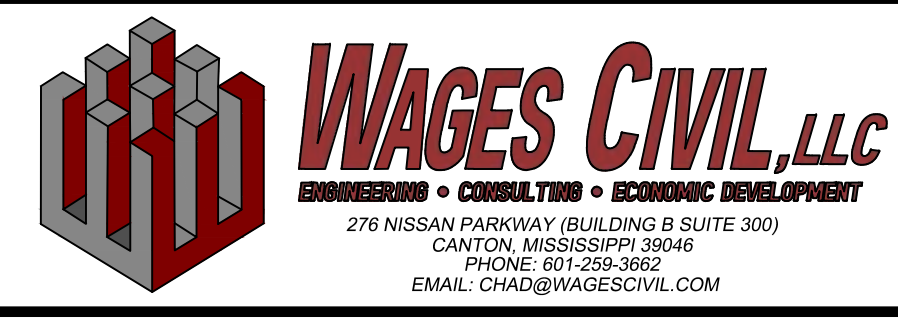

EXISTING CONDITIONS & AERIAL

PROJECT NUMBER:
121-001-25

DRAWING NUMBER:
C102

STAMP

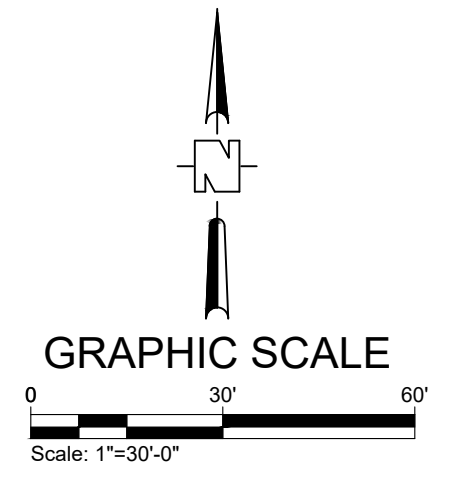
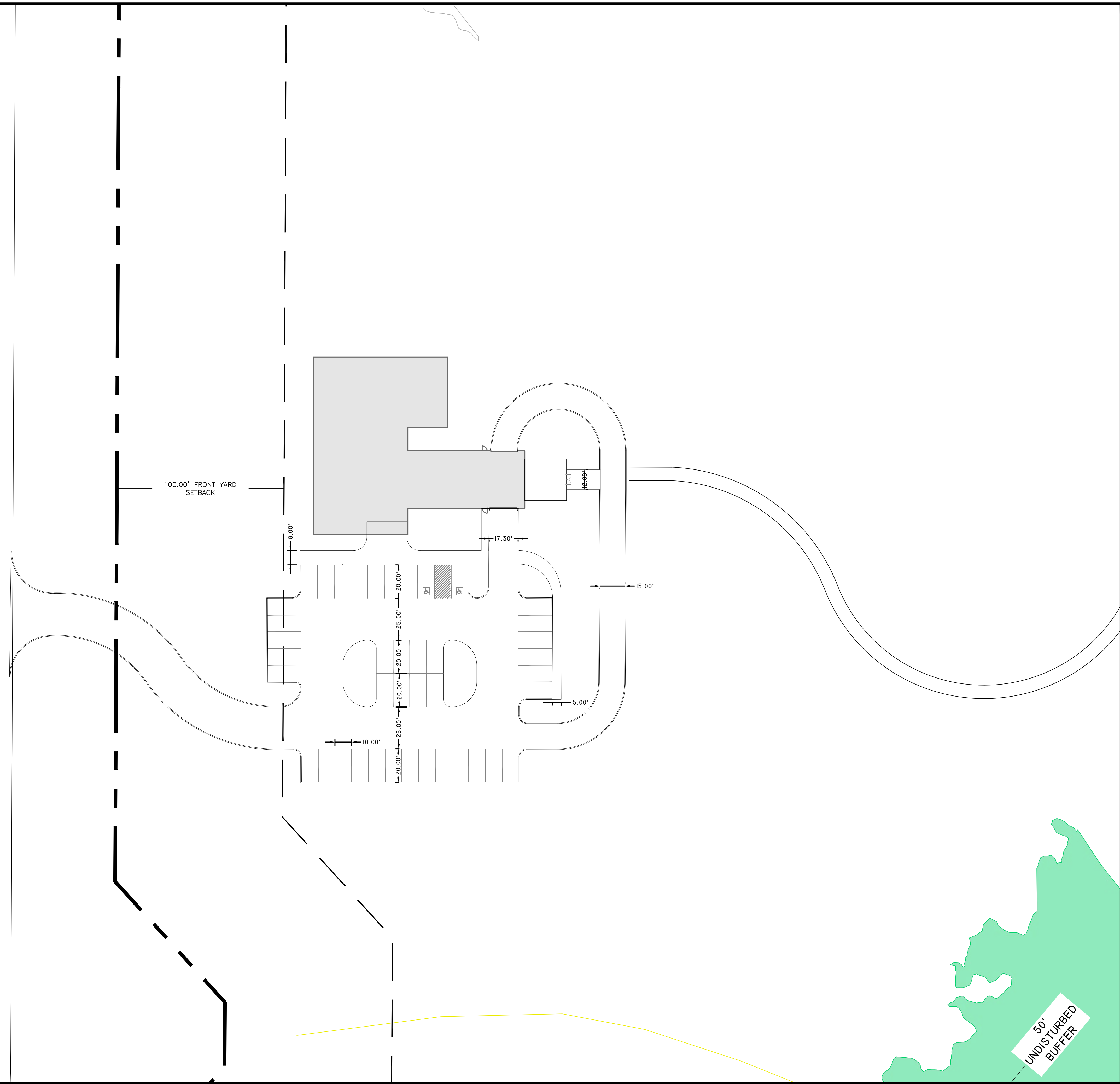

NOTICE TO DRAWING HOLDER

WAGES CIVIL, LLC, HERINAFTER REFERRED TO AS ENGINEER, HAS PREPARED & FURNISHED THIS DRAWING TO THE OWNER FOR USE ON THIS PROJECT ONLY. THIS DRAWING SHOULD NOT BE USED ON EXTENSIONS OF THIS PROJECT OR ON ANY OTHER PROJECT. ANY REUSE OF THIS DRAWING WITHOUT WRITTEN VERIFICATION OR ADAPTATION BY THE ENGINEER SHALL BE AT THE REUSER'S SOLE RISK AND THE REUSER SHALL INDEMNIFY & HOLD HARMLESS THE ENGINEER FROM ALL CLAIMS, DAMAGES, LOSSES & EXPENSES INCLUDING ATTORNEY'S FEES ARISING OUT OF OR RESULTING THEREFROM.

REVISIONS			DRAWING INFORMATION	
NO.	DATE	BY	DESCRIPTION	
				W-C PROJECT NO.: 121-001-25
				SCALE: AS NOTED
				SURVEYED BY: N/A
				DSGN: JW DATE: 5.8.2026
				DRWN: JW DATE: 5.8.2026
				CHKD: CW DATE: 5.8.2026

MMC TRAINING CENTER
MADISON COUNTY, MISSISSIPPI

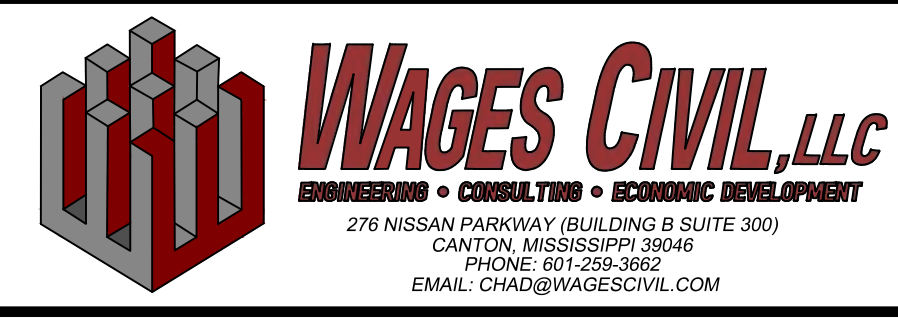

SITE PLAN

PROJECT NUMBER:
121-001-25

DRAWING NUMBER:
C104

STAMP

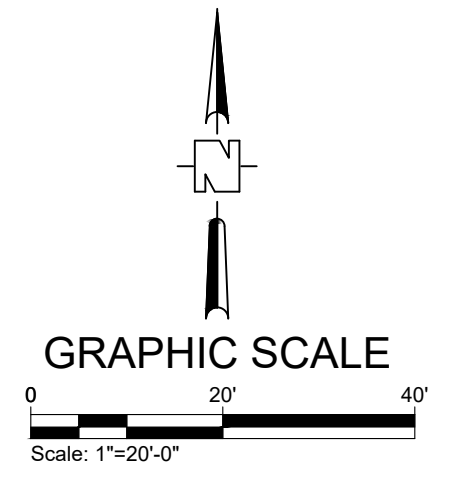

NOTICE TO DRAWING HOLDER

WAGES CIVIL, LLC, HERINAFTER REFERRED TO AS ENGINEER, HAS PREPARED & FURNISHED THIS DRAWING TO THE OWNER FOR USE ON THIS PROJECT ONLY. THIS DRAWING SHOULD NOT BE USED ON EXTENSIONS OF THIS PROJECT OR ON ANY OTHER PROJECT. ANY REUSE OF THIS DRAWING WITHOUT WRITTEN VERIFICATION OR ADAPTATION BY THE ENGINEER SHALL BE AT THE REUSER'S SOLE RISK AND THE REUSER SHALL INDEMNIFY & HOLD HARMLESS THE ENGINEER FROM ALL CLAIMS, DAMAGES, LOSSES & EXPENSES INCLUDING ATTORNEY'S FEES ARISING OUT OF OR RESULTING THEREFROM.

REVISIONS			DRAWING INFORMATION	
NO.	DATE	BY	DESCRIPTION	

W-C PROJECT NO.: 121-001-25
 SCALE: AS NOTED
 SURVEYED BY: N/A
 DSGN: JW DATE: 5.8.2026
 DRWN: JW DATE: 5.8.2026
 CHKD: CW DATE: 5.8.2026

MMC TRAINING CENTER
 MADISON COUNTY, MISSISSIPPI

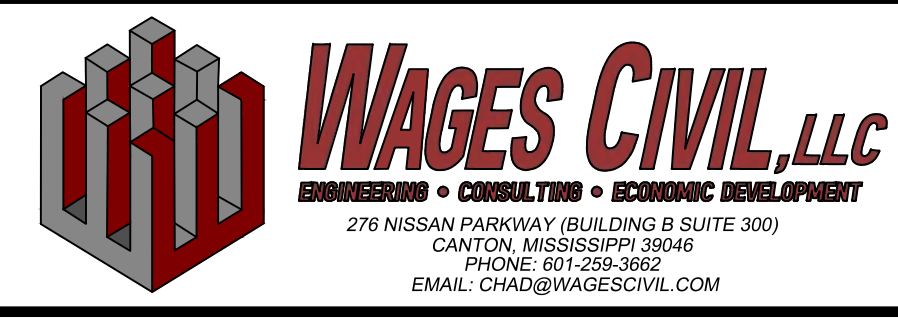

GRADING PLAN

PROJECT NUMBER:
 121-001-25

DRAWING NUMBER:
 C107

STAMP

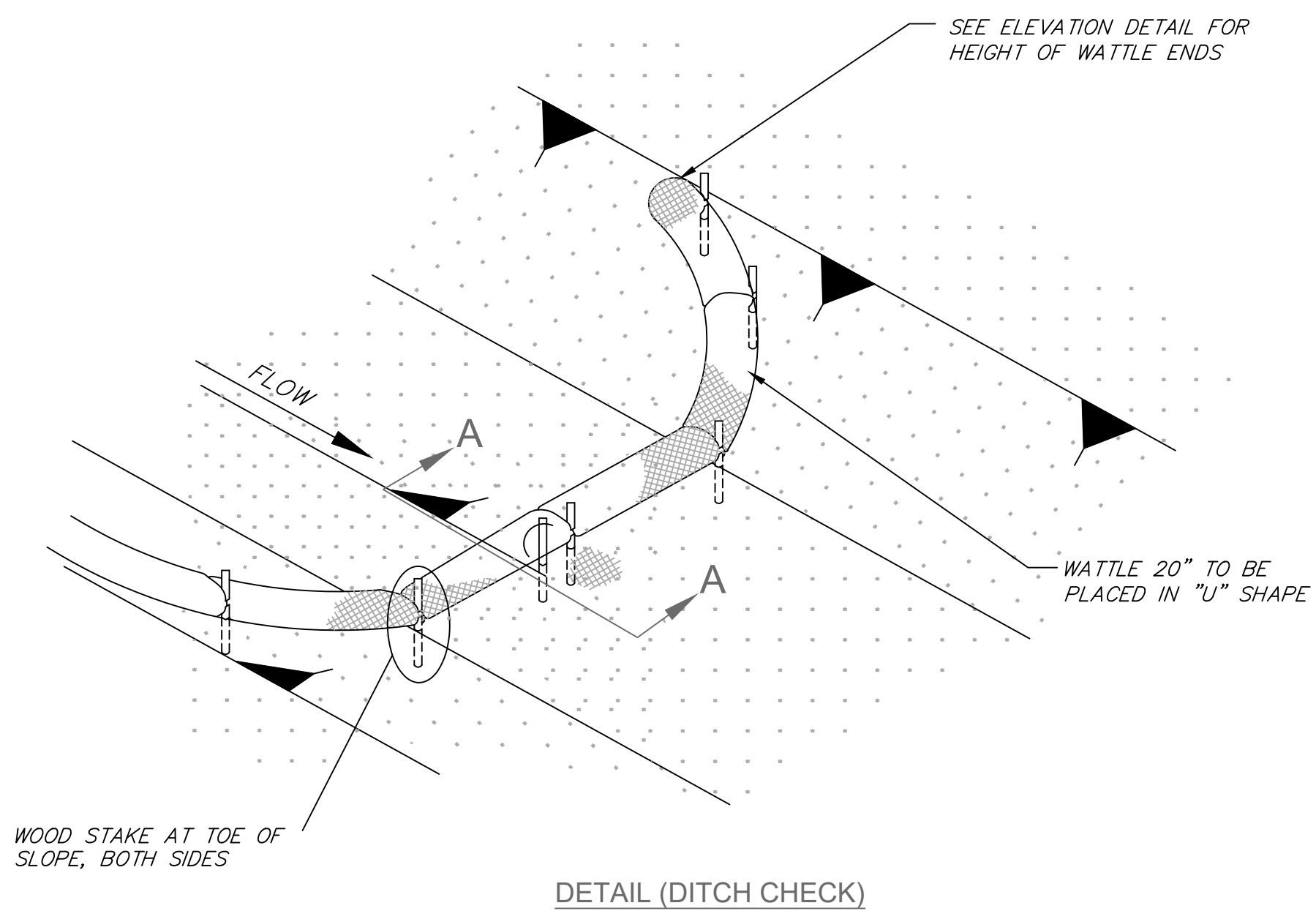

DETAIL (DITCH CHECK)

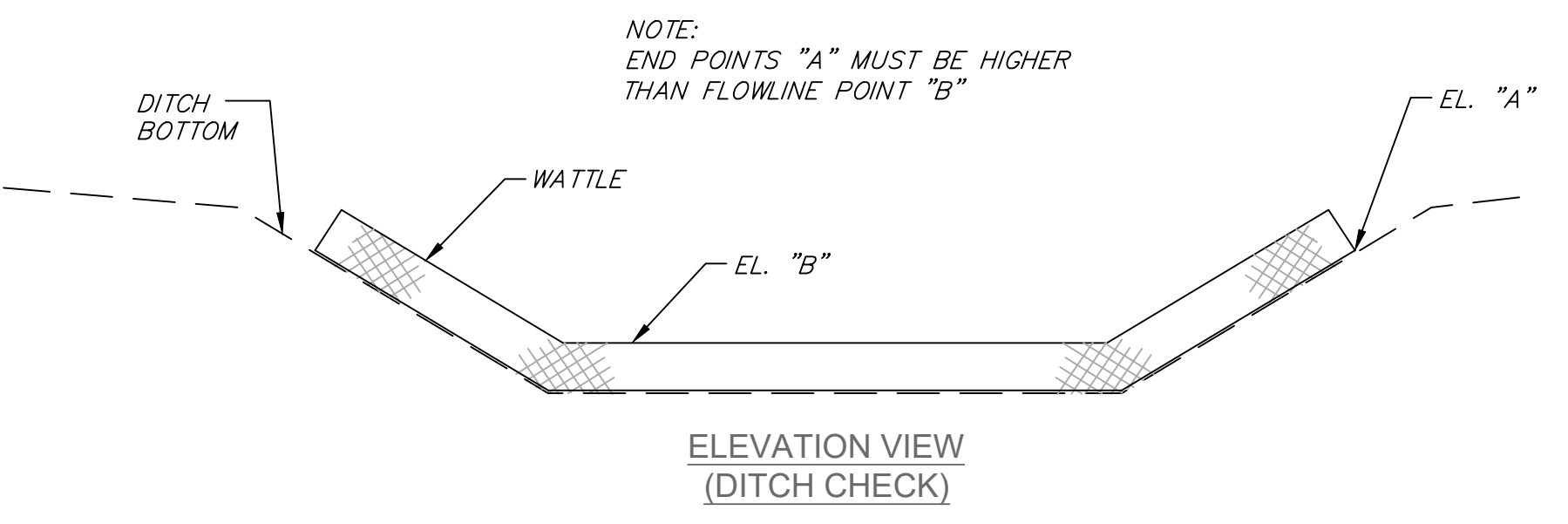

ELEVATION VIEW (DITCH CHECK)

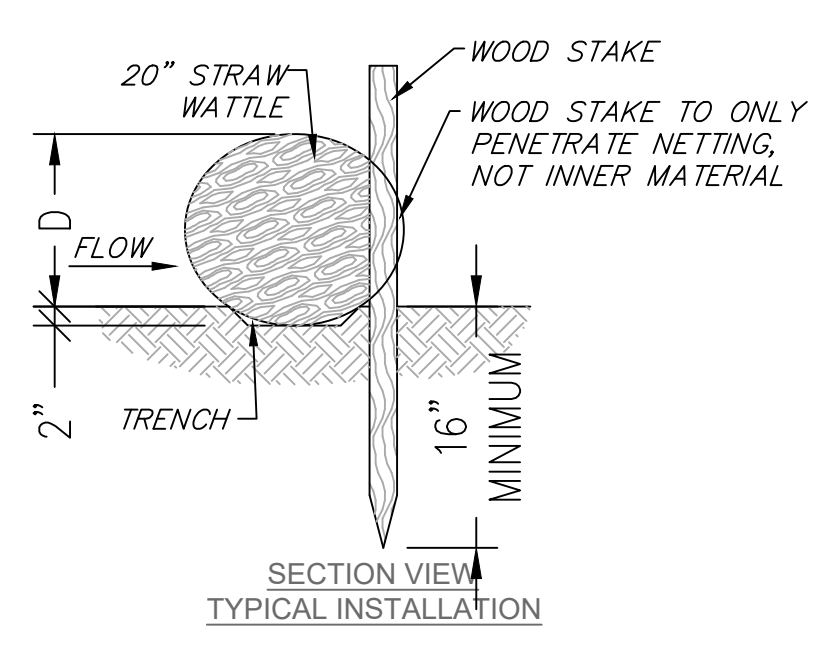

SECTION VIEW TYPICAL INSTALLATION

- NOTES:
1. MINIMUM RECOMMENDED PLACEMENT INTERVAL BETWEEN WATTLE DITCH CHECK IS 100' UNLESS SHOWN OTHERWISE ON THE PLANS OR EROSION CONTROL PLAN APPROVED BY THE ENGINEER.
 2. ANCHORING WOOD STAKES SHALL BE SIZED, SPACED, DRIVEN, AND BE OF A MATERIAL THAT EFFECTIVELY SECURES THE CHECK. STAKE SPACING SHALL BE A MAXIMUM OF THREE FEET. ALL NON-DEGRADABLE MATERIALS SHALL BE REMOVED WHEN NO LONGER NEEDED.
 3. WATTLES SHOULD NOT BE USED IN HARD BOTTOM CHANNELS.

WATTLE DITCH CHECK SELECTION GUIDELINES

WATTLE DITCH CHECKS ARE APPROPRIATE FOR VELOCITY REDUCTION AND CONTROL OF SEDIMENT TRANSPORT UNDER LOW TO MEDIUM FLOW CONDITIONS.

STRAW WATTLE INSTALLATION DETAIL
NOT TO SCALE

1 STRAW WATTLE INSTALLATION DETAIL
C-9 NOT TO SCALE

DEFINITION - A STONE STABILIZED PAD LOCATED AT POINTS OF VEHICULAR INGRESS AND EGRESS ON A CONSTRUCTION SITE.

PURPOSE - TO REDUCE THE AMOUNT OF MUD TRANSPORTED ONTO PUBLIC ROADS BY MOTOR VEHICLES OR RUNOFF.

CONDITIONS WHERE PRACTICE APPLIES - WHEREVER TRAFFIC WILL BE LEAVING A CONSTRUCTION SITE AND MOVE DIRECTLY ONTO A PUBLIC ROAD OR OTHER PAVED AREA.

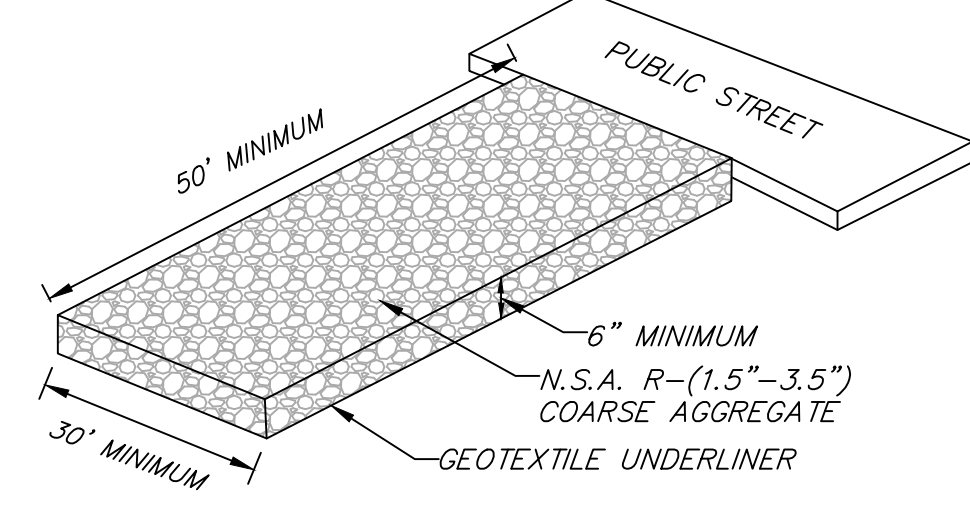

MAINTENANCE - THE ENTRANCE SHALL BE MAINTAINED IN A CONDITION WHICH WILL PREVENT TRACKING OR FLOW OF MUD ONTO PUBLIC RIGHTS-OF-WAY. THIS MAY REQUIRE PERIODIC TOP DRESSING WITH 2 INCH STONE, AS CONDITIONS DEMAND, AND REPAIR AND/OR CLEANEST OF ANY STRUCTURES USED TO TRAP SEDIMENT. ALL MATERIALS SPILLED, DROPPED, WASHED, OR TRACKED FROM VEHICLES ONTO ROADWAYS OR INTO STORM DRAINS MUST BE REMOVED IMMEDIATELY.

2 CONSTRUCTION EGRESS
C-9 NOT TO SCALE

PLANNING CONSIDERATIONS - GENERAL CRITERIA REQUIRES THAT ROADS ADJACENT TO A CONSTRUCTION SITE SHALL BE CLEAN AT THE END OF EACH DAY. CONSTRUCTION ENTRANCES PROVIDE AN AREA WHERE MUD CAN BE REMOVED FROM CONSTRUCTION VEHICLE TIRES BEFORE THEY ENTER A PUBLIC ROAD. IF THE ACTION OF VEHICLE TRAVELING OVER THE GRAVEL PAD IS NOT SUFFICIENT TO REMOVE THE MAJORITY OF THE MUD, THEN THE TIRES MUST BE WASHED BEFORE THE VEHICLE ENTERS A PUBLIC ROAD. IF WASHING IS USED, PROVISIONS MUST BE MADE TO INTERCEPT THE WASH WATER AND TRAP THE SEDIMENT BEFORE IT IS CARRIED OFF-SITE. CONSTRUCTION ENTRANCES SHOULD BE USED IN CONJUNCTION WITH THE STABILIZATION OF CONSTRUCTION ROADS TO REDUCE THE AMOUNT OF MUD PICKED UP BY CONSTRUCTION VEHICLES.

- DESIGN CRITERIA**
1. AGGREGATE SIZE- MDOT AGGREGATE (2-3 INCH STONE) SHOULD BE USED.
 2. ENTRANCE DIMENSIONS- THE AGGREGATE LAYER MUST BE AT LEAST 6 INCHES THICK. IT MUST EXTEND THE FULL WIDTH OF THE VEHICULAR INGRESS AND EGRESS AREA. THE LENGTH OF THE ENTRANCE MUST BE AT LEAST 50 FEET.
 3. WASHING- IF CONDITIONS ON THE SITE ARE SUCH THAT THE MAJORITY OF THE MUD IS NOT REMOVED BY THE VEHICLES TRAVELING OVER THE GRAVEL, THEN THE TIRES OF THE VEHICLES MUST BE WASHED BEFORE ENTERING A PUBLIC ROAD. WASH WATER MUST BE CARRIED AWAY FROM THE ENTRANCE TO A SETTLING AREA TO REMOVE SEDIMENT. A WASH RACK MAY ALSO BE USED TO MAKE WASHING MORE CONVENIENT AND EFFECTIVE.
 4. LOCATION- THE ENTRANCE SHOULD BE LOCATED TO PROVIDE FOR MAXIMUM UTILITY BY ALL CONSTRUCTION VEHICLES.

CONSTRUCTION SPECIFICATIONS - THE AREA OF THE ENTRANCE SHOULD BE CLEARED OF ALL VEGETATION, ROOTS, AND OTHER OBJECTIONABLE MATERIAL. THE GRAVEL SHALL BE PLACED TO THE SPECIFIED DIMENSIONS. ANY DRAINAGE FACILITIES REQUIRED BECAUSE OF WASHING SHOULD BE CONSTRUCTED ACCORDING TO SPECIFICATIONS. IF WASH RACKS ARE USED, THEY SHOULD BE INSTALLED ACCORDING TO MANUFACTURER'S SPECIFICATIONS.

NOTE:
DIRT CORE ALLOWABLE AS WELL AS OTHER MEANS TO SEAL DAM WHEN FINES ARE NOT AVAILABLE TO CHOKE STONE.

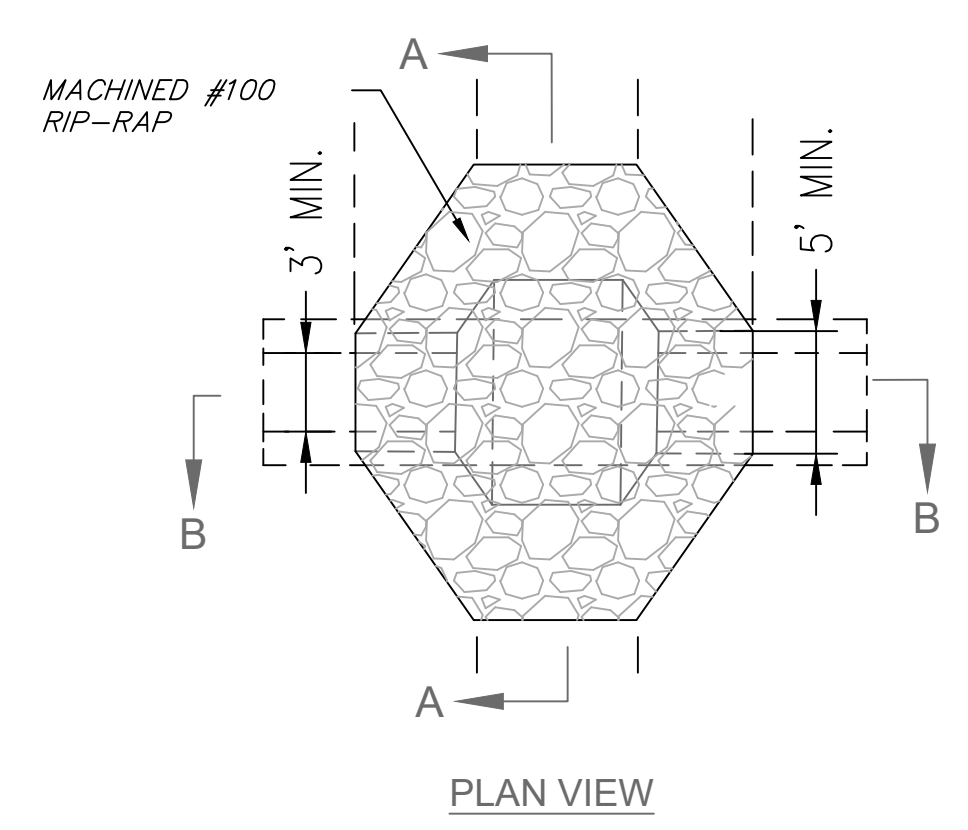

PLAN VIEW

EROSION CONTROL PLAN LEGEND:
(STONE CHECK DAM)

3 STONE CHECK DAM
C-9 NOT TO SCALE

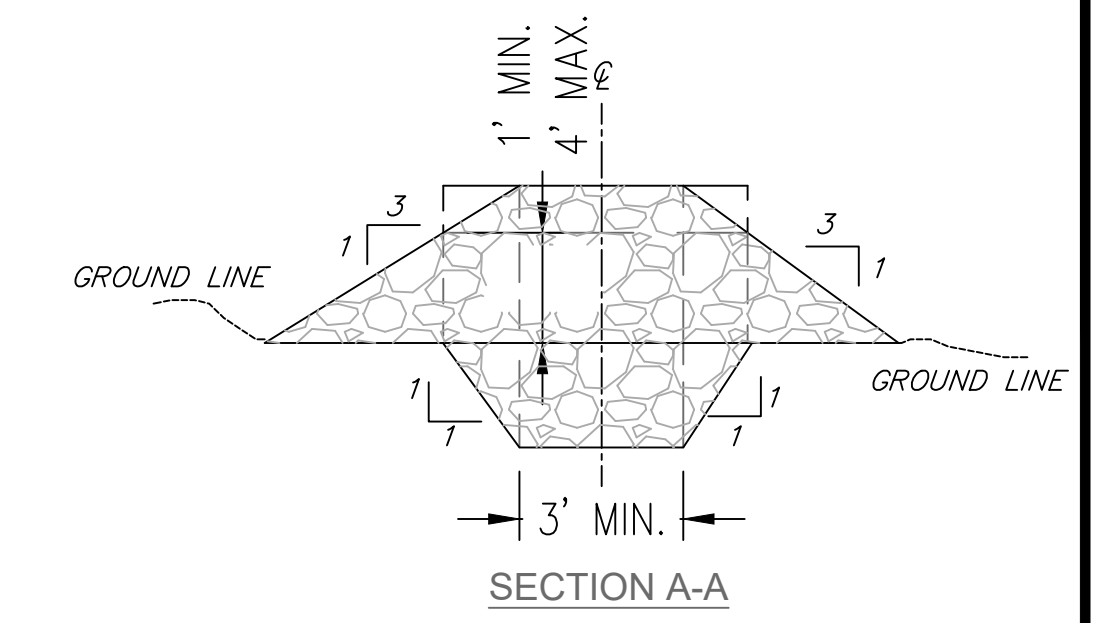

SECTION A-A

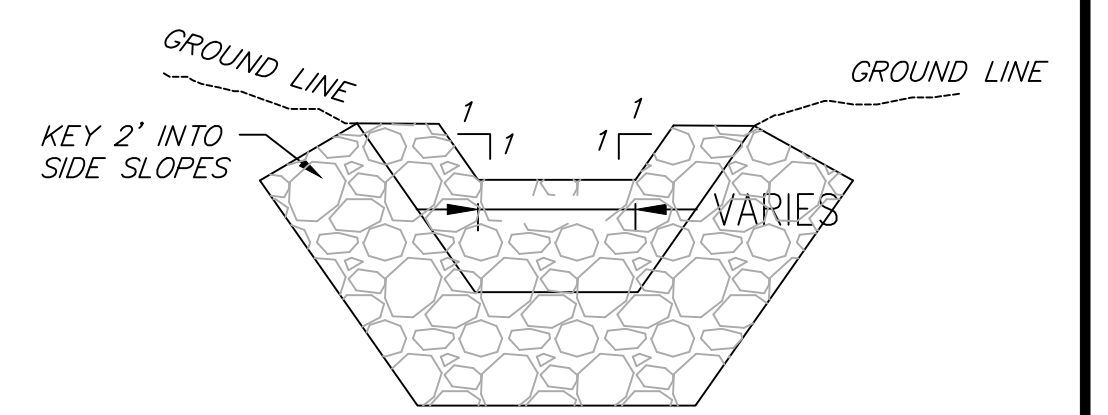

SECTION B-B
UPSTREAM ELEVATION

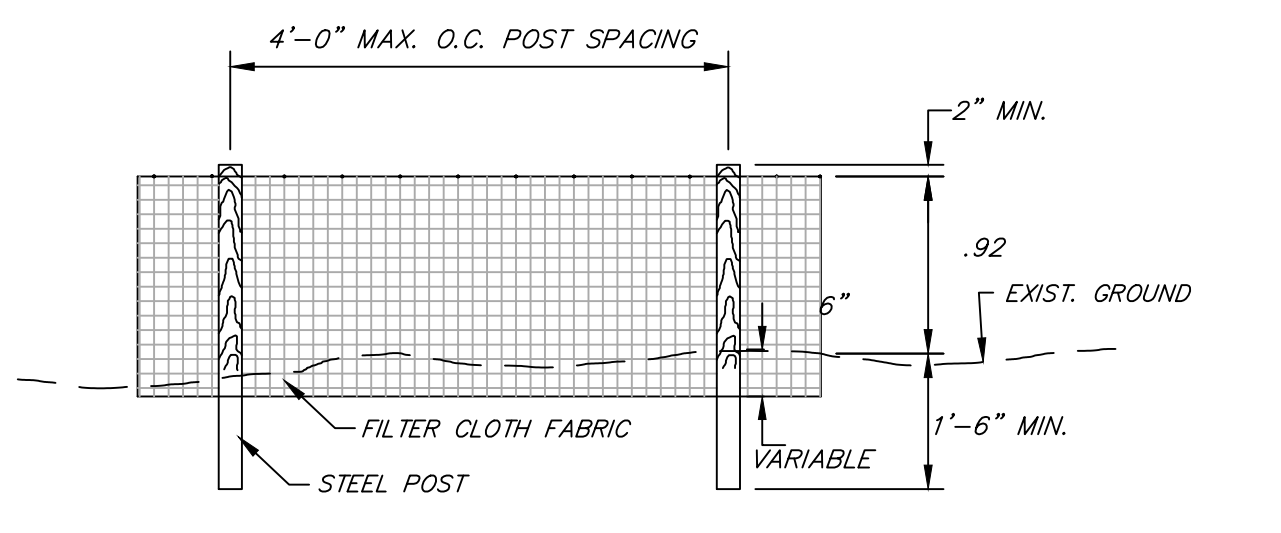

ELEVATION

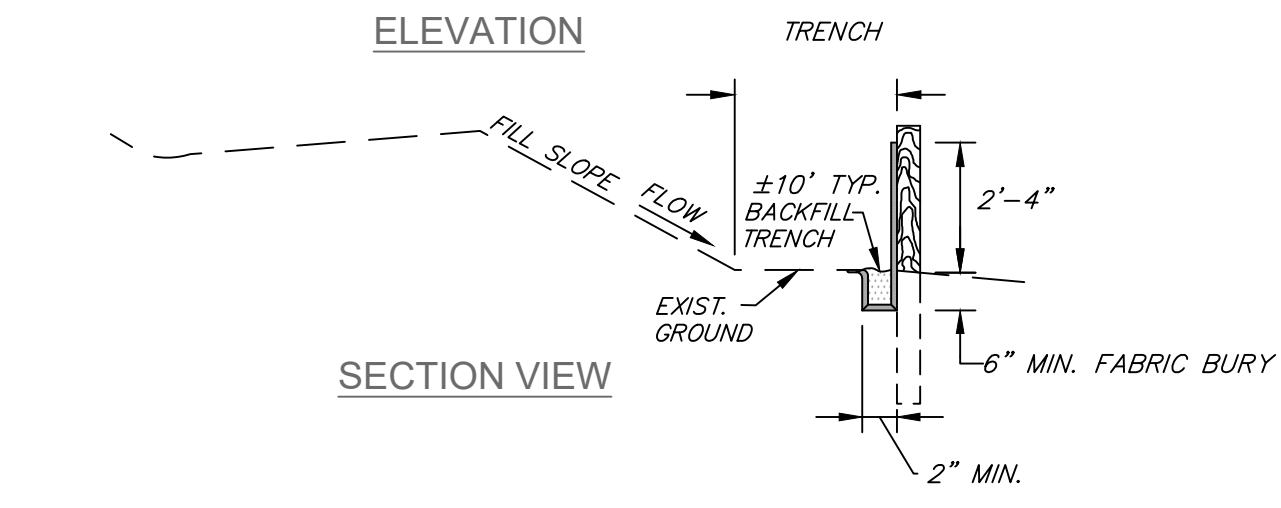

SECTION VIEW

4 TEMPORARY SILT FENCE
C-9 NOT TO SCALE

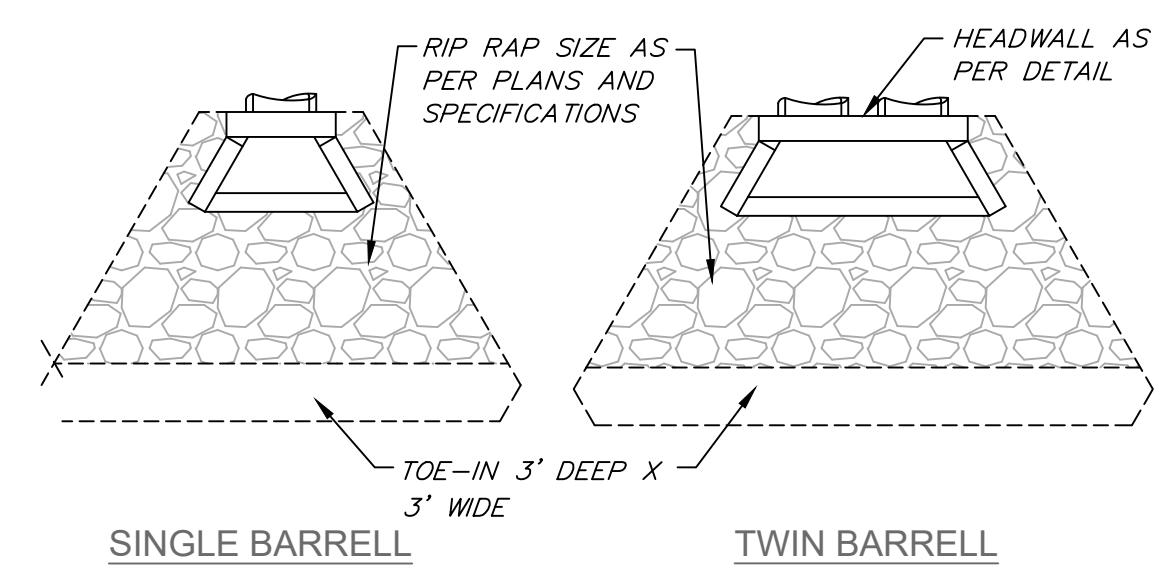

SINGLE BARRELL

TWIN BARRELL

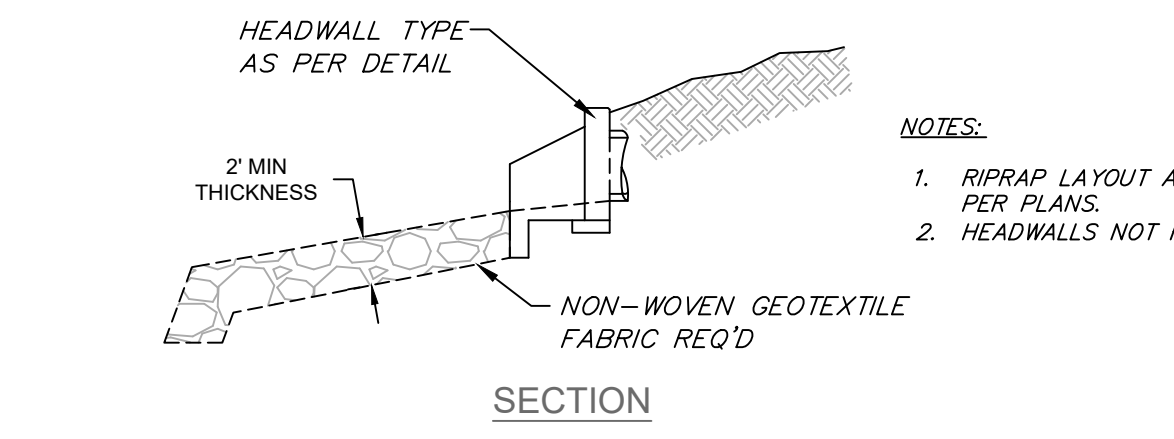

SECTION

- NOTES:
1. RIPRAP LAYOUT AND DIMENSIONS PER PLANS.
 2. HEADWALLS NOT REQ'D.

5 RIP RAP PLACEMENT
C-9 NOT TO SCALE

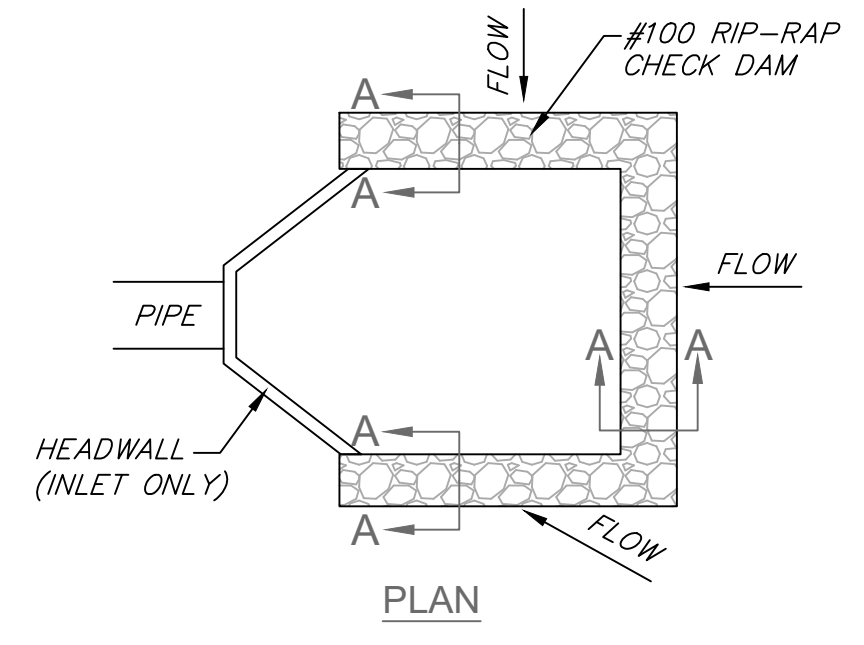

PLAN

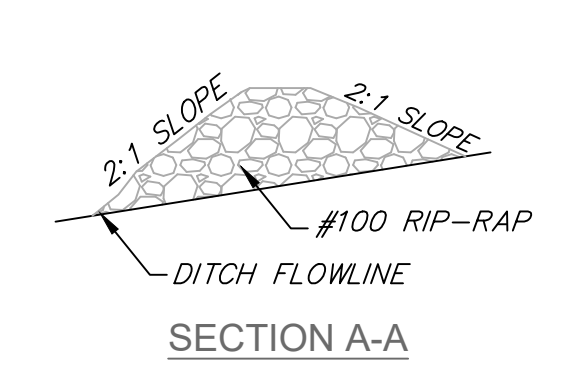

SECTION A-A

6 STONE CHECK DAM AT PIPE INLETS
C-9 NOT TO SCALE

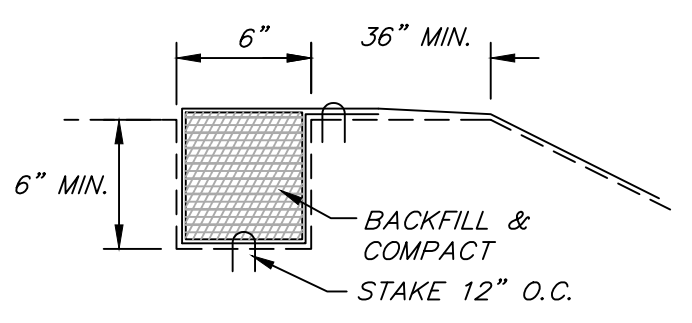

DETAIL OF TOP TRENCH

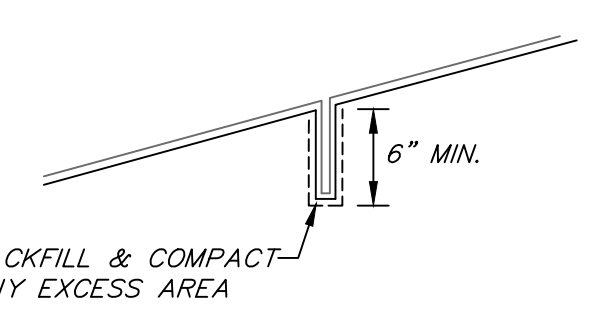

DETAIL OF INTERMEDIATE TRENCH

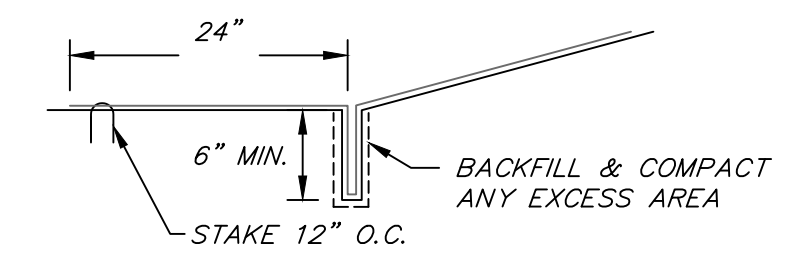

DETAIL OF BOTTOM TRENCH

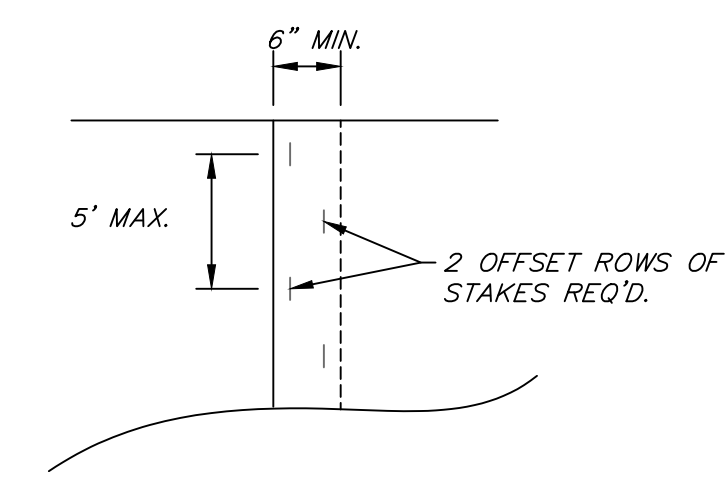

DETAIL OF LONGITUDINAL OVERLAP

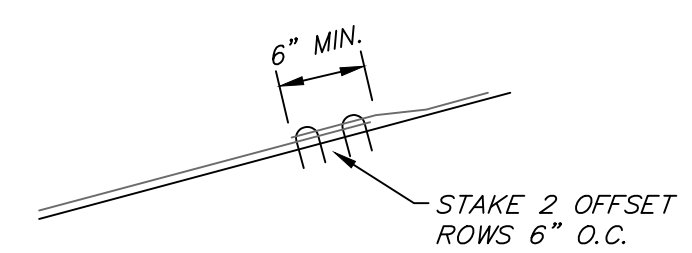

DETAIL OF TRANSVERSE OVERLAP

7 EROSION CONTROL BLANKET
C-9 NOT TO SCALE

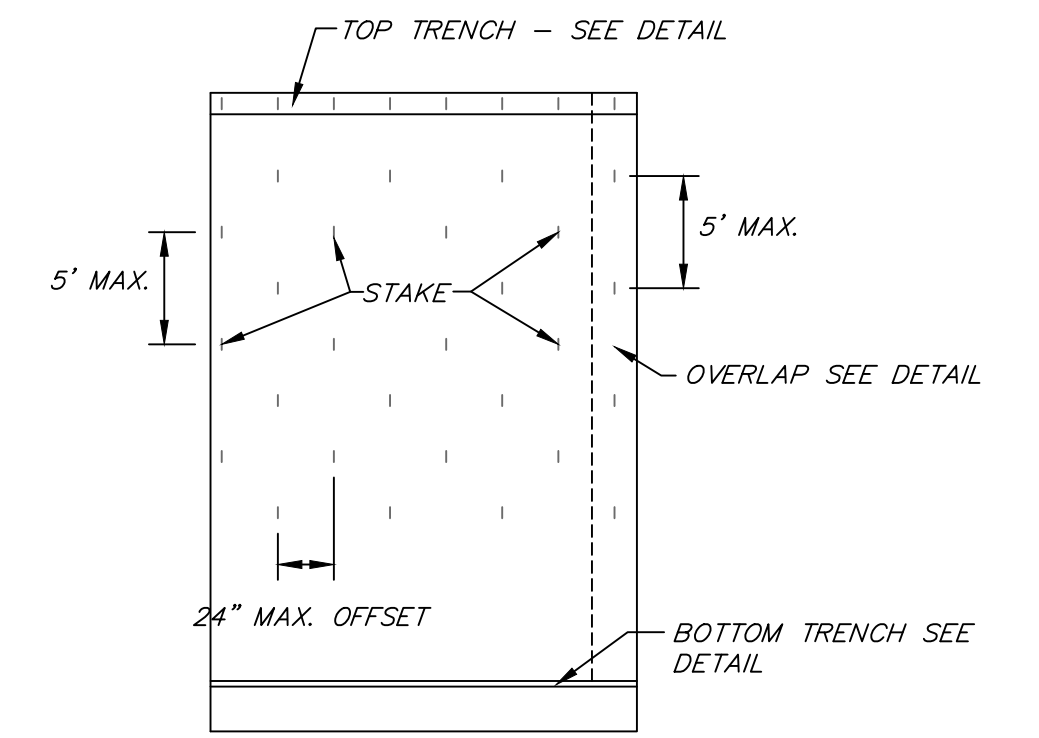

DETAIL OF EROSION CONTROL BLANKET

NOTICE TO DRAWING HOLDER				REVISIONS		DRAWING INFORMATION	
WAGES CIVIL, LLC, HERINAFTER REFERRED TO AS ENGINEER, HAS PREPARED & FURNISHED THIS DRAWING TO THE OWNER FOR USE ON THIS PROJECT ONLY. THIS DRAWING SHOULD NOT BE USED ON EXTENSIONS OF THIS PROJECT OR ON ANY OTHER PROJECT. ANY REUSE OF THIS DRAWING WITHOUT WRITTEN VERIFICATION OR ADAPTATION BY THE ENGINEER SHALL BE AT THE REUSER'S SOLE RISK AND THE REUSER SHALL INDEMNIFY & HOLD HARMLESS THE ENGINEER FROM ALL CLAIMS, DAMAGES, LOSSES & EXPENSES INCLUDING ATTORNEY'S FEES ARISING OUT OF OR RESULTING THEREFROM.				NO.	DATE	BY	DESCRIPTION
				W-C PROJECT NO.: 121-001-25		SCALE: AS NOTED	
				SURVEYED BY: N/A		DSGN: JW DATE: 5.8.2026	
				DRWN: JW DATE: 5.8.2026		CHKD: CW DATE: 5.8.2026	

MMC TRAINING CENTER
MADISON COUNTY, MISSISSIPPI



DETAILS	
PROJECT NUMBER: 121-001-25	DRAWING NUMBER: C201

STAMP

PRELIMINARY CONSTRUCTION PLANS

MMC TRAINING CENTER

C:\Users\ZachByrd\OneDrive\Documents\Projects\MMC Training Center\Project Files\Civil\CAD\Sheet_8-DETAILS.dwg SAVE:5/7/2026 3:40 PM PLOT:6/4/2026 2:50 PM

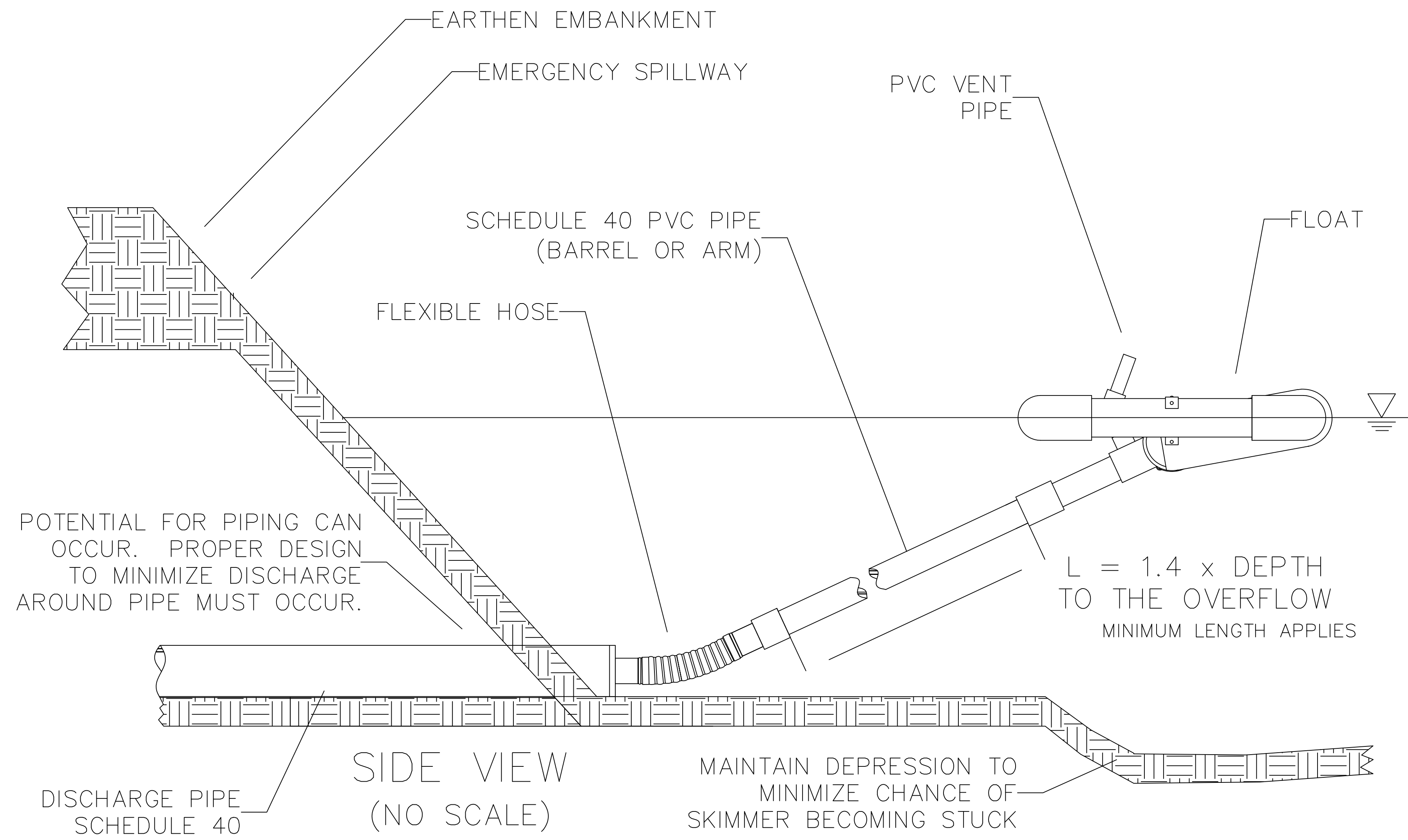
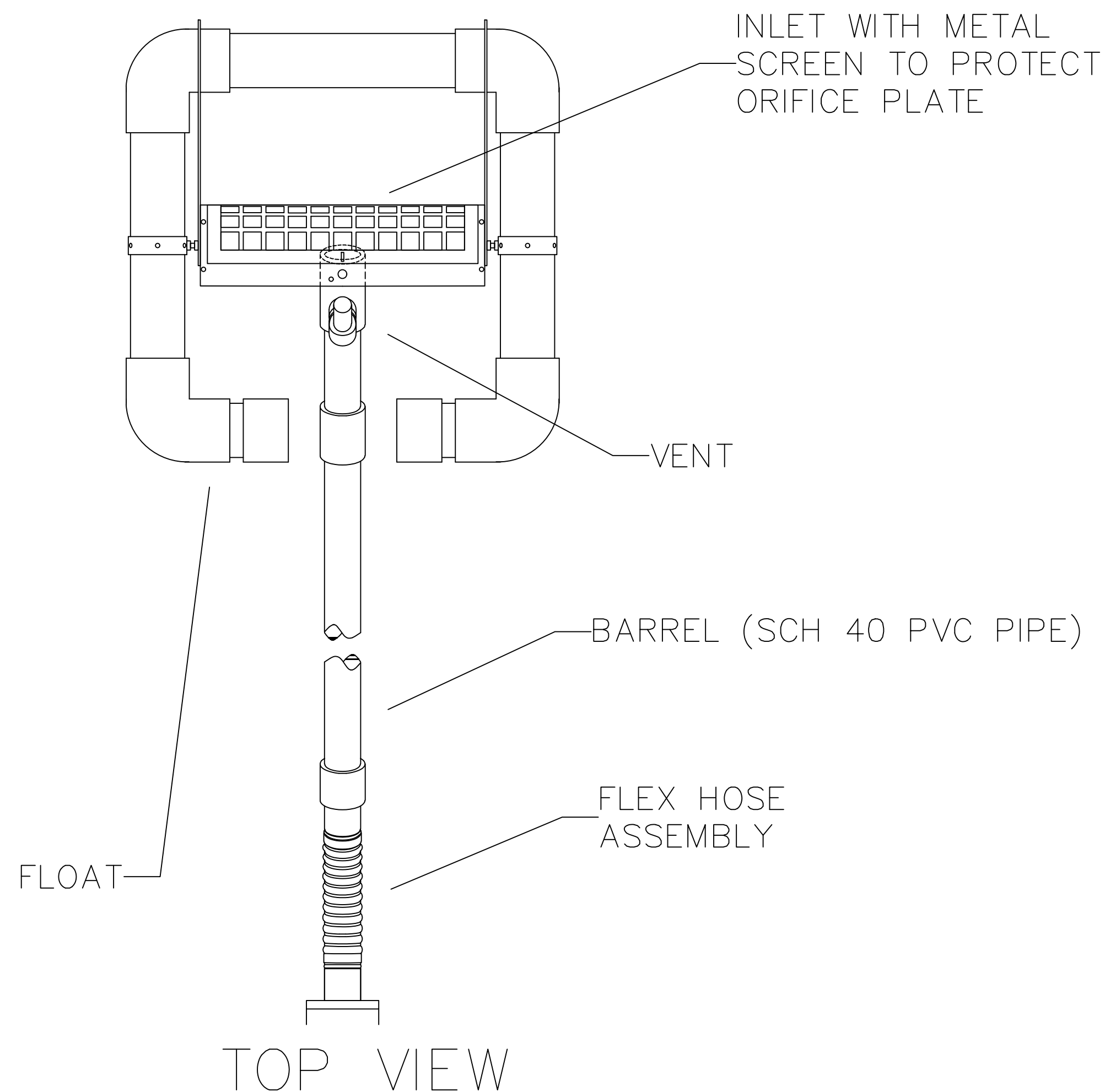

GENERAL NOTES:

1. FAIRCLOTH SKIMMER® FLOW RATES WERE USED AS THE BASIS OF DESIGN WHEN DETERMINING DRAINAGE CALCULATIONS. UTILIZING A PRODUCT FROM AN ALTERNATIVE MANUFACTURER WILL CREATE A SIGNIFICANT DEVIATION TO THE DESIGN AND MUST BE APPROVED AND RECALCULATED BY THE DESIGN ENGINEER.
2. PROPER ORIFICE OPENING MUST BE SELECTED TO ENSURE POND DRAINS IN CORRECT AMOUNT OF TIME. MODIFICATIONS MAY BE REQUIRED IF FIELD CONDITIONS WARRANT A CHANGE.
3. BARREL PIPE SHOULD BE 1.4 X DEPTH OF THE BASIN TO ENSURE PROPER FUNCTION.

DRAWN BY T. R. EVANS 08/24

FAIRCLOTH SKIMMER® DISCHARGE SYSTEM WITH EMBANKMENT

FAIRCLOTH SKIMMER
 WWW.FAIRCLOTHSKIMMER.COM
 TELEPHONE: (919) 732-1244
 FAX: (919) 732-1266
 EMAIL: SALES@FAIRCLOTHSKIMMER.COM

C:\Users\zooibye\OneDrive\Documents\Wages Civil\WCI21-001-25 MMC Training Center\Project Files\Civil\CAD\SHEET_8-DETAILS.dwg SAVE:5/7/2026 3:40 PM PLOT:6/4/2026 2:50 PM

NOTICE TO DRAWING HOLDER
 WAGES CIVIL, LLC, HERINAFTER REFERRED TO AS ENGINEER, HAS PREPARED & FURNISHED THIS DRAWING TO THE OWNER FOR USE ON THIS PROJECT ONLY. THIS DRAWING SHOULD NOT BE USED ON EXTENSIONS OF THIS PROJECT OR ON ANY OTHER PROJECT. ANY REUSE OF THIS DRAWING WITHOUT WRITTEN VERIFICATION OR ADAPTATION BY THE ENGINEER SHALL BE AT THE REUSER'S SOLE RISK AND THE REUSER SHALL INDEMNIFY & HOLD HARMLESS THE ENGINEER FROM ALL CLAIMS, DAMAGES, LOSSES & EXPENSES INCLUDING ATTORNEY'S FEES ARISING OUT OF OR RESULTING THEREFROM.

REVISIONS				DRAWING INFORMATION	
NO.	DATE	BY	DESCRIPTION	W-C PROJECT NO.:	SCALE:
				121-001-25	AS NOTED
					SURVEYED BY: N/A
					DSGN: JW DATE: 5.8.2026
					DRWN: JW DATE: 5.8.2026
					CHKD: CW DATE: 5.8.2026

MMC TRAINING CENTER
 MADISON COUNTY, MISSISSIPPI



DETAILS	
PROJECT NUMBER: 121-001-25	DRAWING NUMBER: C202

STAMP